

UNPACKING

ASSEMBLY MANUAL



SCAN ME

TO WATCH THE VIDEO



SCAN ME

TO WATCH THE VIDEO

GTT5010

GRAIN BAGGER



USER'S MANUAL

OPERATION, MAINTENANCE
AND SPARE PARTS

INDEX



SAFETY

- 3.a. Attitude Toward Safety
- 3.b. "ATTENTION" Symbol and Signal Words
- 3.c. Personal Protective Equipment
- 3.d. Safety Warnings
- 3.e. Risk Analysis



RECEIVING THE MACHINE

- 4.a. Identification of your grain bagger
- 4.b. Contact Information



PREPARATION AND SETUP

- 4.c. Operation Principles
- 5.a. Recommendations to Ease Subsequent Extraction
- 5.b. Prior Checks In the Field
- 5.c. Prior Checks on the Machine
- 5.d. Machine Parking
- 5.e. Machine Positioning
- 5.f. Adjusting the brake system
- 5.g. Grain bag Preparation and Mounting
- 5.h. Adjustments Before Starting the Bagging



BAGGING PROCEDURE

- 6.a. Operation Start-up
- 6.b. Operation Parameters
- 6.c. Protection against Overloads
- 6.d. Interruptions During Bagging
- 6.e. Operation at the End of the Grain Bag
- 6.f. Closing the Grain Bag



MAINTENANCE

- 7.a. Maintenance Schedule
- 7.b. Maintenance after Receiving the Machine
- 7.c. Lubrication
- 7.d. Replacement of Parts Subject to Wear
- 7.e. Brake Fluid
- 7.f. Wear Prevention on Flexible Pipes
- 7.g. Tire Change



SPECIFICATIONS



GUARANTEE TERMS



PARTS SUBJECT TO NORMAL WEAR AND TEAR



OPCIONALES



QUICK GUIDE

GTT5010 BAGGER OPERATION



BAGGING PROCESS / START OF OPERATION:



- 1 Connect the bagger towbar (A) to the tow tractor.

- 2 To adjust the height of the tiller to that of the tractor hitch, first activate the command valve, then adjust the height through the indicated spool and finally close the command valve.



- 2 Hook up the hydraulic pan hoses (C).



- 3 Stop the tractor and couple the cardan shaft (D).



- 5 Use the rear hydraulic foot to leave the machine parked without the bag. Use the front jack in case of removing the tractor.
- 6 If the machine needs to be transported, make sure the brake is disengaged.



EASY LIFT / PAN

En caso de portar bandeja, easy lift o lanza hidráulica, primero abrir el paso a través de las válvulas de comando y accionar con el spool correspondiente.

WARNING: Failure to close the valves may cause hydraulic cylinders to open while bagging, and thus the position of some assemblies could be modified.

GRAIN BAG PREPARATION AND SET UP



- 1 Put the grain bag on the cradle, centring it with the mark stamped in the bag by the manufacturer.
- 2 Operate the easy lift command to lift the bag. When it makes contact with the tunnel, the operator will need to accommodate the bag on both sides of the machine.

3

At the same time the grain bag embraces the tunnel, its bottom part should be held by the pan.

Operate the pan hydraulic cylinder (the space between the hydraulic pan and the tunnel bottom is pre-set from factory), put the rubber flap in place and remember to put back the pin that connects the pan with the chassis.



Check our website for further information on the schedule of MANUALS AND SPARE PARTS:

<https://akrongrainbagging.com/>

You can also find a QR code (and a password) to access our website, in your AKRON machine.

SAFETY

Safety aspects for the operator, for third parties and neighboring property before the operation of the machine.



3-A. ATTITUDE TOWARD SAFETY

What is most important for preventing accidents of any kind is

- Positive attitude · As well as observing the manufacturer's recommendations
- The habit must be developed of foreseeing and analyzing every possible contingency.

3-B. "ATTENTION" SYMBOL AND SIGNAL WORDS

Throughout the present manual, the "Attention" symbol is used to indicate risk situations for the operator, the machine, other equipment or other people.

This symbol will appear together with certain signal words depending on the relative seriousness of each risk situation.



DANGER

100%

This identifies an imminent hazardous situation.



WARNING

60%

This identifies a potential hazardous situation.



IMPORTANT

30%

This describes a particular situation where the machine could be damaged or its normal operation could be affected.



3-C. PERSONAL PROTECTIVE EQUIPMENT

Akron S.A. recommends the use of the following personal protection items to prevent possible injury.

Tractor Driver	Machine operator
	1
2	2
3	3

3-D. . SAFETY WARNINGS

On different parts of the machine and on its accessories you will find decals with accident prevention symbols which must be considered as part and extension of the instructions detailed in this manual.

Special care must be taken to ensure these decals are present and legible during the entire working life of the machine.

If for any reason any of these gets lost or becomes illegible through wear, it is important to replace it immediately, indicating its corresponding code. To ask for a replacement decal, please contact either the manufacturer using the information given in 4-b "Contact information", or your local Technical Representative.

3-E. RISK ANALYSIS

The risk situations that typically arise during the operation of this machine are detailed below.

Recommendations are made that are of vital importance for the safety of the machine operators, of other workers nearby, and the machine itself.

The pictograms used are taken from IRAM standard 8075 "Tractors, agricultural and forestry and green space maintenance machinery - Safety signs and hazard pictograms - General principles and features". For more details, their location on the machine is shown in the following picture.

DECALS

98.682.106135



98.682.114122



98.682.114112



98.682.114152



98.470.114290



98.682.114128



98.682.114162



98.682.114187



98.682.114132



98.682.114158



98.682.126750



98.682.126226



98.682.126315

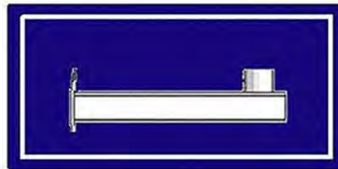

98.682.182120



98.682.114186



98.682.125118



98.682.126223



RECEIVING THE MACHINE



The **AKRON® GTT 5010** grain bagger is delivered almost ready for operation. Only a number of checks about issues related to transport must be made upon receiving the machine:

- 1 If the machine is delivered on a truck or similar vehicle, check that all the slings and elements used to fix the machine to the transport are removed.
- 2 Check that the tire pressure is at the values recommended in section 7 "Maintenance".
- 3 Check that all the main machine components are present and in good condition. The spare parts list included at the end of this manual makes a good checklist.
- 4 All the safety guards and protections should be present and in good condition (e.g., the transmission cover on the tractor side, the driveshaft cover, etc.).

4-A. IDENTIFICATION OF YOUR GRAIN BAGGER

When ordering replacement parts or requesting technical assistance or information, always provide the following details for product identification purposes:

- Model
- Mass (kg)
- Serial #

This information is engraved on the identification plate located on the wheel chassis.



4-B. CONTACT INFORMATION

AKRON S.A.

Rosario de Santa Fe 2256
X2400EFN - San Francisco (Córdoba)
ARGENTINA

CONTACT US : 0800 333 8300

SALES: +54 9 3564 435900 / ventas@akron.com.ar

SPARE PARTS: +54 9 03564 436777 - +54 9 3564 572816 - repuestos@akron.com.ar

TECHNICAL ASSISTANCE: +54 9 3564 572642 - serviciotecnico@akron.com.ar

ADMINISTRATION: +54 9 3564 330120 - admi@akron.com.ar



BAGGING PROCEDURE



6-A. OPERATION START-UP

With the machine and grain bag prepared as explained in the previous section, the bagging operation can be started following these steps:

- 1 Prepare the vehicle that will supply the grain to be bagged



- 1.a The grain entering the bagging machine should fall as directly as possible into the centre of the receiving hopper.



- 2 Use a straight line as a reference along the route of the grain bag in order to avoid bends in its entire length.

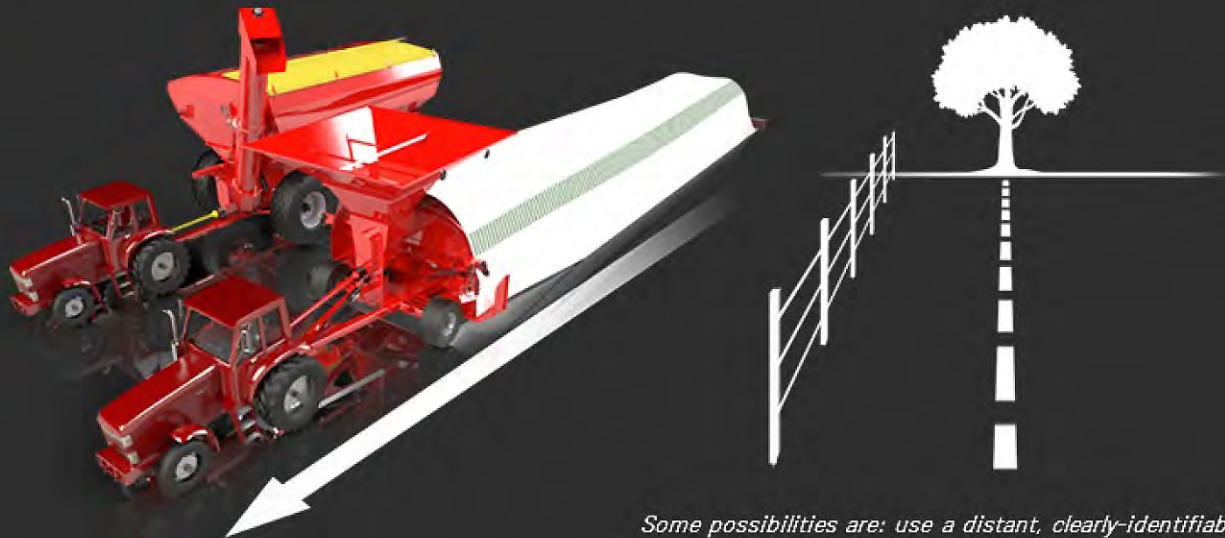

Some possibilities are: use a distant, clearly-identifiable tree as a reference; lay a string tensed along the route; keep a constant distance from a wire fence.

- 3 Remember that both tires should be inflated to a pressure within the range recommended in paragraph 7 Maintenance



- 4 Check that the initial pressure of the hydraulic brake system is set to 40/50 BAR (550 to 700 PSI). Then, adjust brake pressure until desired bag stretch is achieved.

IMPORTANT: Always start up the **PTO** before beginning to introduce grain into the hopper in order to avoid over-loading the auger

WARNING: When grain enters the receiving hopper and the grain bag end starts to become stressed, the bagging machine and the tractor will suddenly start to move.

The operators must be ready for this moment.

- 5 Gradually operate the tractor **PTO** until it reaches its running speed, **540 RPM**.



- 6 Start feeding grain gradually, checking that the end of the grain bag is adequately filled and is lying evenly on the ground as shown in Figure. Remember that the front end of the grain bag must be turned over.

Stop feeding grain as often as necessary in order to rearrange the end of the grain bag; it will be impossible to correct its position once it is fully loaded.

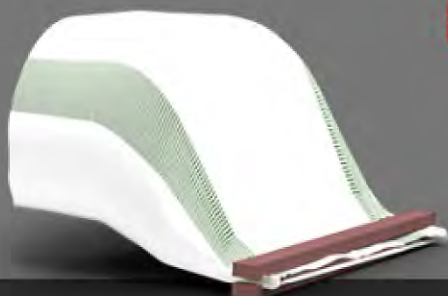

6-B. OPERATION PARAMETERS

- 1 The machine's braking force is directly related to the resulting tension in the silo bag; the pressure on the brakes should be adjusted (**approximately 80 bar**) so as to make the best use of the silo bag's storage capacity, i.e. to apply the greatest possible tension to the silo bag material according to the manufacturer's provisions. As shown in Figure , most silo bags have some kind of ruler or indication printed on their surface that can be matched with a measurement template supplied by the manufacturer in order to determine the degree of tension on the plastic material.

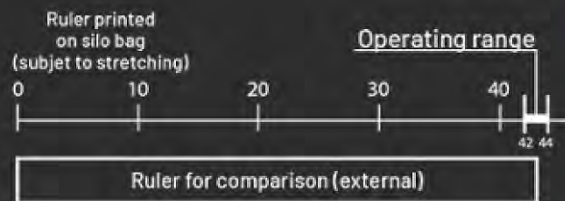

- 2 It is safer to stay in the centre of the grain bag's stretching range so as to allow for further grain settling.

Apart from checking this on the grain bag, it is most important not to exceed **150 bar**.

- 3 If, the bagging machine wheels skid due to wet ground or loose soil, the pressure of the hydraulic brake circuit must be reduced. As a last resort, if this is not enough, the tractor's brake can be used to contribute to braking both machines, but the purpose of the bagging machine wheels is to rotate, not to skid.

4

Make sure the grain bag is unfolded gradually, one fold at a time.

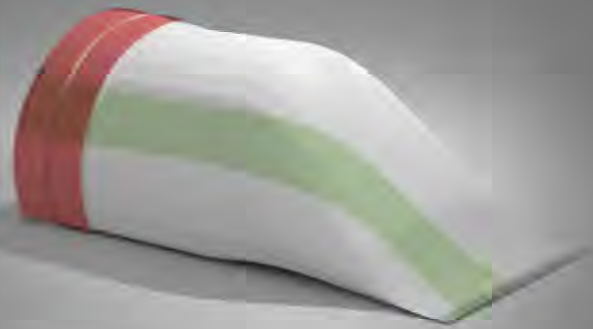

Grain is not able to move the machine forward without covering the auger with grain. An easy way to see this situation is when the height of the bag coming out of the machine is near or above the baggers tunnel height. If under this situation the brake pressure is not properly adjusted, the auger will work as a pressure device to fill the bag and the entire transmission system will be working under high torque demands that can break the PTO's shear-bolt.

6-C. PROTECTION AGAINST OVERLOADS

In the machine's driveshaft intake there are mechanical fuses, consisting of screws that will break if there is any overload in the transmission.

These screws should never be modified under any circumstances, since they guarantee the machine's integrity and its correct operation. In order to reestablish transmission, replace the broken screw using the indications given in the following table:

Walterscheid driveshaft

Size	Grade	Type	Surface protection	Quantity screw
M8X1.25X60	8.8 DIN -ISO 931-960	hexagonal head	Zincado o Cadmiado	1

Bondioli & Pavesi driveshaft

Size	Grade	Type	Surface protection	Quantity screw
M10x1.5x50	8.8 DIN -ISO 931-960	hexagonal head	Zincado o Cadmiado	1

6-D. INTERRUPTIONS DURING BAGGING

If the bagging operation has to be temporarily interrupted, this procedure will have to be followed



1

Stop feeding grain into the receiving hopper of the bagging machine. The auger should be left rotating in order to remove all the grain left inside the receiving hopper and the conveying tube.



2

Wait for a moment until the auger conveys all the remaining grain from the receiving hopper to the grain bag. The tractor and bagging machine will stop moving almost as soon as the hopper and the conveying tunnel are emptied.

3

By this time, the auger will be rotating unloaded. Gradually, reduce PTO speed until it stops, when the auger will also stop rotating.

4

Apply the tractor's hand brake as well, to make sure to prevent any grain bagger and tractor additional unexpected movement.



5

If any maintenance, repair or inspection tasks need to be carried out on the machine, uncouple the driveshaft from the tractor PTO and prop it on the towbar end support as shown in the figure.

6

If the tractor must temporarily leave the bagging site, release the towbar adjustment ratchet until the tractor hitch pin can be removed.

WARNING: If the machine is left attached to a semi-prepared grain bag and the driving tractor is removed, care should be taken that the pressure of the hydraulic brake system does not fall. It is best to place wedges on both sides of the machine wheels in order to avoid unexpected movements.

OPERATION AT THE END OF THE GRAIN BAG

Most grain bags have some kind of indication printed on their surface, e.g. a colored stripe, to show that the bottom end is being reached. When this kind of indication appears, or when there are about 4 (four) grain bag folds left on the silo tunnel, proceed as follows:

1

Follow instructions 1, 2 & 3 from the previous paragraph, **6-d "Interruptions during Bagging"**.

2

Apply the tractor's hand brake. If the tractor's hand brake is not in a good condition, it is best to stop the tractor engine and leave it in a low gear.

3

Once the bagging machine is properly held by the tractor, release its own built-in brakes.

4

Gradually release the tractor's hand brake and use a low gear at the same time if necessary. In this way, the pressure exerted by the remaining cereal will push the bagging machine-tractor assembly forward an additional distance.

5

Tow the bagging machine using the tractor until the portion of the grain bag left on the machine's silo tunnel is finally released.

The bottom end of the silo bag will then be completely free to be closed.

6-F. CLOSING THE GRAIN BAG

In general terms, the following grain bag closing methods can be explained.

- Plastic Closure
- Wooden Boards
- Ropea

MAINTENANCE

CARE PROCESSES FOR THE CORRECT OPERATION OF THE MACHINE.



7-A. MAINTENANCE SCHEDULE

The machine is simple, so the only maintenance tasks necessary are the following.

DAILY TASKS

GENERAL MACHINE CONDITION

TASK: Eliminate causes of possible restrictions on the movements; remove any dirt that could hinder the machine's operation.

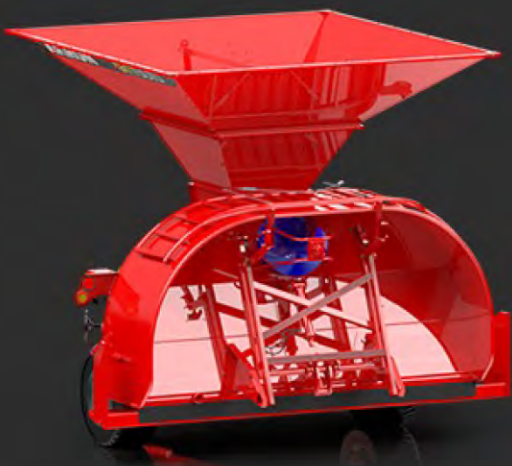

CONDITION OF THE CONVEYING AUGER TUBE

TASK: Eliminate possible obstructions or dirt left inside the tube.

WEEKLY TASKS

TIRE PRESSURE

TASK: Adjust tire pressure. Between 2,7 and 3,4 bar (40 and 50 lb/pulg²), both tires at the same pressure



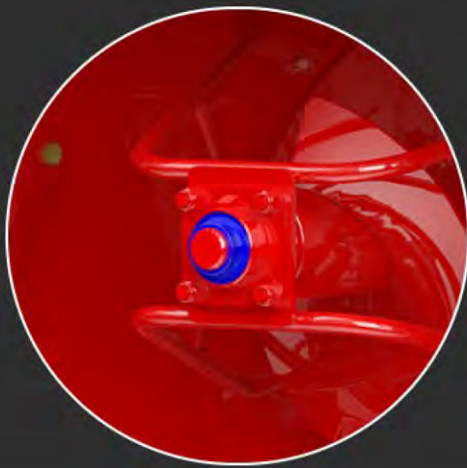

HALF-YEARLY TASKS

SUPPORT BEARINGS

TASK: Grease the bearings using the grease fittings supplied for this purpose. Use NLGI grade 2 lithium grease. If the problem is not solved, dismantle and evaluate possible replacement according to the instructions given in paragraph 7-d., under the title "Auger Support Bearing Replacement".

7-B. MAINTENANCE AFTER RECEIVING THE MACHINE

After some 30 hours of continuous operation, it is essential to re-tighten all the machine's screws using the following torque values recommended for SAE grade 5 zinc-plated screws:

Size	Torque [kgm - N.m (ft.lb)]	
1/ 4" - 20	0,96 - 9,5	(7,03)
5/16" - 18	2,03 - 20	(14,81)
3/ 8" - 16	3,61 - 35,5	(26,29)
7/16" - 14	5,81 - 57	(42,22)
1/ 2" - 13	8,86 - 87	(64,44)
9/16" - 12	12,74 - 125	(92,59)
5/ 8" - 11	17,58 - 172	(127,77)
3/ 4" - 10	31,29 - 307	(227,40)

CHAIN TENSION:

Adjust the chain until the free strand can move freely $3/8"$ to $5/8"$ (10 to 15 milimeters) using light hand force.

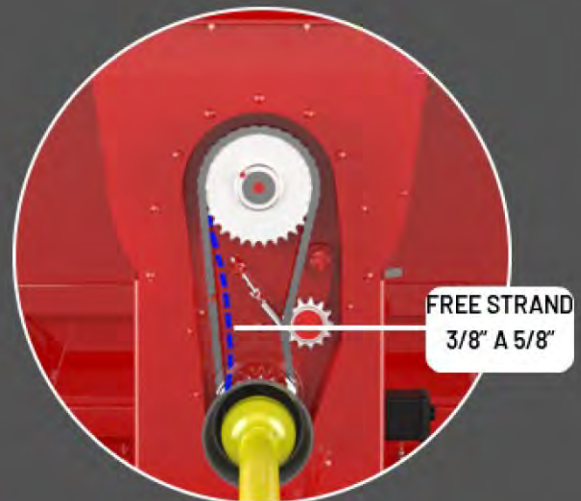

7-C. LUBRICATION

NLGI grade 2 lithium (multiple-purpose automotive) grease is recommended for all the lubrication points.

7-D. REPLACEMENT OF PARTS SUBJECT TO WEAR

AUGER SUPPORT BEARING REPLACEMENT

- 1) Identify the UC 209 bearing and release the Allen studs that fix it to the rear shaft end.
- 2) Remove the hex head screws ($1/2"$) from the support to remove it. Care must be taken to prevent the auger from falling suddenly on the support.
- 3) Insert the UC209 bearing on the rear shaft end. Then, position the support and tighten the hex head screws ($1/2"$) on the rear support.
- 4) Tighten the Allen studs that fix the bearing.

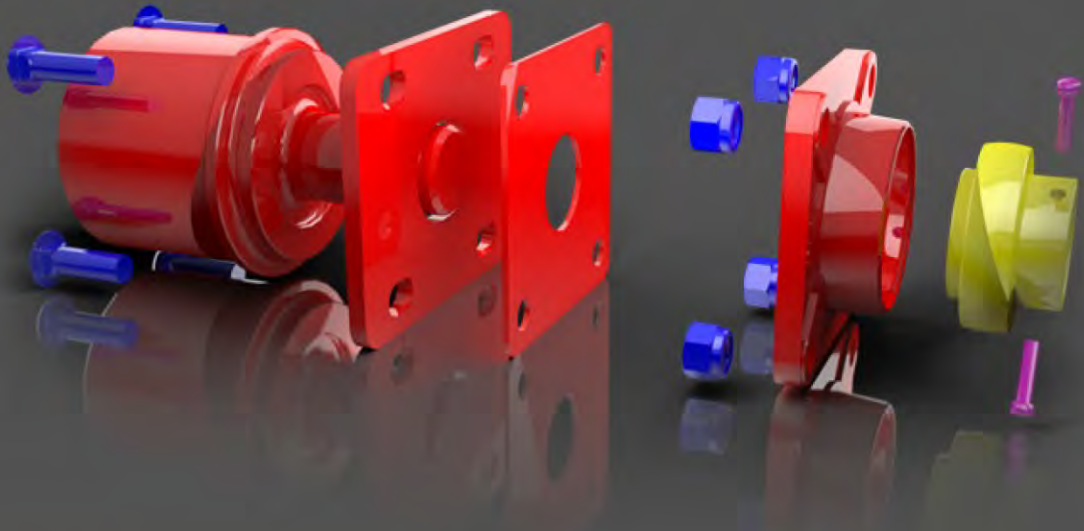

7-E. BRAKE FLUID

Brake fluid level should regularly be checked. The tank should be at half point approximately. Brake fluid should be Type 3.

7-F. WEAR PREVENTION ON FLEXIBLE PIPES

Take into account the following items for a better use and take care of the flexible pipes included in the machine.

- Visually inspect each one of the brake hydraulic circuit components and hoses. They should not have leakages: Keep them from touching sharp objects. Do not tread on hoses and keep them from being strangled.
- Be careful when working with brake liquid, since it can cause burns on your skin and wearing on metal parts.
- Check the helical cover on the hydraulic circuit is in good condition in order to prevent the operator from being splattered with fluid

7-G. TIRE CHANGE

Follow the below steps:

- 1 Slightly loosen the wheel nuts.
- 2 Lift the machine using a mechanical or hydraulic jack applied to the chassis in the location indicated by the decal, as shown in Figure
- 3 Once the bagging machine has been lifted, install the assembled wheel and the five wheel nuts.
- 4 Tighten the wheel nuts using a 21 mm hexagonal wrench up to a final tightening torque of 9 kgm = 90 Nm = 65 ft lbs. pie.



IMPORTANT: Remember to re-tighten wheel nuts during the first 3 weeks for them to fit better on the wheel rims.

SPECIFICATIONS

TECHNICAL DETAILS OF THE GTT
5010 GRAIN BAGGING MACHINE.



9-A. LIST OF MAIN COMPONENTS

Tare: 1800 kg

Tunnel: For grain bags up to 10 fe

Working capacity: 1400 ton / hr.

Operation: Tractor with 90HP available in the PTO, with a rotation speed rating of 540 RPM.

Tube / auger: Ø 600 mm, reforzado de 4,76 mm de espesor.

Braking system: Hydraulic, with built-in manual pump.

Towbar height adjustment: Enough to absorb differences in the hitch.

Transport position: No wheel configuration changes are required

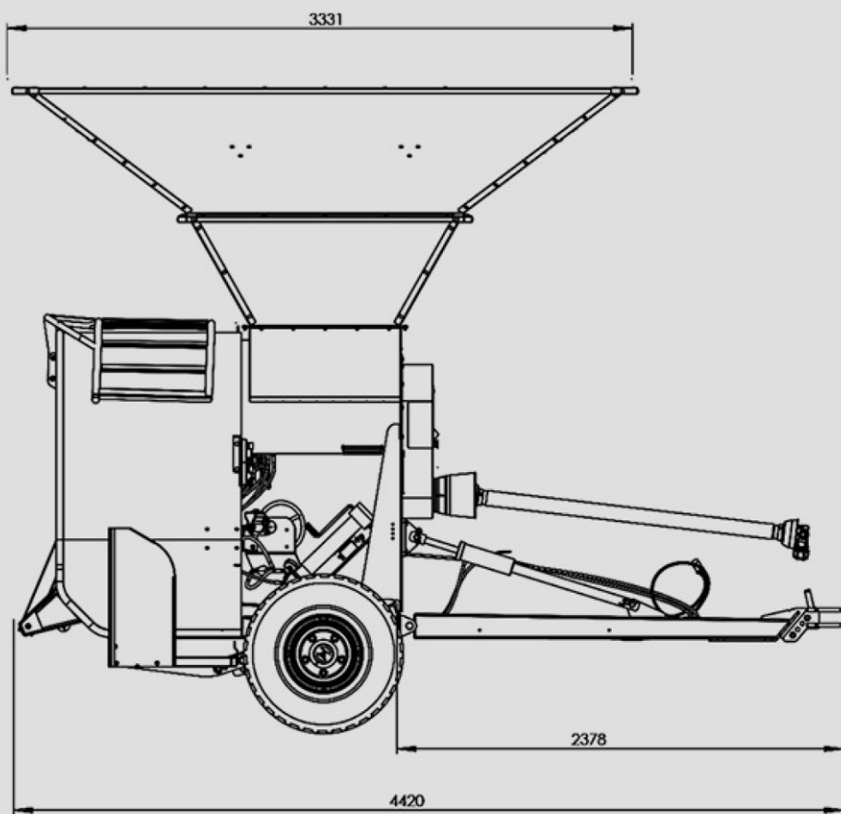
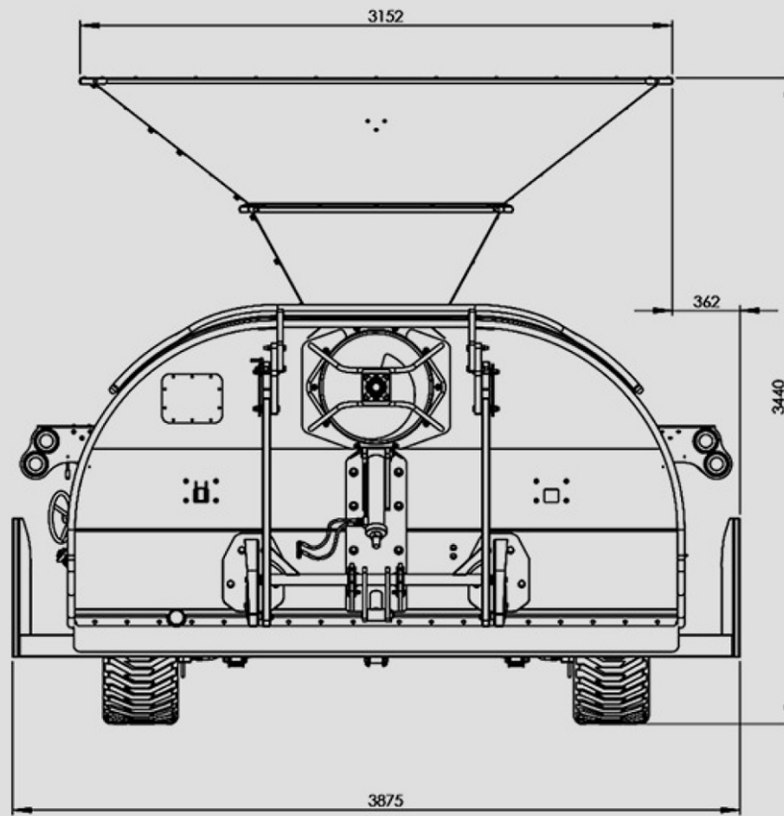

GUARANTEE TERMS



11. GUARANTEE

AKRON S.A. guarantees the **AKRON® GTT 5010** grain bagging machine for a one-year period since the date in which the new unit is delivered to the customer. This guarantee covers defects in materials used to manufacture the machine, provided that the grain bag unloader has been properly operated. The operating procedures considered appropriate are those described in this manual.

This guarantee does not cover the following:

Damages or failures as a result of improper operation or lack of machine maintenance that may occur during transport, operation, or parking from the delivery date.

Tires are warranty of the tire manufacturer.

Normal wear of parts due to their use. Their replacement is part of the preventive maintenance.

AKRON S.A. is not responsible for any repair made by third parties, or damages resulting from this cause.

AKRON S.A., reserves the right to modify the guarantee terms without previous notice.

AKRON S.A. reserves the right to modify specifications and designs without previous notice and without the obligation to implement these changes in the machines already delivered.

Damages caused during machine operation by any person whose abilities are affected or reduced will not be covered.

If the machine is sold by the first owner within the guarantee term validity, this will be transferred to the new owner, provided that AKRON S.A. is advised by written notice. Such guarantee will not be valid if the current owner of the machine (not being the original buyer of the product) has not advised AKRON S.A. in due time.

The guarantee will automatically become invalid if any of the parts of the machine is modified or replaced by spare parts not provided by AKRON S.A. If such replacement or structural modification was urgently necessary, the user must obtain written approval from AKRON S.A. to make such changes without affecting these guarantee terms.

In order for the guarantee to come into force, it is an essential condition to submit a request for guarantee repair together with the following information:

Name:

Date in which the damage occurred:

City:

Phone Number:

Machine Model:

Serial Number:

Invoice Number:

PARTS

SUBJECT TO NORMAL WEAR AND TEAR

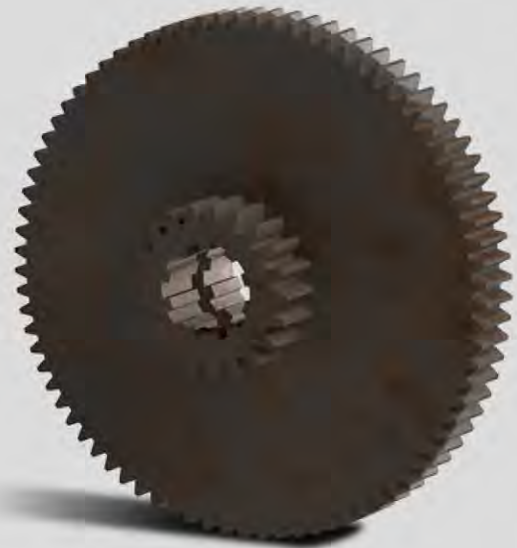

13. PARTS SUBJECT TO NORMAL WEAR AND TEAR:

Ordinary maintenance and spare parts replacement services of the parts detailed below are the equipment owner's exclusive responsibility, therefore, they will not be considered defects in material or manufacturing, but rather defects due to normal wear and tear; improper operation or insufficient equipment maintenance.

- Chains - Augers - Bearings - Wheels - Sprockets - Brake System (brake pad ; shoe linings) - Wear due to grain friction

PARTS SUBJECT TO IMPROPER OPERATION OR INSUFFICIENT MAINTENANCE.

Using the gearboxes without normal oil level or not complying with the transmission inlet specifications described in the user's manual.

Altering the maximum inlet torque (shear bolt system on PTO).

MACHINE	MAXIMUM ALLOWED INLET TORQUE	PROBABLE CAUSES THAT CAN ALTER THE MAXIMUM ALLOWED TORQUE
GTT 5010 BAGGER	2130N/m	Replacing the PTO with a PTO with no shear pin device installed.

Wheel nuts: After around 30 hours of running or after changing a wheel, wheel nuts must be retighten according to the torque values detailed in the manual (9 kgm = 90 Nm = 65 ft lbs. pie -point 7.g). Special care should be taken to the wheel nuts tightening if the machine has moved over paths or roads. Failure to follow these instructions may cause rim damage or lost of it.

OPTIONAL GTT5010

WORK LIGHTS

Electrical control fixed on the bagging column. These reflectors are located in the upper part of the hopper and are used to work with the machine at night.

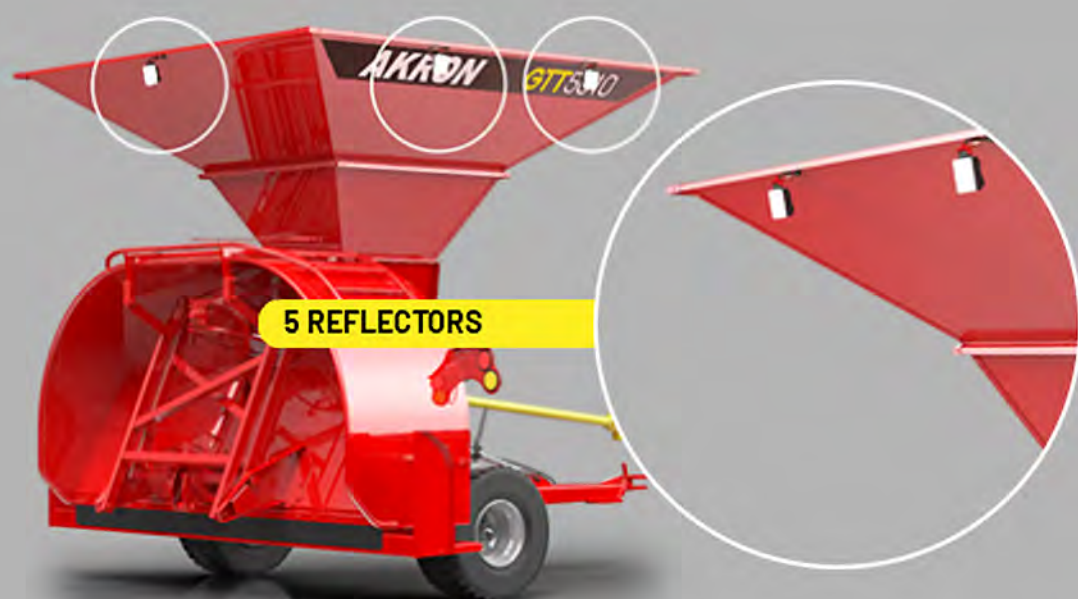

LEVELING RATCHET FOR THE TOWBAR

To operate a manual adjusting of the machine's inclination.



HYDRALIC BRAKE

The hydraulic brake admits 2 positions according to the preference of the user.







AKRON
GTT 5010

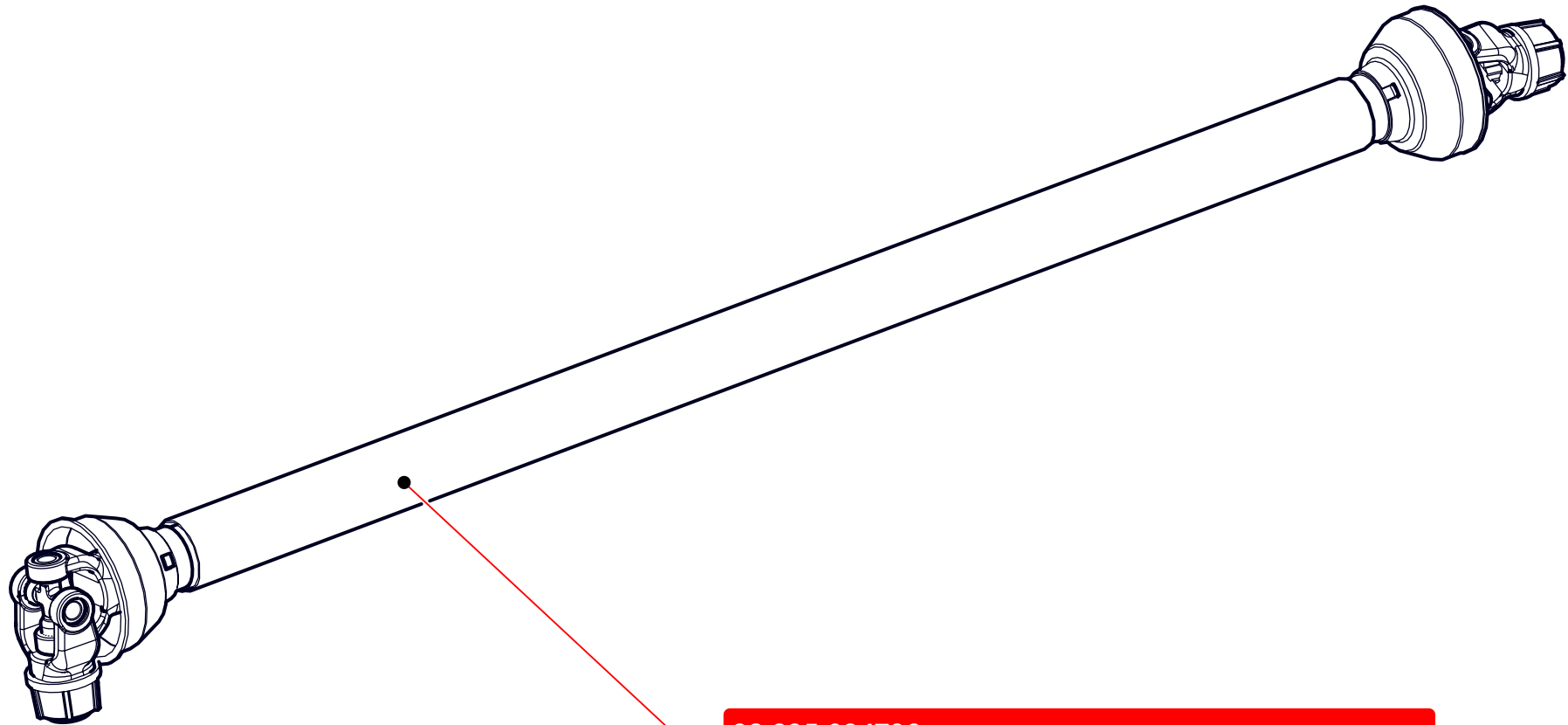

PARTS LIST

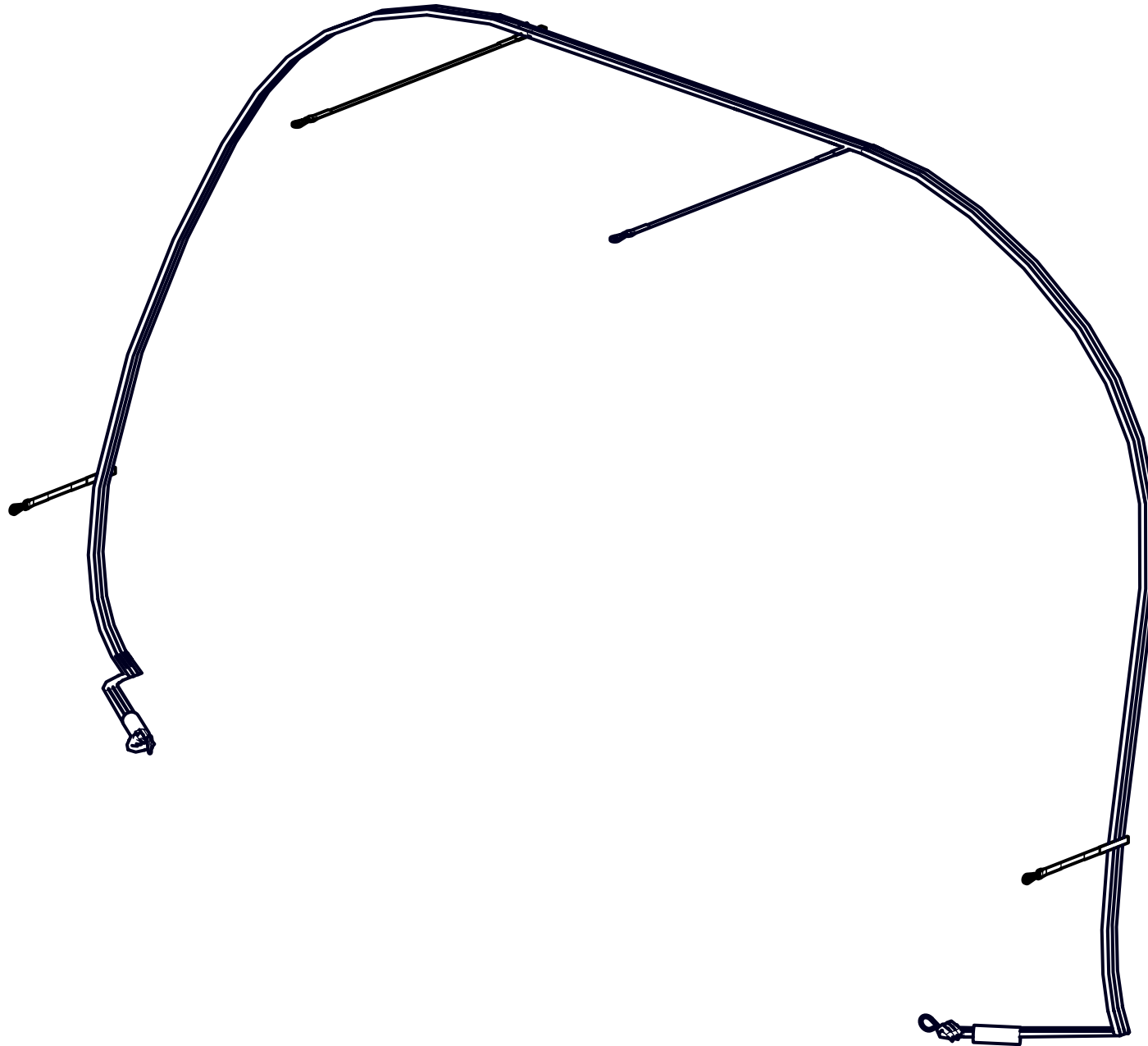

98.395.034796
Shear pin setting 1860 Nm - Shear Pin M8 x 1.25 x 50 G8.8
(MICRON/EDMA CARDAN SHAFT)



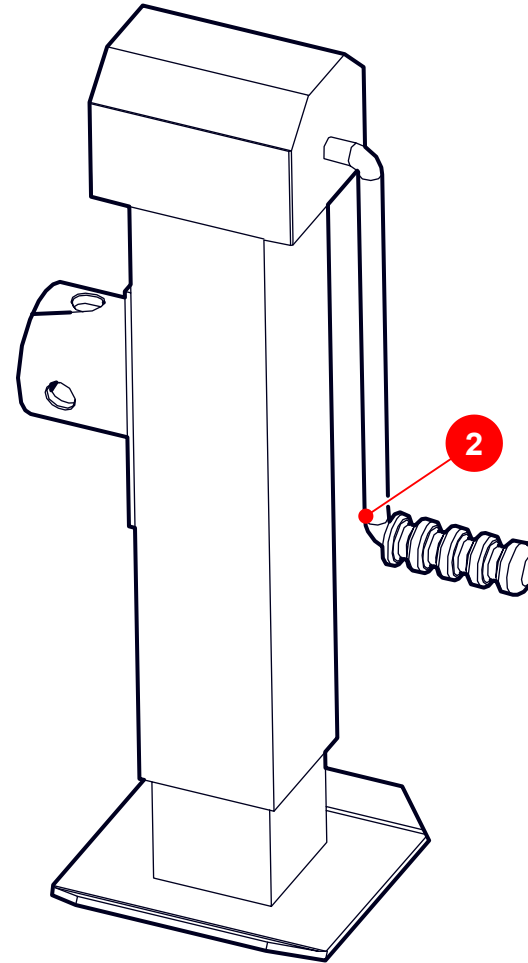
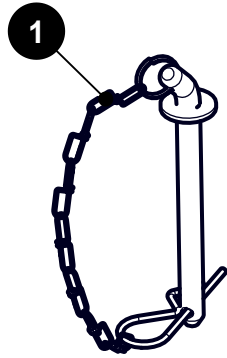

N°	PART	DESCRIPTION	QTY
1	25.39.14280	-- Latch	1
2	98.395.028170	Mechanical Jack	1

● AXLE - COLUMN ASSEMBLY

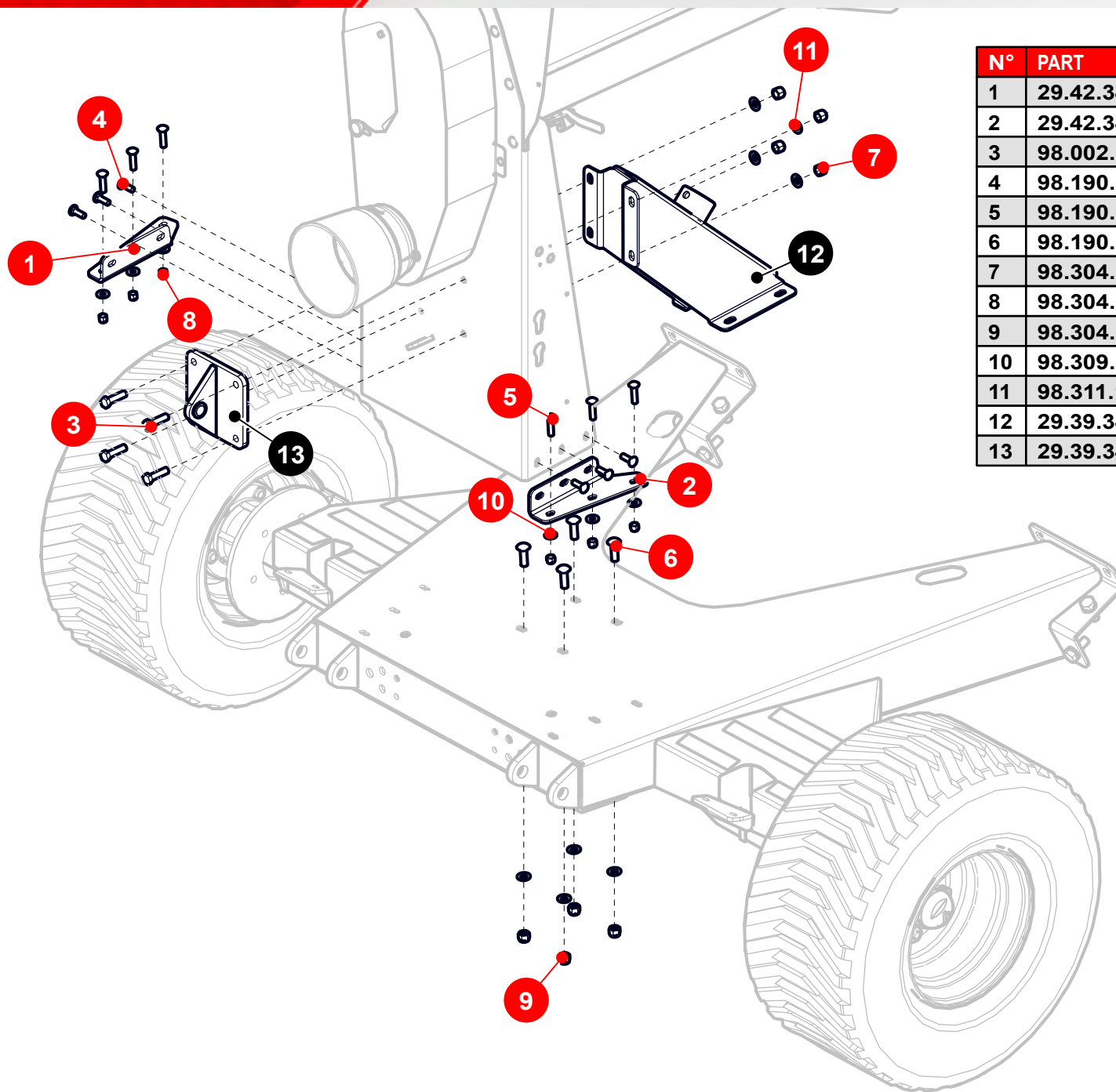

N°	PART	DESCRIPTION	QTY
1	29.42.34322	- - Support	1
2	29.42.34323	- - Support	1
3	98.002.158057	- Hex. Head Screw	4
4	98.190.127038	- Round head square neck	6
5	98.190.127051	- Round head square neck	6
6	98.190.158051	- Round head square neck	4
7	98.304.110158	- Lock Nut W 5/8" X11	4
8	98.304.151127	- Lock Nut G5 1/2" RW	6
9	98.304.151158	- Lock Nut W 5/8"	4
10	98.309.101127	- Flat Washer Ø 1/2"	6
11	98.311.101158	- Chamfered Washer 5/8"	7
12	29.39.34330	- - Reinforcement	1
13	29.39.34340	- Support Assembly	1

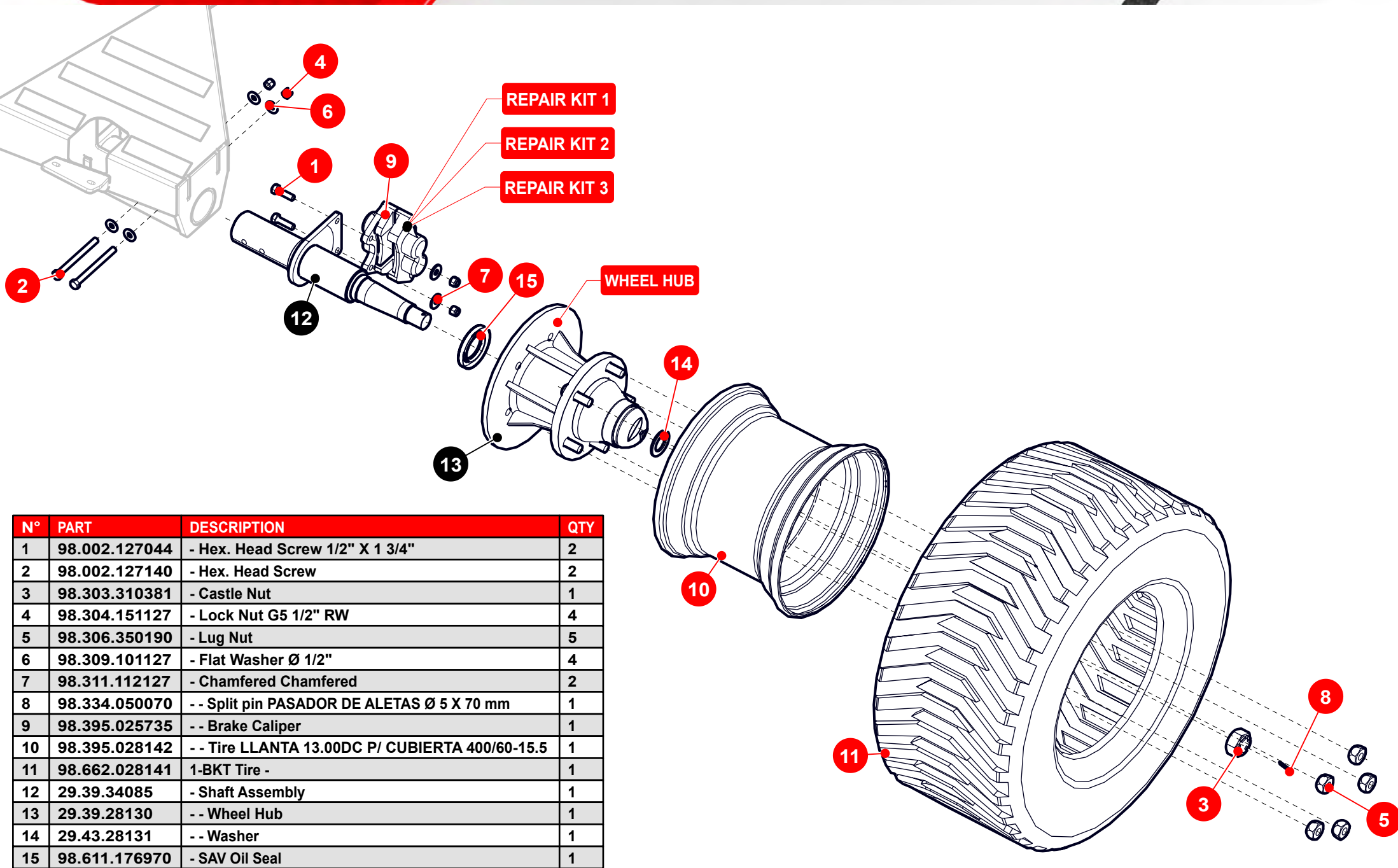

N°	PART	DESCRIPTION	QTY
1	98.002.127044	- Hex. Head Screw 1/2" X 1 3/4"	2
2	98.002.127140	- Hex. Head Screw	2
3	98.303.310381	- Castle Nut	1
4	98.304.151127	- Lock Nut G5 1/2" RW	4
5	98.306.350190	- Lug Nut	5
6	98.309.101127	- Flat Washer Ø 1/2"	4
7	98.311.112127	- Chamfered Chamfered	2
8	98.334.050070	-- Split pin PASADOR DE ALETAS Ø 5 X 70 mm	1
9	98.395.025735	-- Brake Caliper	1
10	98.395.028142	-- Tire LLANTA 13.00DC P/ CUBIERTA 400/60-15.5	1
11	98.662.028141	1-BKT Tire -	1
12	29.39.34085	- Shaft Assembly	1
13	29.39.28130	-- Wheel Hub	1
14	29.43.28131	-- Washer	1
15	98.611.176970	- SAV Oil Seal	1

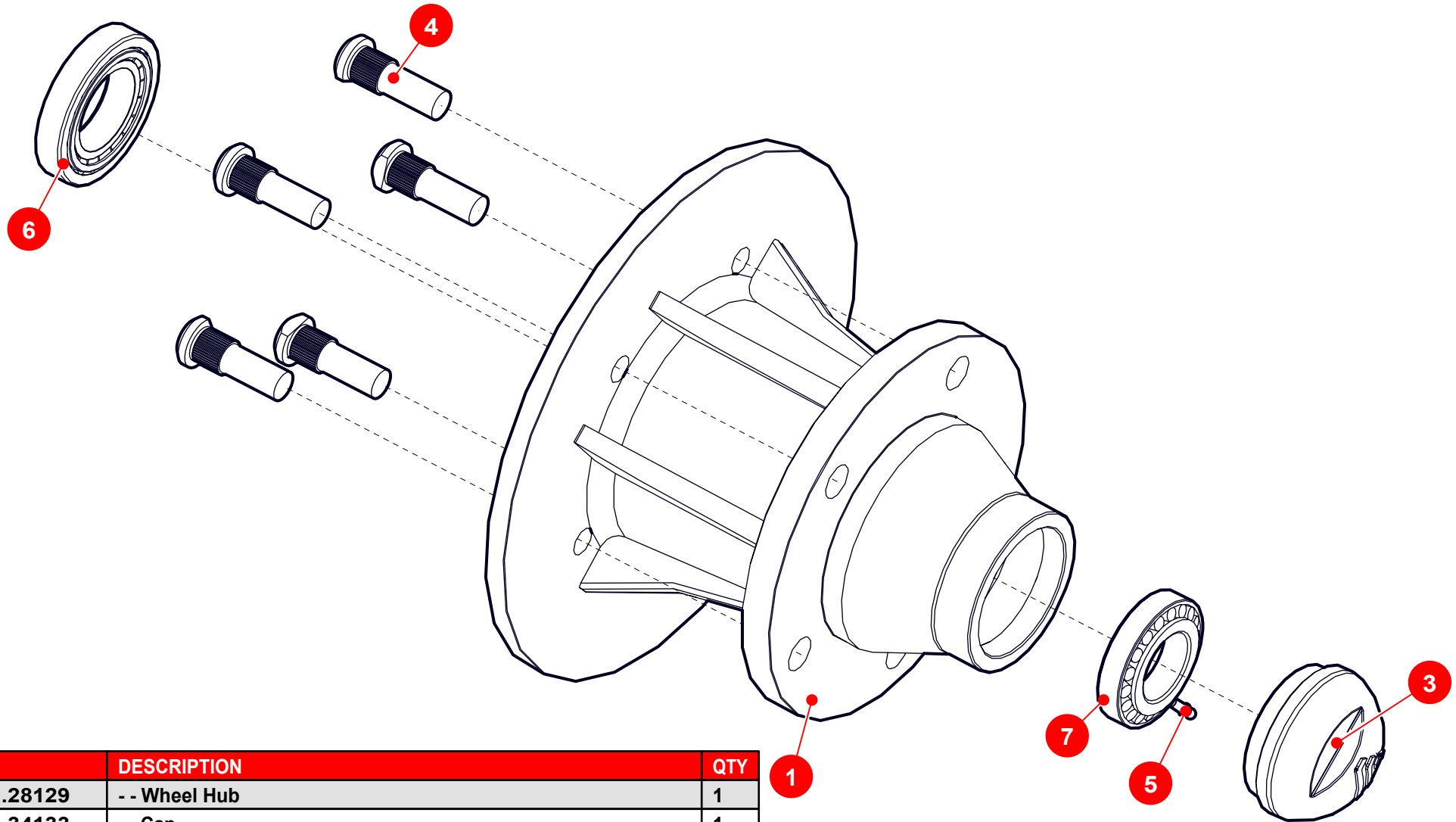

N°	PART	DESCRIPTION	QTY
1	29.41.28129	-- Wheel Hub	1
3	29.41.34133	-- Cap	1
4	98.232.190062	- Hub Screw	5
5	98.460.310063	Straight Grease Fitting ALEMITE RECTO PROLONGADO 1/4 NF	1
6	98.730.330155	-- Bearing RODAMIENTO 30211	1
7	98.730.330945	-- Bearing RODAMIENTO 30209	1

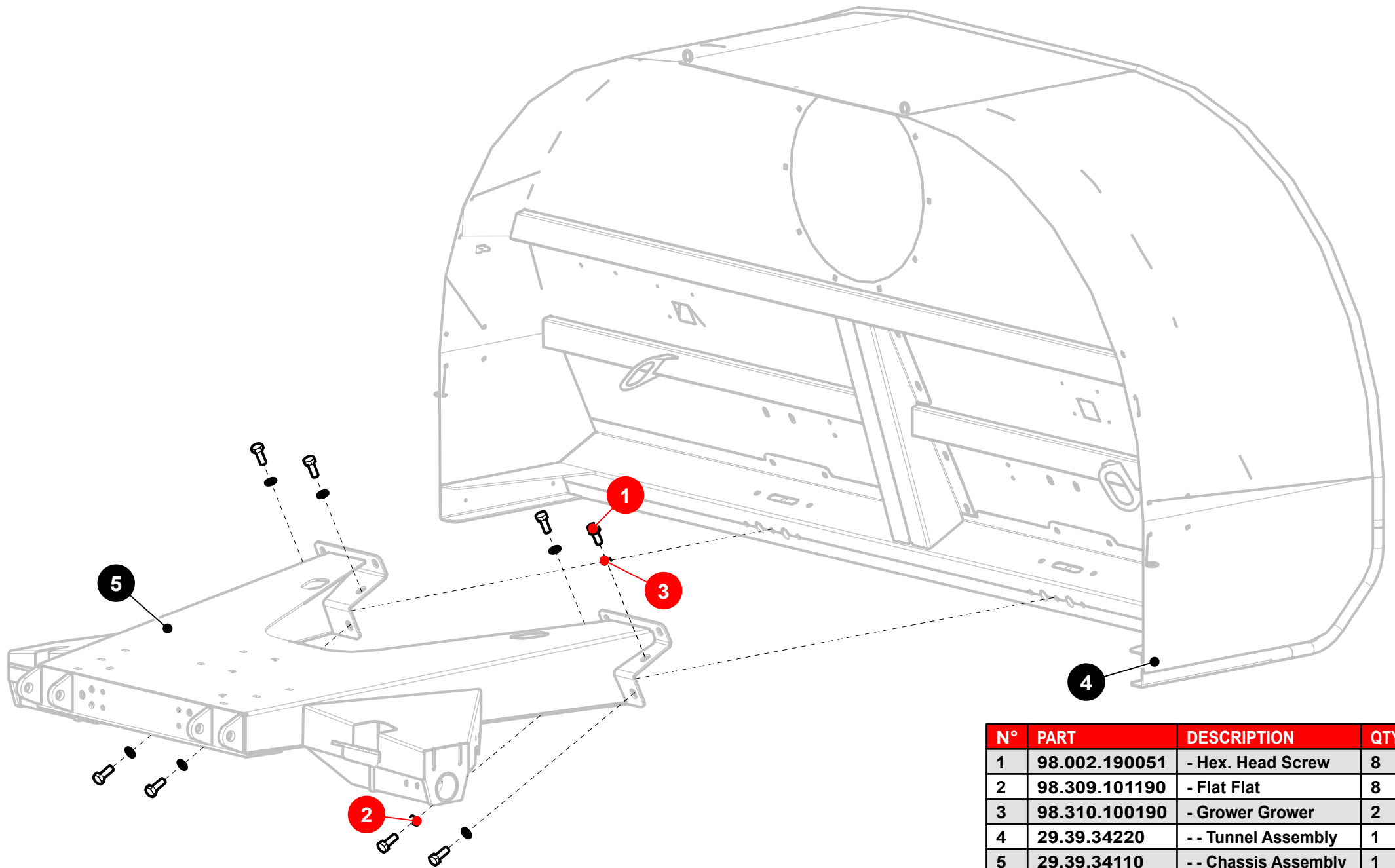

N°	PART	DESCRIPTION	QTY
1	98.002.190051	- Hex. Head Screw	8
2	98.309.101190	- Flat Flat	8
3	98.310.100190	- Grower Grower	2
4	29.39.34220	- - Tunnel Assembly	1
5	29.39.34110	- - Chassis Assembly	1

● CYLINDER - TOWBAR ASSEMBLY

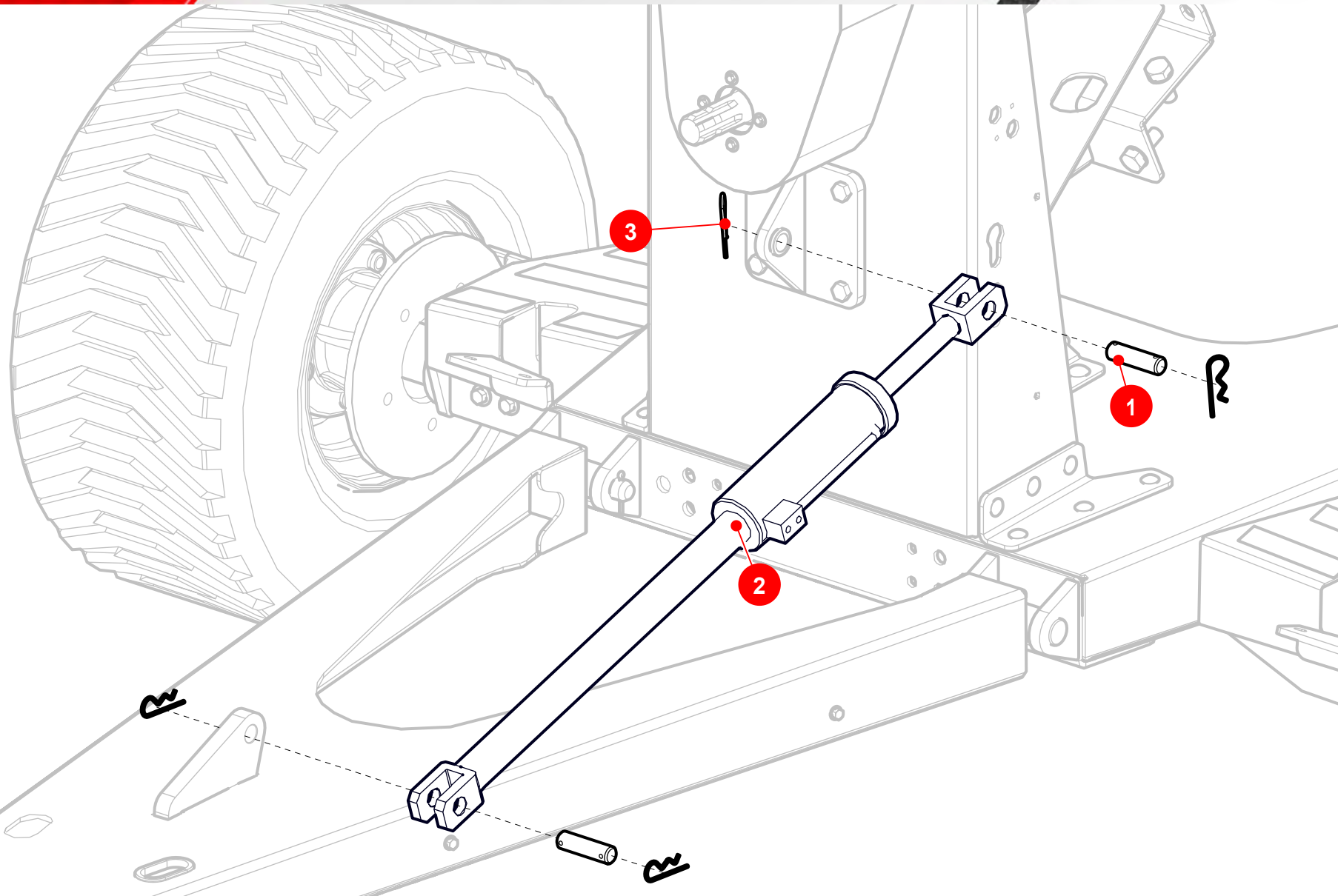

N°	PART	DESCRIPTION	QTY
1	29.43.24187	-- Lock Pin	2
2	98.378.034903	-- Hydraulic Cylinder	1
3	98.380.040090	-- R Pin CLIPS Ø 4x LONG. 90 MM	4

N°	PART	DESCRIPTION	QTY
1	29.39.34710	-- Towbar	1
2	29.39.34715	-- Hitch	1
3	29.43.34708	-- Lock Pin	2
4	98.334.050060	-- Split pin PASADOR DEALETA Ø 5 X 60 mm	2
5	98.378.021016	-- Press fit pipe PRENSA CAÑO HIDRAULICO 5/8"	2

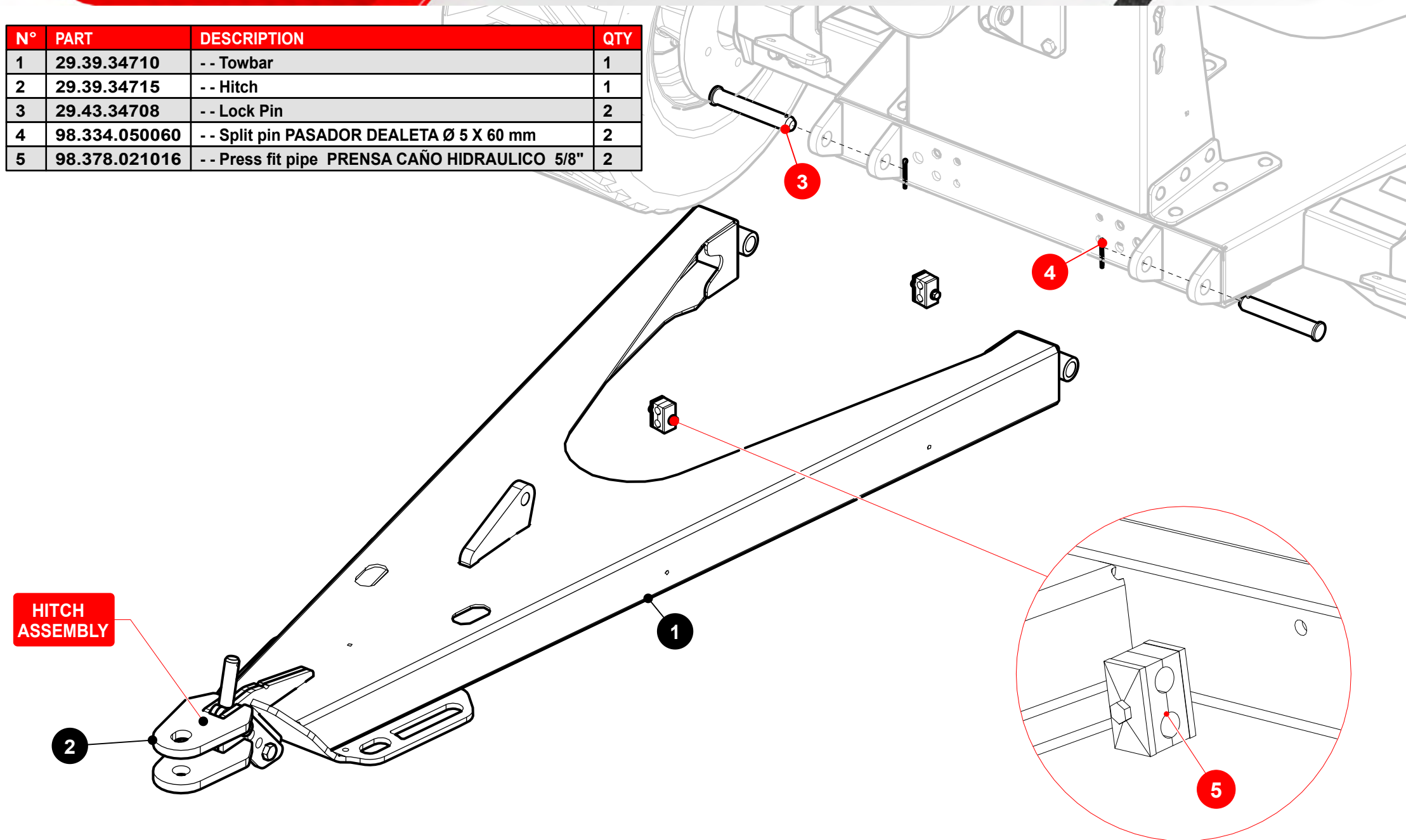

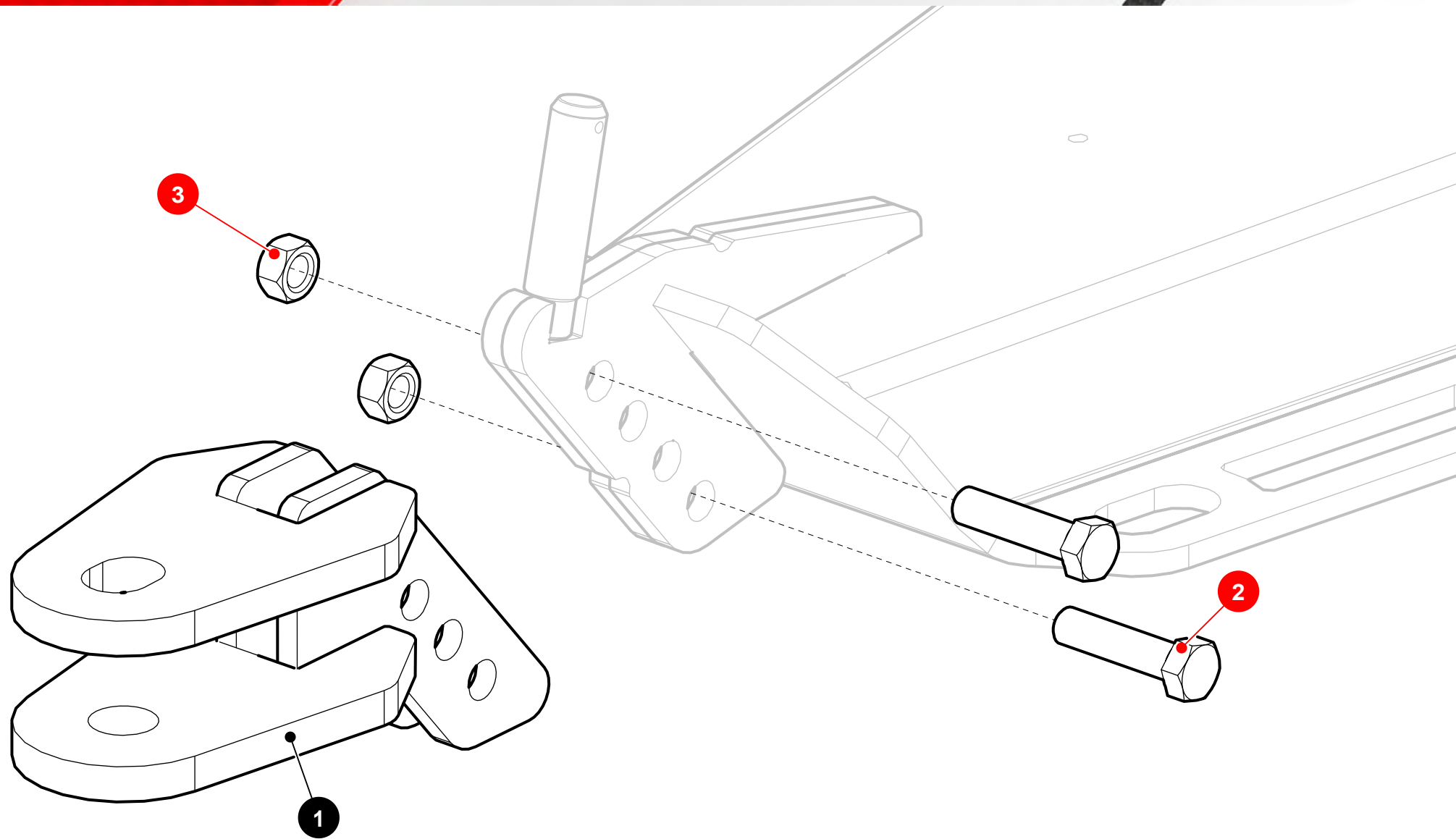

N°	PART	DESCRIPTION	QTY
1	29.39.34715	-- Hitch	1
2	98.002.190076	- Hex. Head Screw	2
3	98.301.150190	- Hex Nut TUERCA HEXAG. 3/4" RW G° 5	2

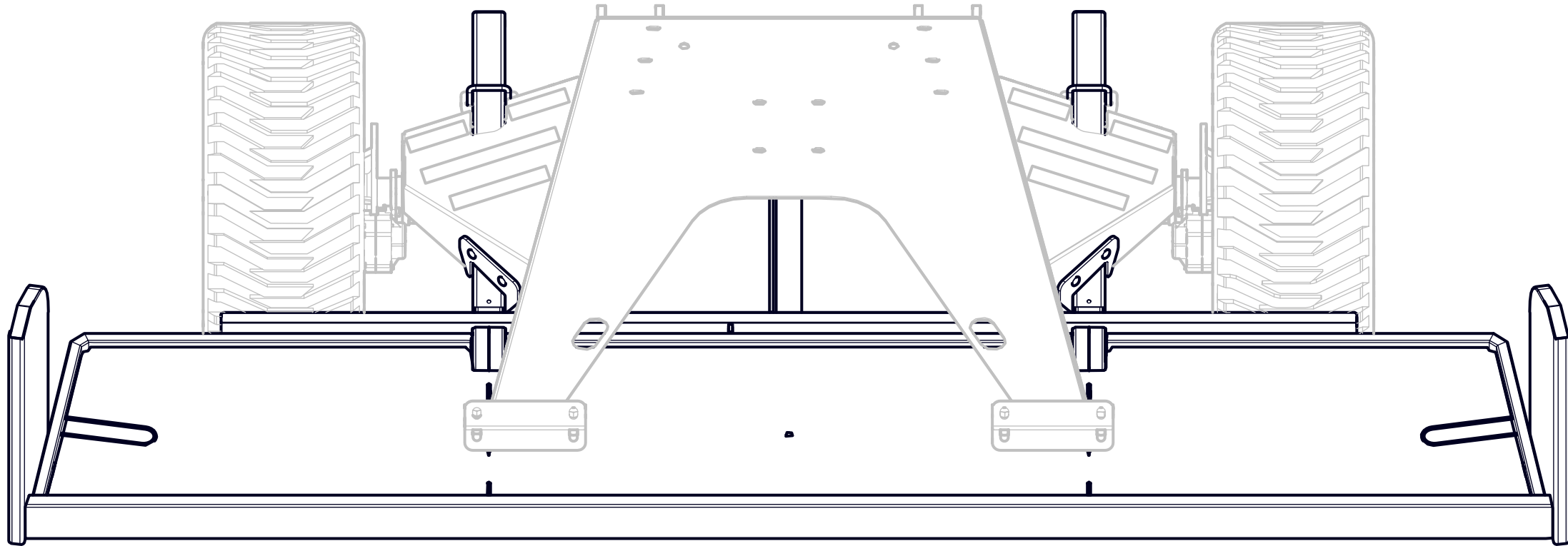

U CLAMPS

OUTER BAR/ CYLINDER

TELESCOPIC BAR

SIDE RETAINERS



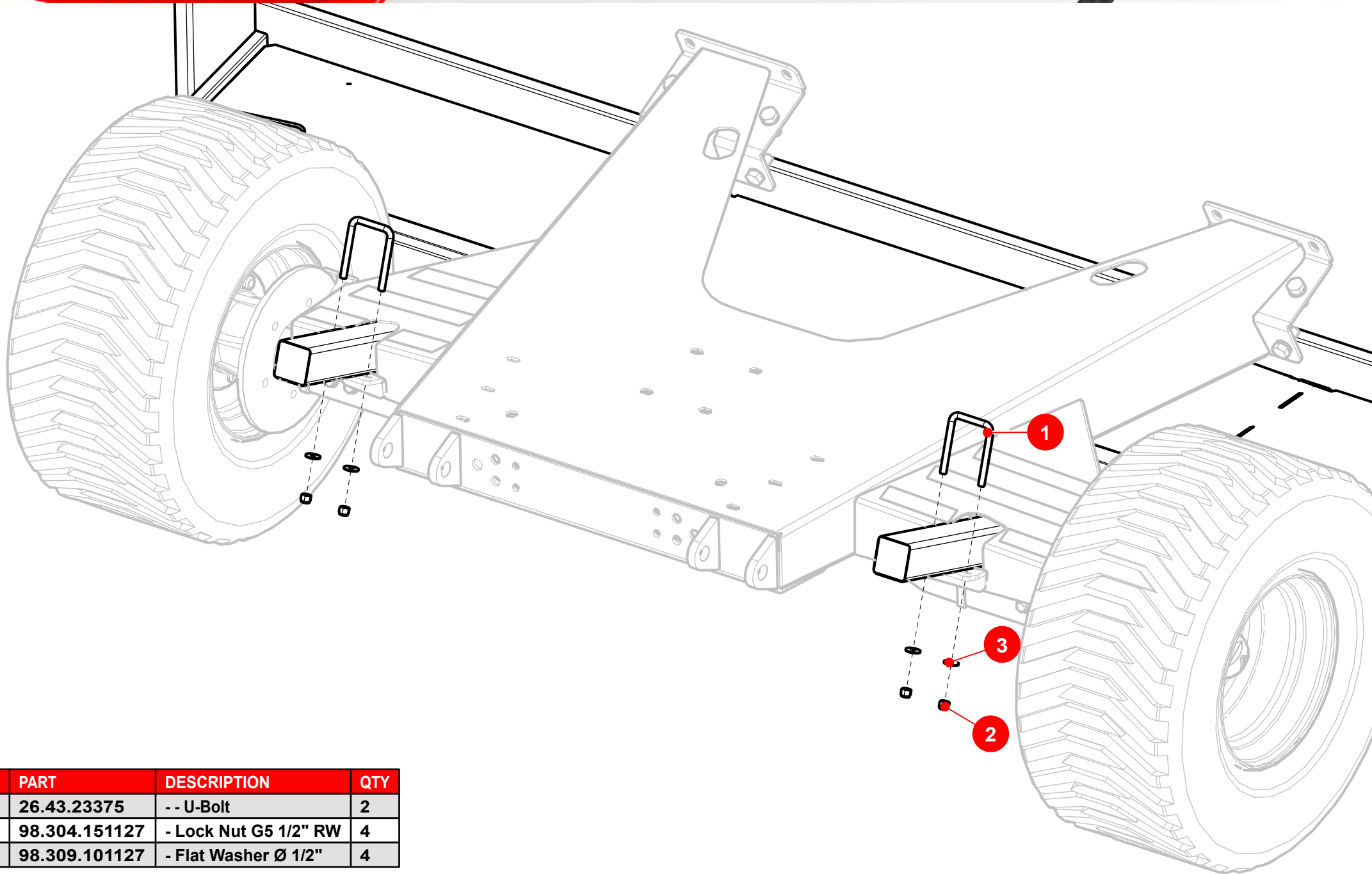

N°	PART	DESCRIPTION	QTY
1	26.43.23375	-- U-Bolt	2
2	98.304.151127	- Lock Nut G5 1/2" RW	4
3	98.309.101127	- Flat Washer Ø 1/2"	4

N°	PART	DESCRIPTION	QTY
1	29.43.35783	- - Lock Pin	2
2	29.43.35783	- Split pin	4
3	98.190.127038	- Round head square neck	4
4	98.304.151127	- Lock Nut G5 1/2" RW	4
5	98.309.101127	- Flat Washer Ø 1/2"	4
6	98.378.034901	- - Hydraulic Cylinder Rod Clevis 2" X 600mm	1

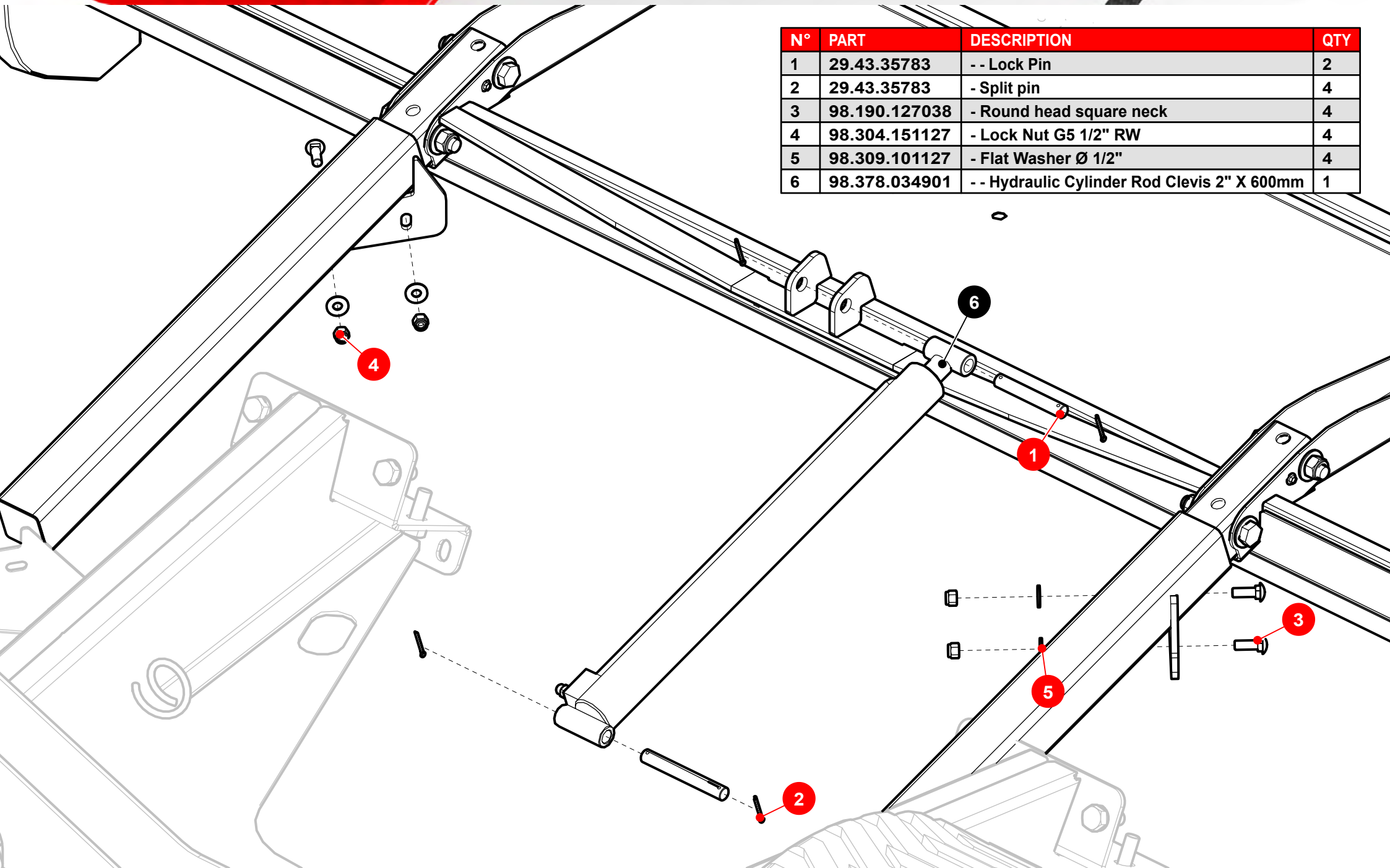

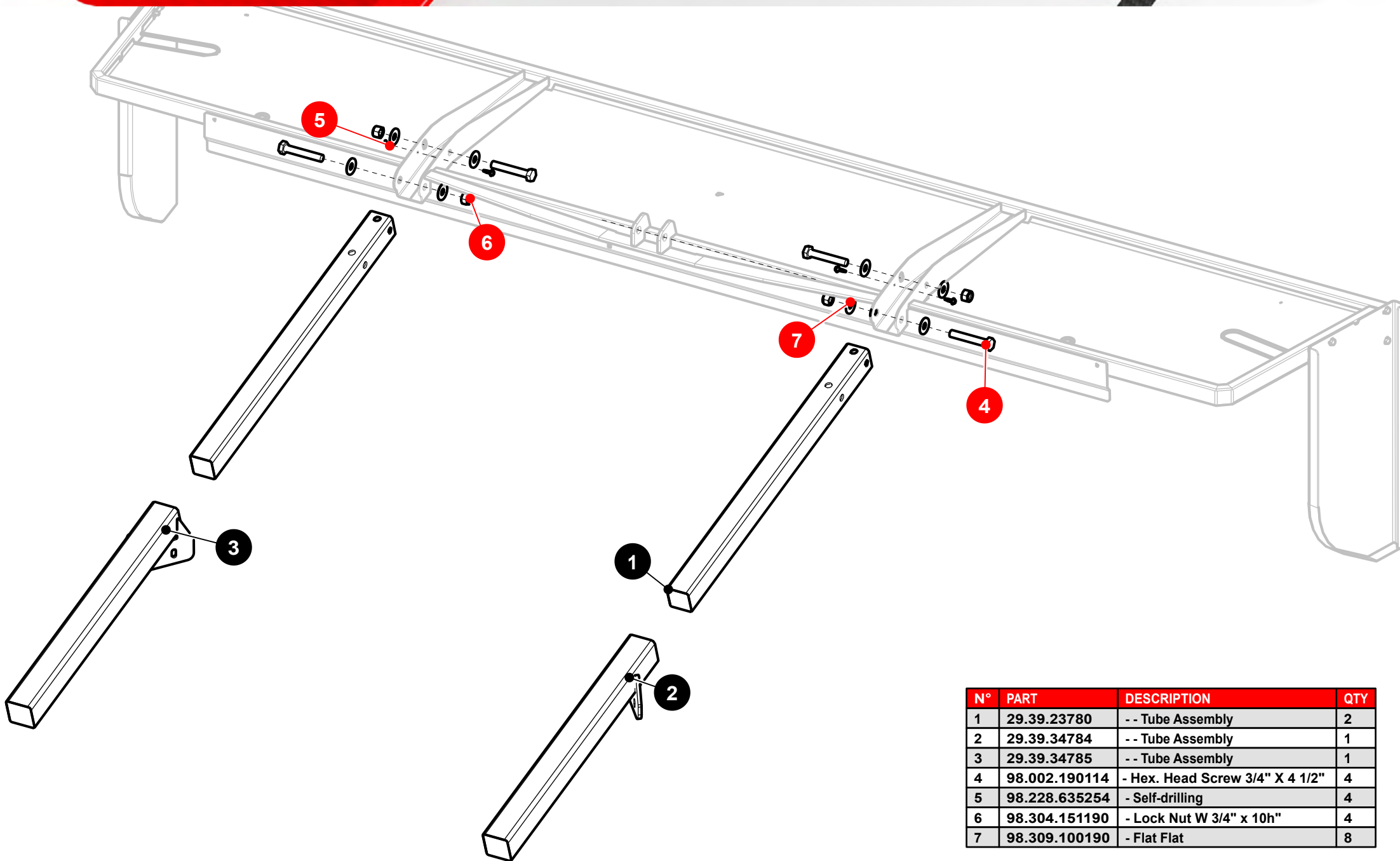

N°	PART	DESCRIPTION	QTY
1	29.39.23780	-- Tube Assembly	2
2	29.39.34784	-- Tube Assembly	1
3	29.39.34785	-- Tube Assembly	1
4	98.002.190114	- Hex. Head Screw 3/4" X 4 1/2"	4
5	98.228.635254	- Self-drilling	4
6	98.304.151190	- Lock Nut W 3/4" x 10h"	4
7	98.309.100190	- Flat Flat	8

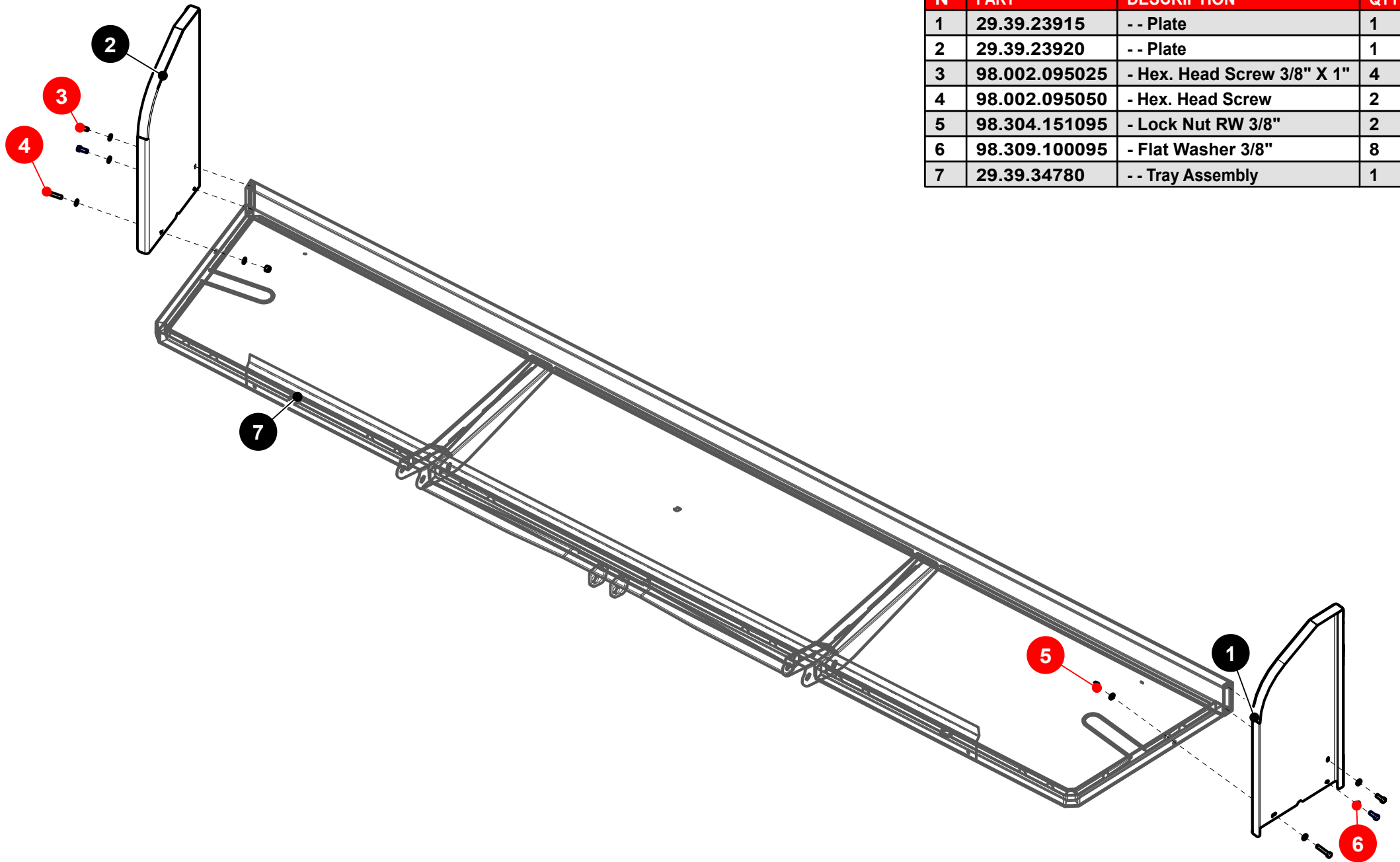

N°	PART	DESCRIPTION	QTY
1	29.39.23915	-- Plate	1
2	29.39.23920	-- Plate	1
3	98.002.095025	- Hex. Head Screw 3/8" X 1"	4
4	98.002.095050	- Hex. Head Screw	2
5	98.304.151095	- Lock Nut RW 3/8"	2
6	98.309.100095	- Flat Washer 3/8"	8
7	29.39.34780	-- Tray Assembly	1

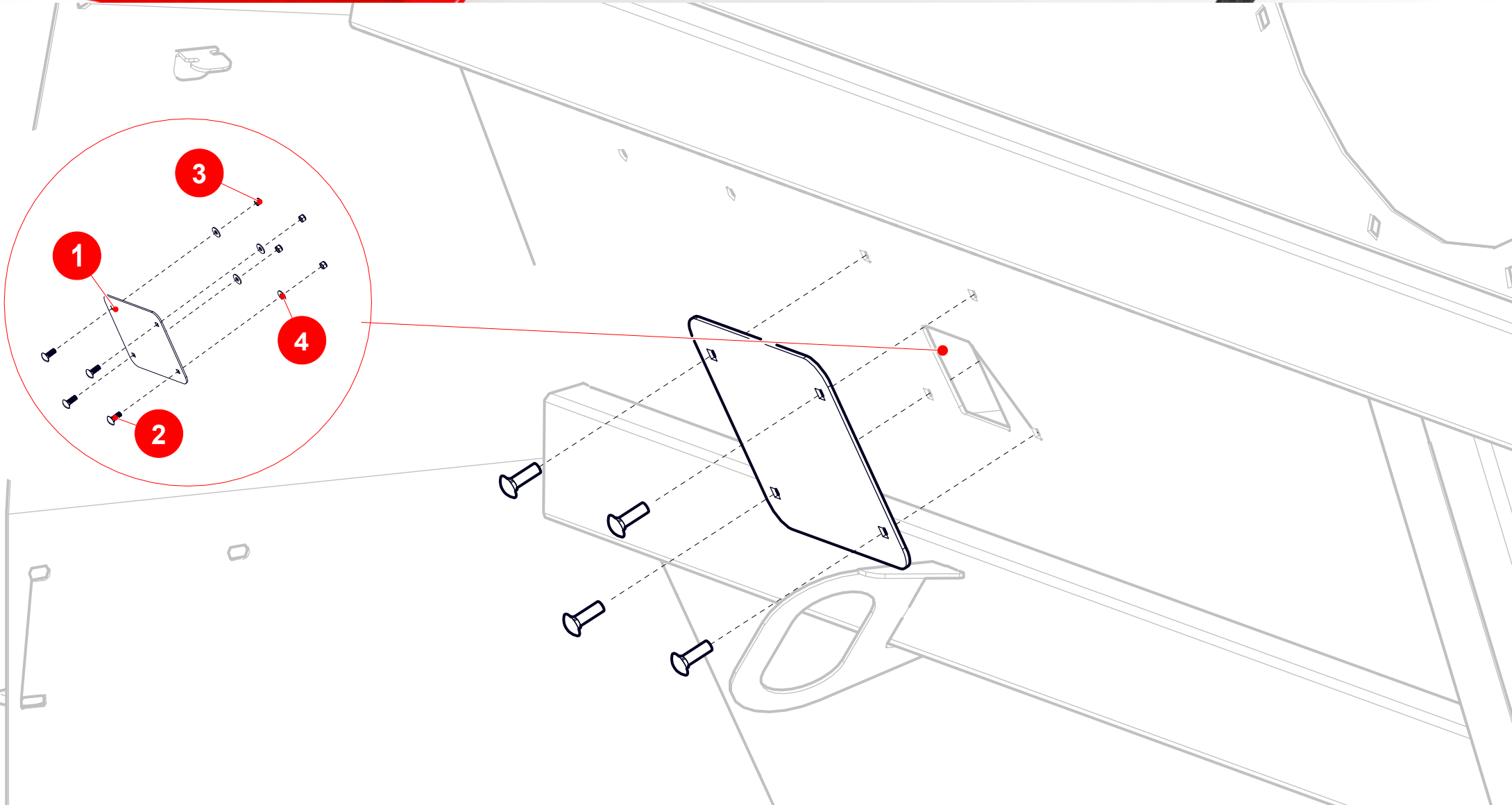

N°	PART	DESCRIPTION	QTY
1	29.42.33316	-- Cap	1
2	98.190.079025	- Round head square neck TORN.C/RED.CUELLO CUAD.G5 5/16" X 7/8" RW	4
3	98.304.151079	- Lock Nut W 5/16"	4
4	98.309.100079	- Flat Washer 5/16"	4

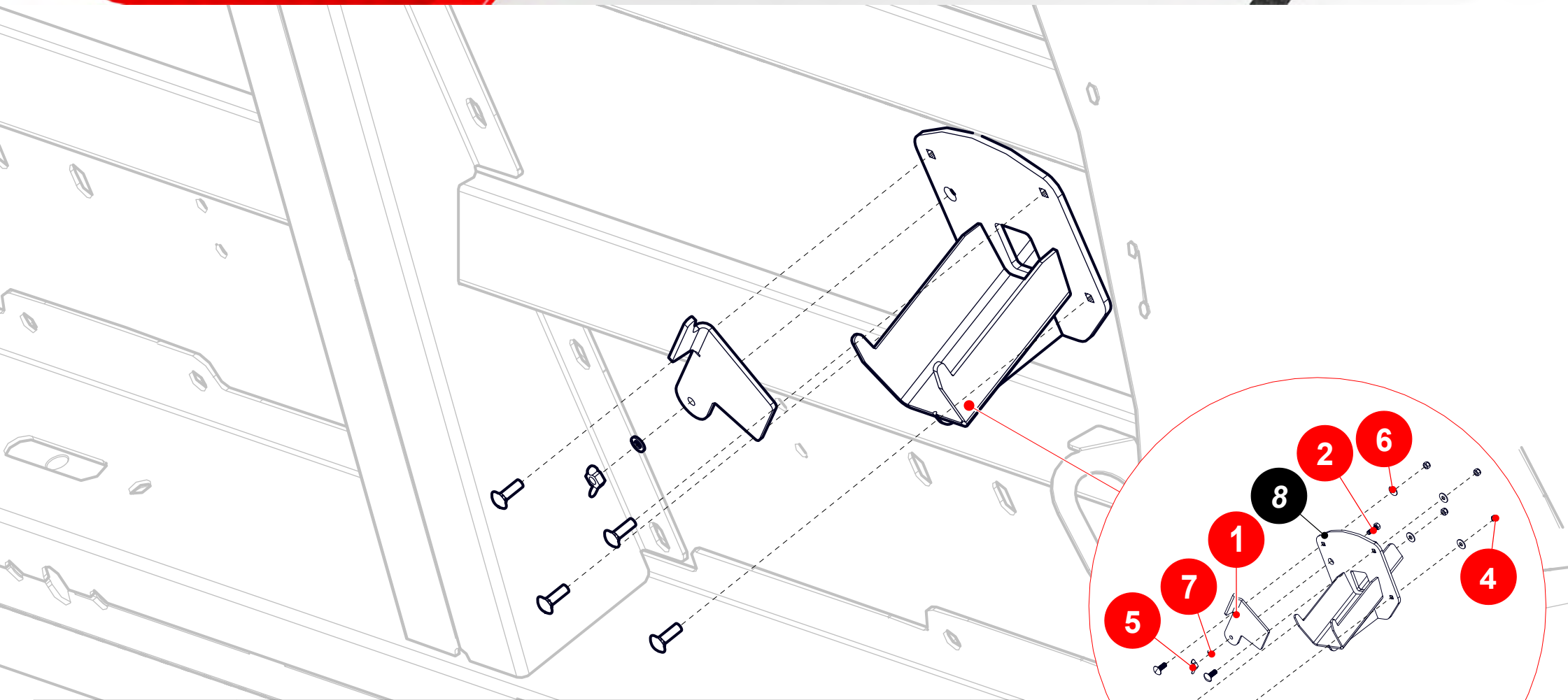

N°	PART	DESCRIPTION	QTY
1	29.42.33315	-- Cap	1
2	98.002.079025	- Hex. Head Screw 5/16" X 1"	1
3	98.190.079025	- Round head square neck TORN.C/RED.CUELLO CUAD.G5 5/16" X 7/8" RW	4
4	98.304.151079	- Lock Nut W 5/16"	4
5	98.307.111079	- Wing	1
6	98.309.100079	- Flat Washer 5/16"	4
7	98.310.100079	- Grower Washer 5/16"	1
8	29.39.33310	-- Grain Sample	1

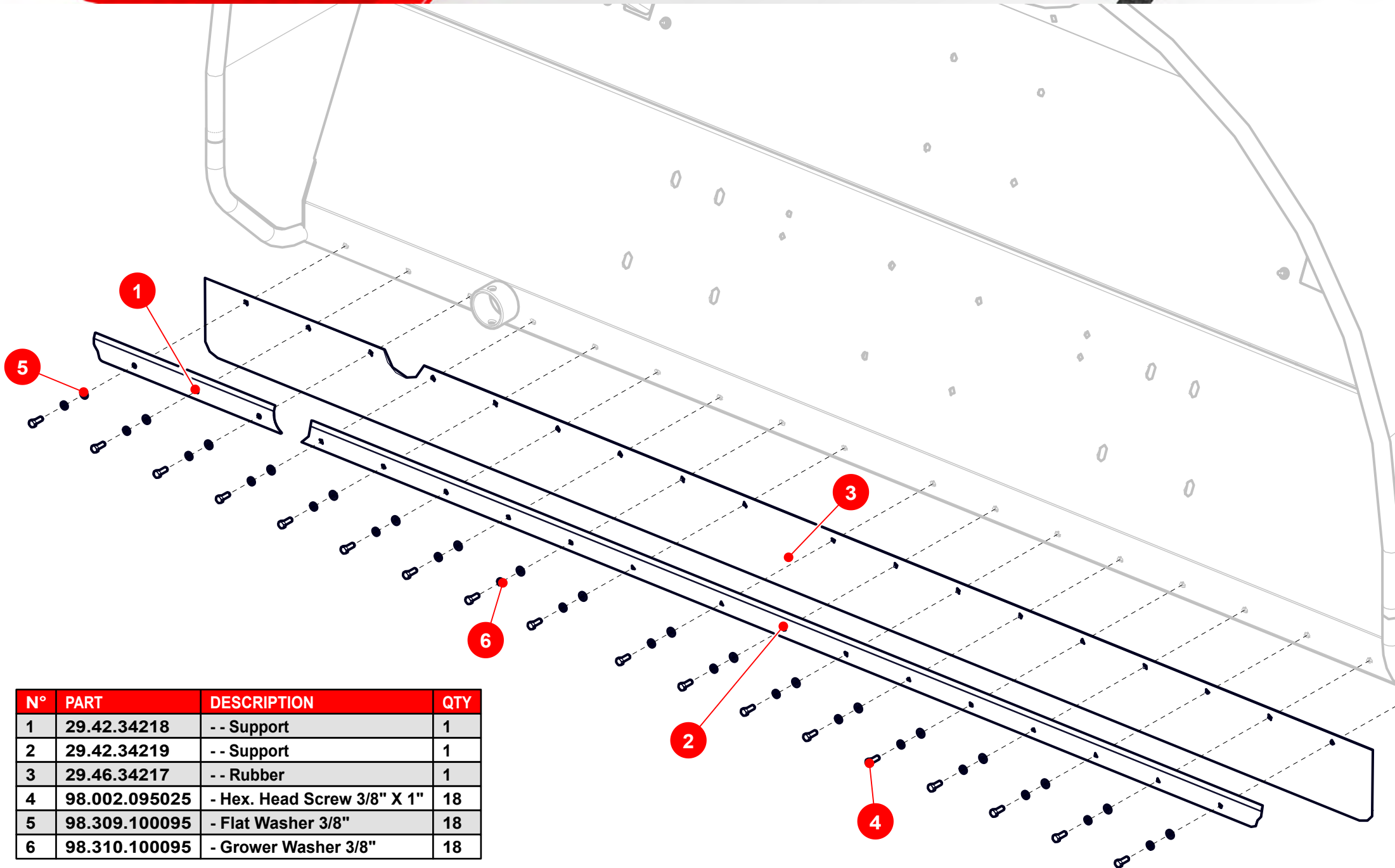

N°	PART	DESCRIPTION	QTY
1	29.42.34218	-- Support	1
2	29.42.34219	-- Support	1
3	29.46.34217	-- Rubber	1
4	98.002.095025	- Hex. Head Screw 3/8" X 1"	18
5	98.309.100095	- Flat Washer 3/8"	18
6	98.310.100095	- Grower Washer 3/8"	18

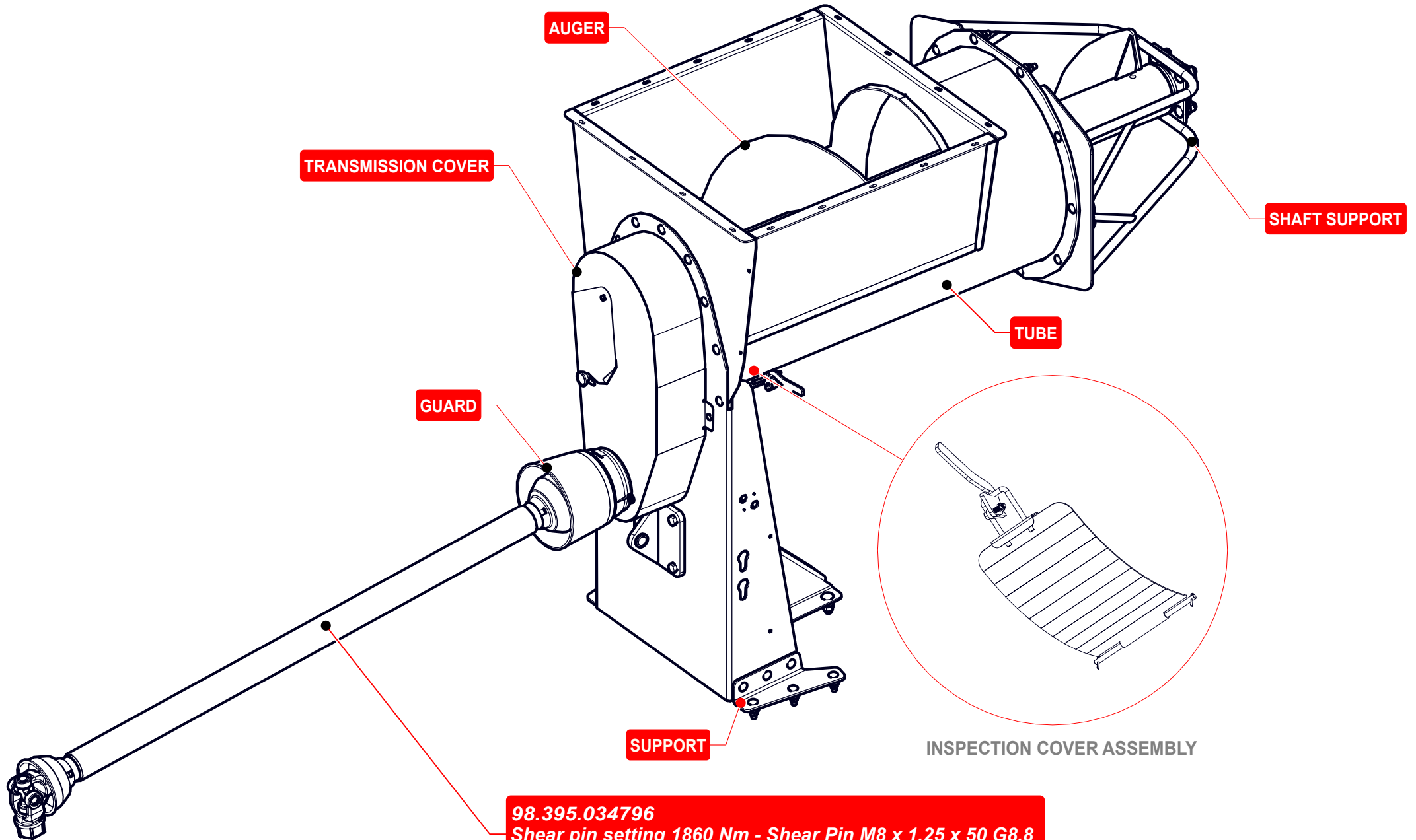

98.395.034796
Shear pin setting 1860 Nm - Shear Pin M8 x 1.25 x 50 G8.8
(MICRON/EDMA CARDAN SHAFT)

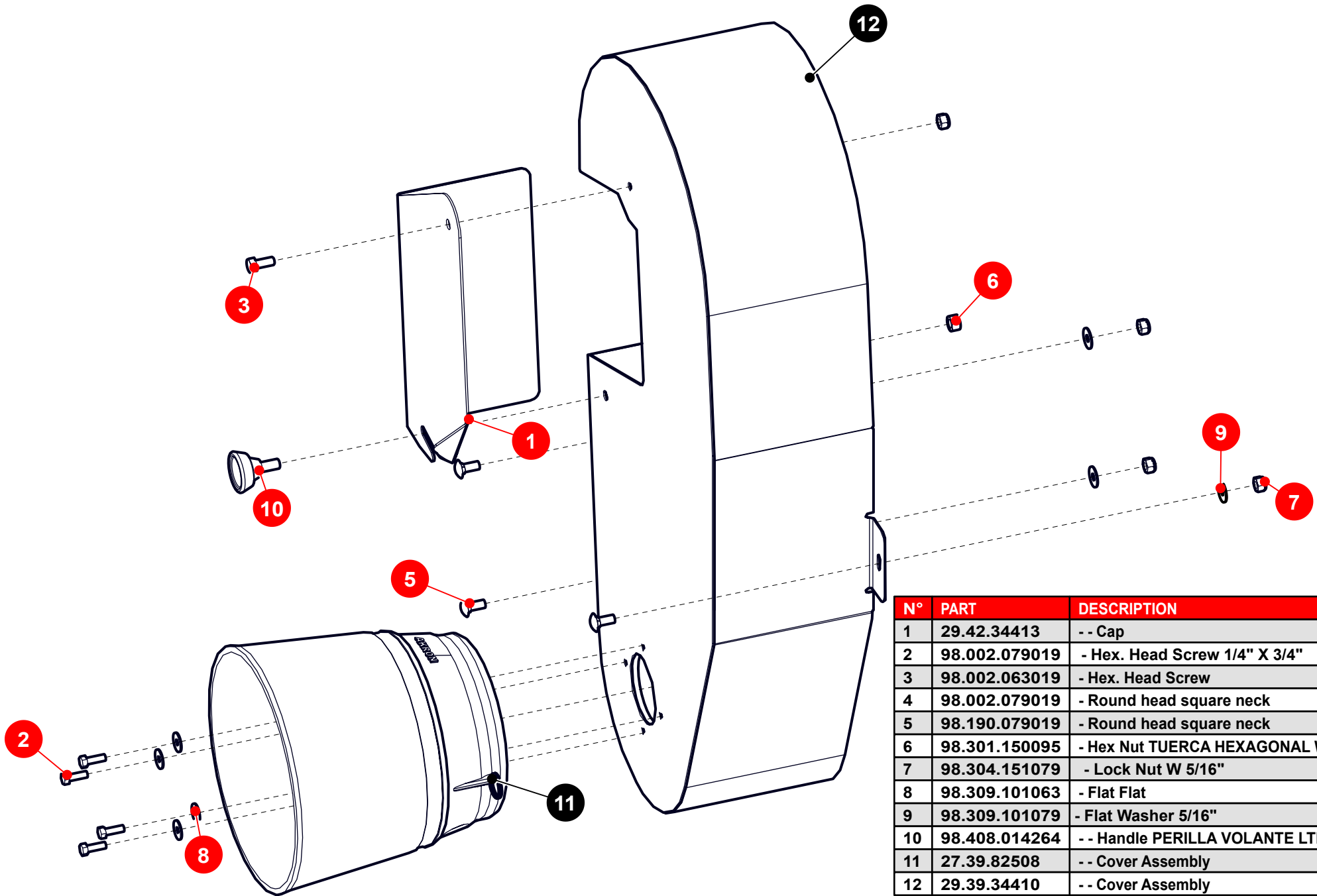

N°	PART	DESCRIPTION	QTY
1	29.42.34413	-- Cap	1
2	98.002.079019	- Hex. Head Screw 1/4" X 3/4"	4
3	98.002.063019	- Hex. Head Screw	1
4	98.002.079019	- Round head square neck	2
5	98.190.079019	- Round head square neck	1
6	98.301.150095	- Hex Nut TUERCA HEXAGONAL W3/8" x 16	1
7	98.304.151079	- Lock Nut W 5/16"	4
8	98.309.101063	- Flat Flat	4
9	98.309.101079	- Flat Washer 5/16"	3
10	98.408.014264	-- Handle PERILLA VOLANTE LTD 875 1833	1
11	27.39.82508	-- Cover Assembly	1
12	29.39.34410	-- Cover Assembly	1

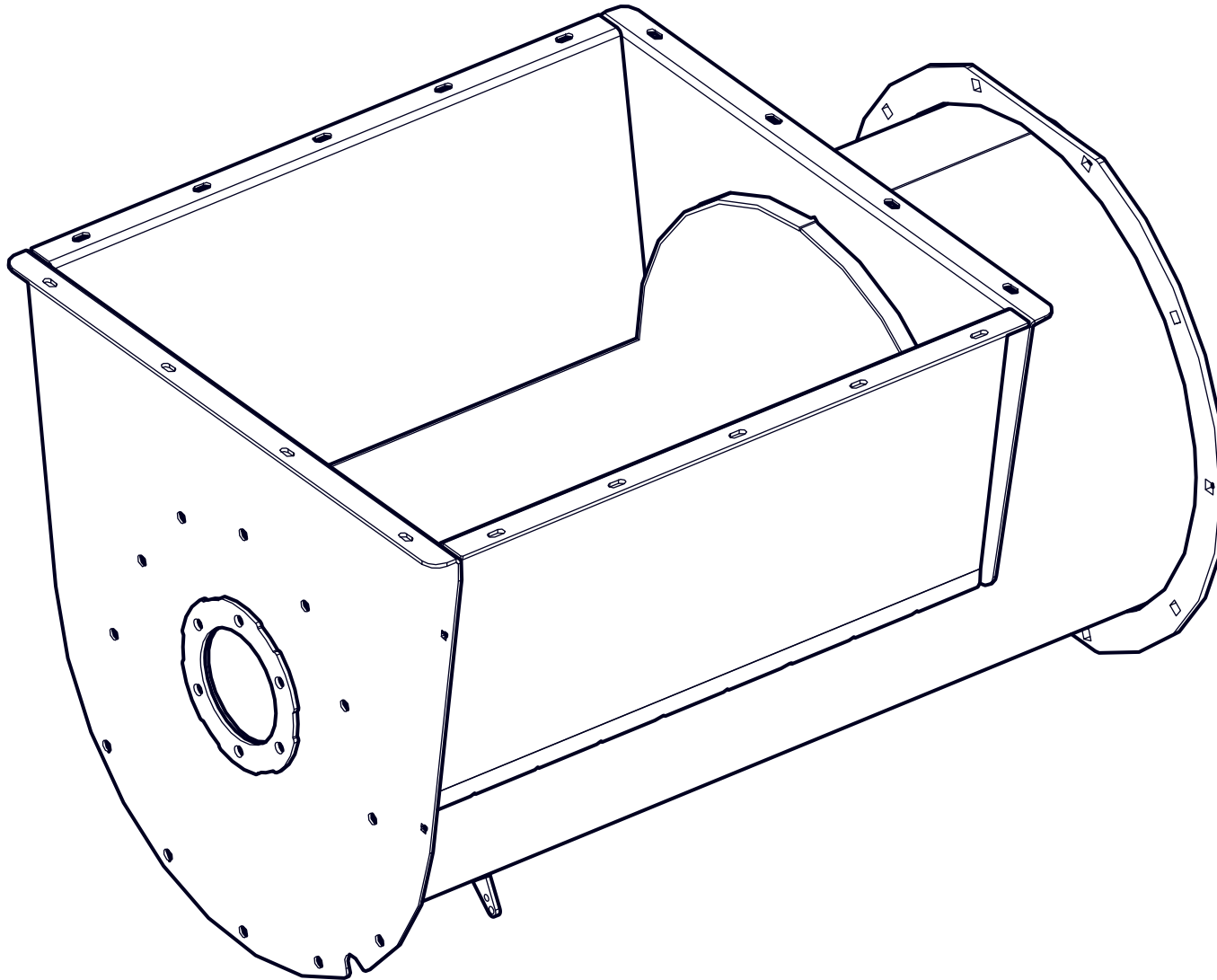

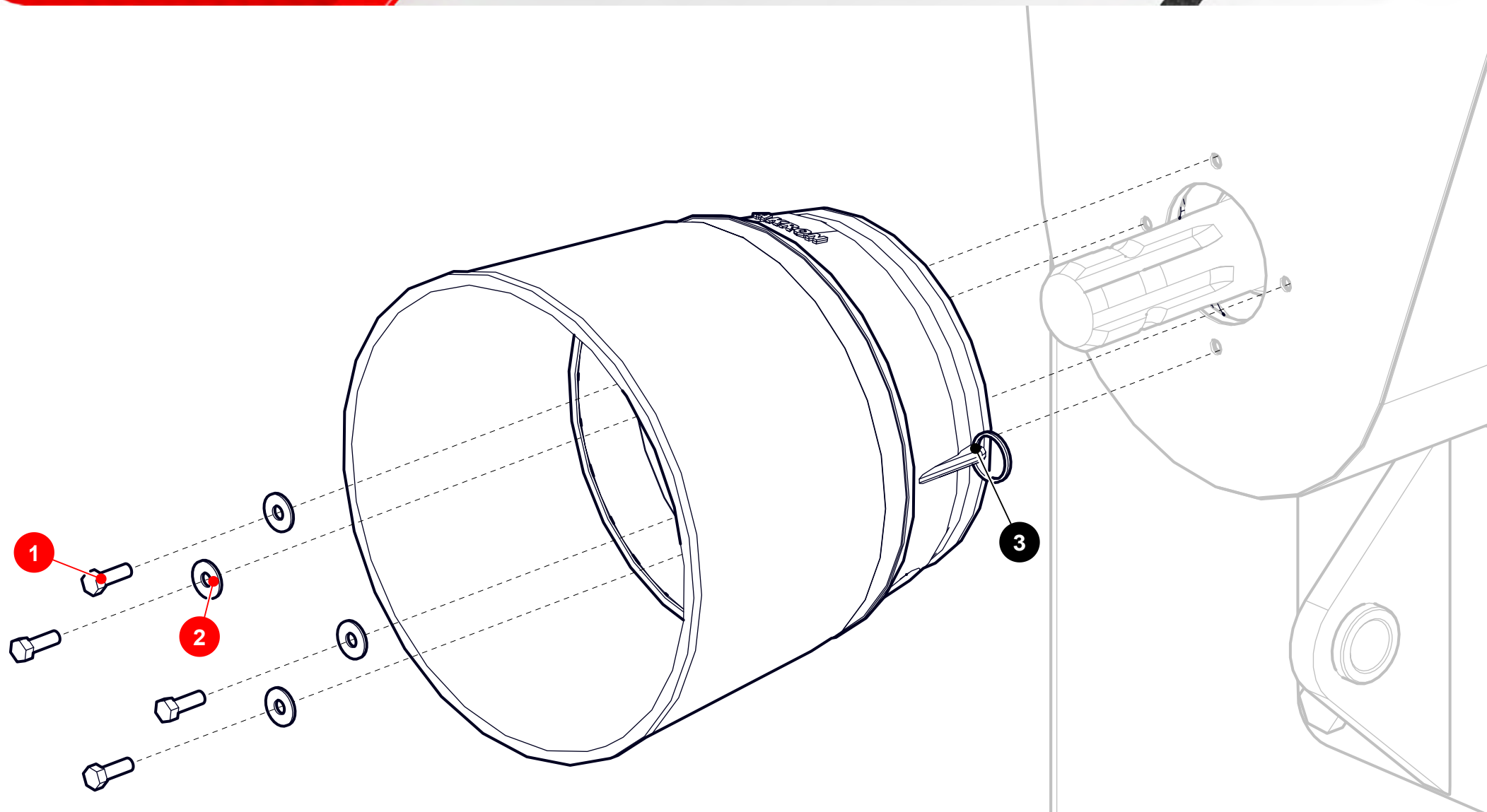

N°	PART	DESCRIPTION	QTY
1	98.002.063019	- Hex. Head Screw 1/4" X 3/4"	4
2	98.309.101063	- Flat Flat	4
3	27.39.82508	-- Cover Assembly	1

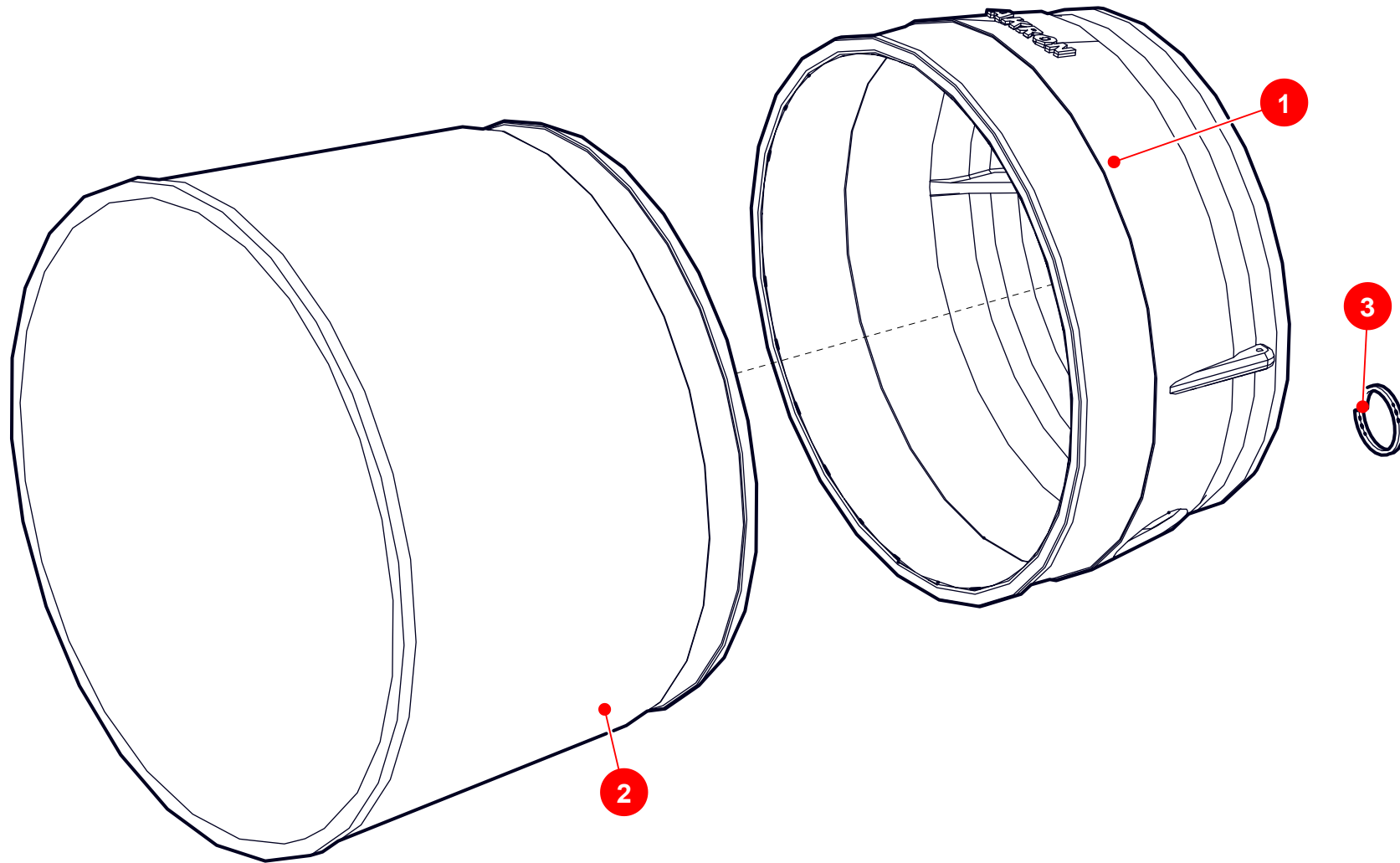

N°	PART	DESCRIPTION	QTY
1	27.56.82509	-- Cover support	1
2	27.56.82510	- Assembly Cover support	1
3	98.328.014220	-- Ring	1

N°	PART	DESCRIPTION	QTY
1	29.42.25993	-- Handle	1
2	29.43.25973	-- Shaft	1
3	29.43.25994	-- U-Bolt	1
4	98.002.079025	- Hex. Head Screw 5/16" X 1"	2
5	98.304.151079	- Lock Nut W 5/16"	4
6	98.311.100079	- Chamfered Washer 5/16"	2
7	98.334.030030	-- Split pin PASADOR DE ALETAS Ø N°10 X 30 mm	2
8	29.39.34335	-- Inspection Gate	1

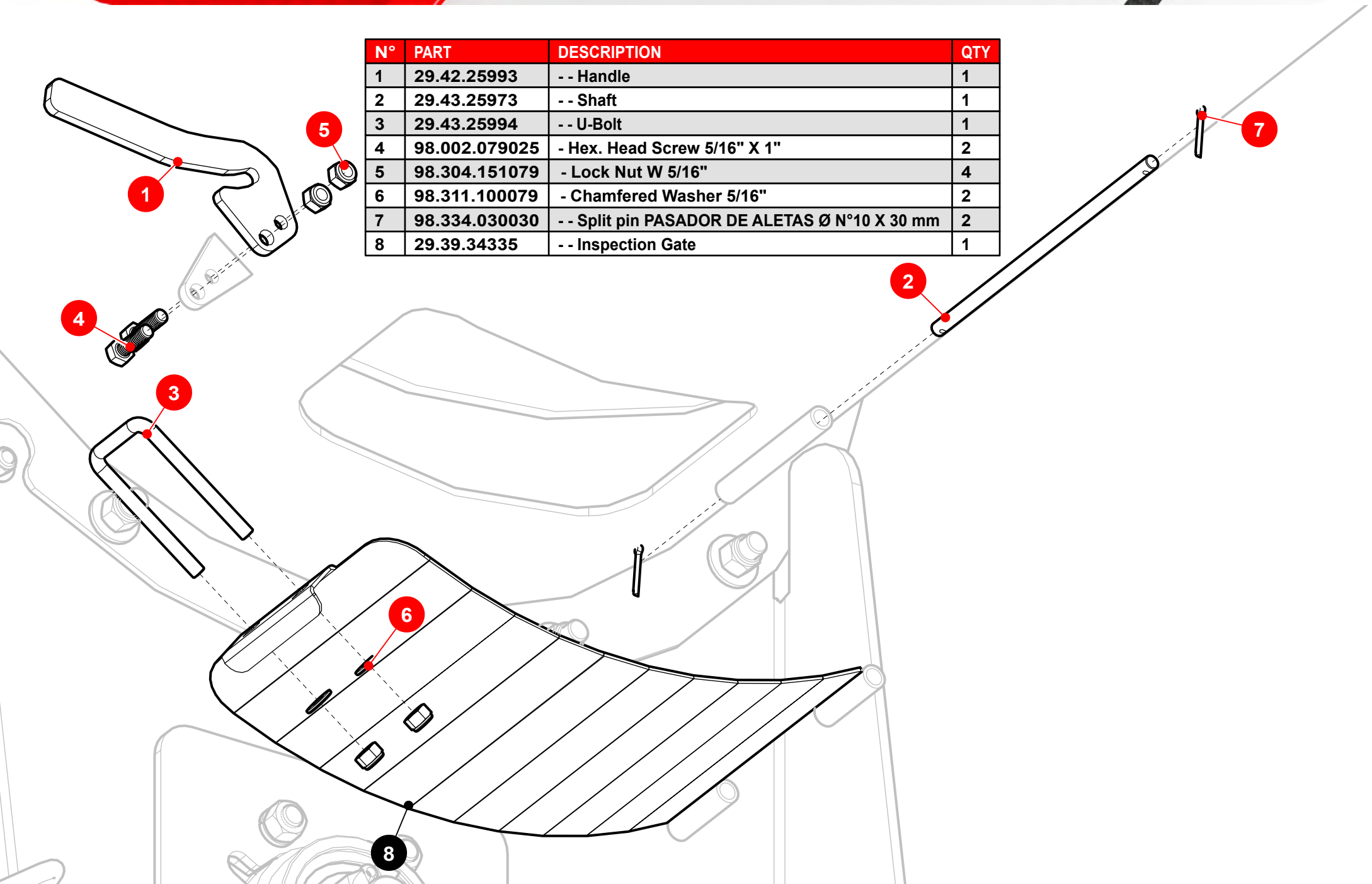

N°	PART	DESCRIPTION	QTY
1	29.29.34410	--Cover Assembly	1

COVER ASSEMBLY

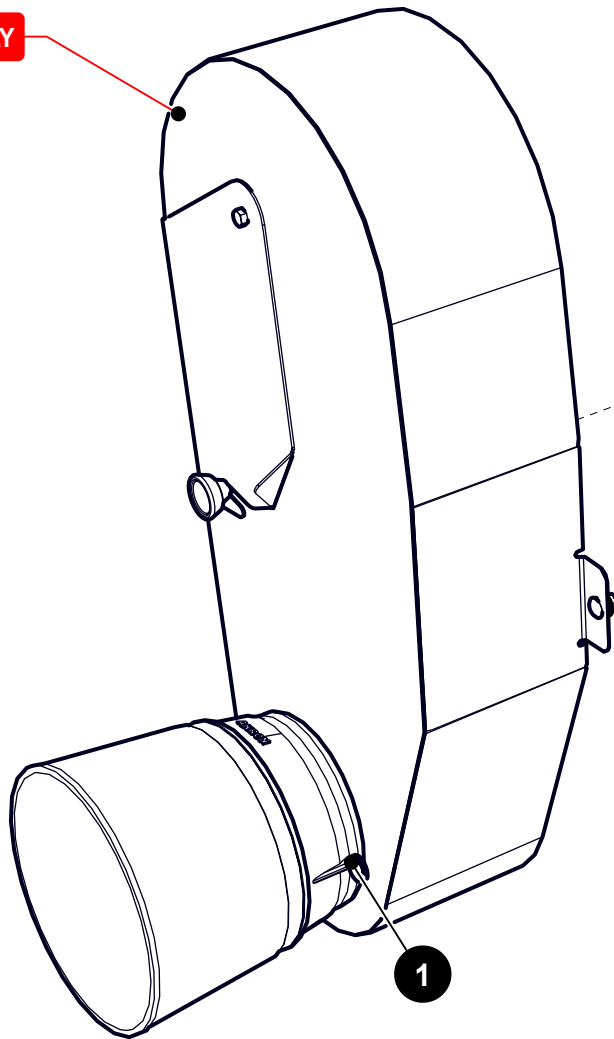

TRANSMISSION ASSEMBLY

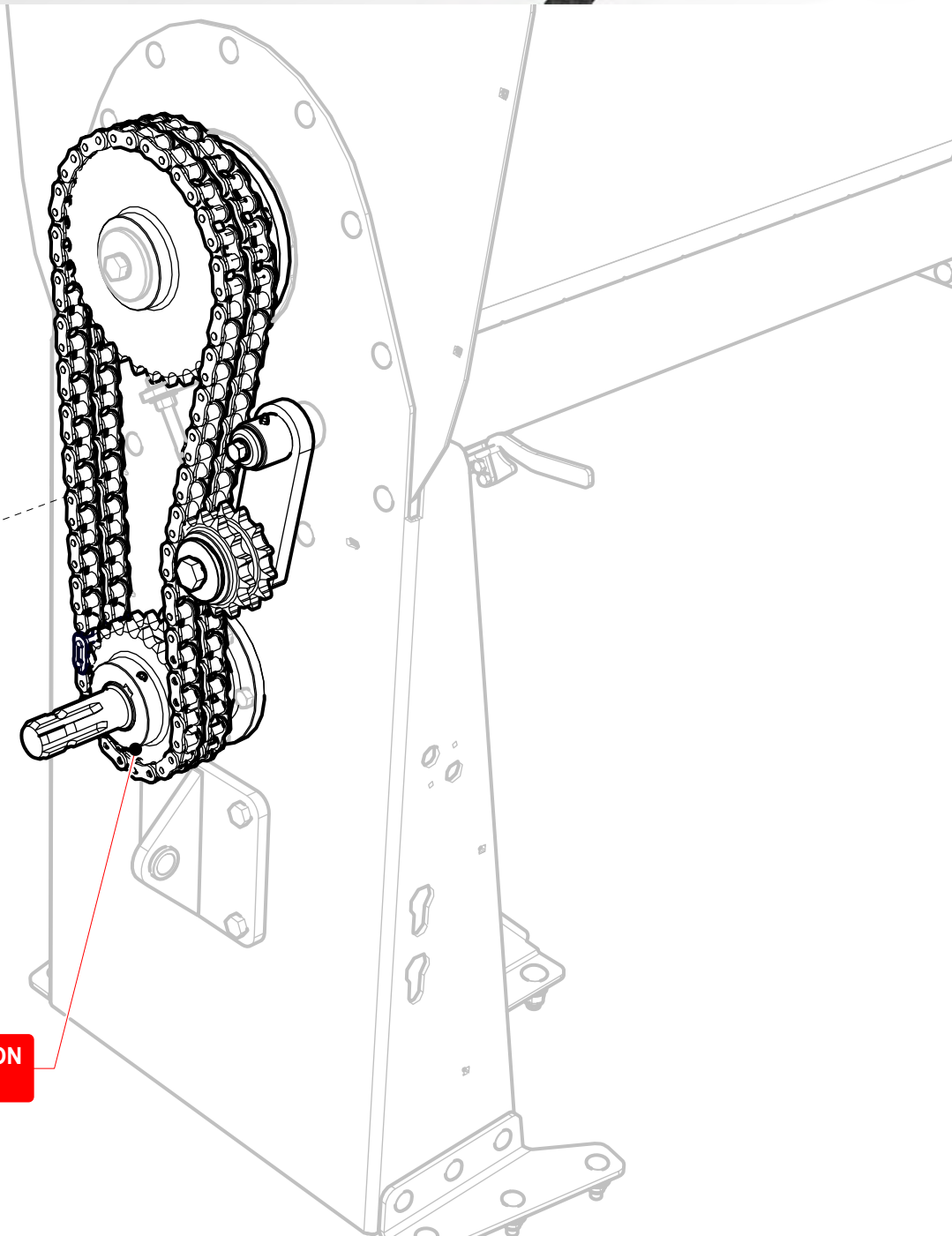

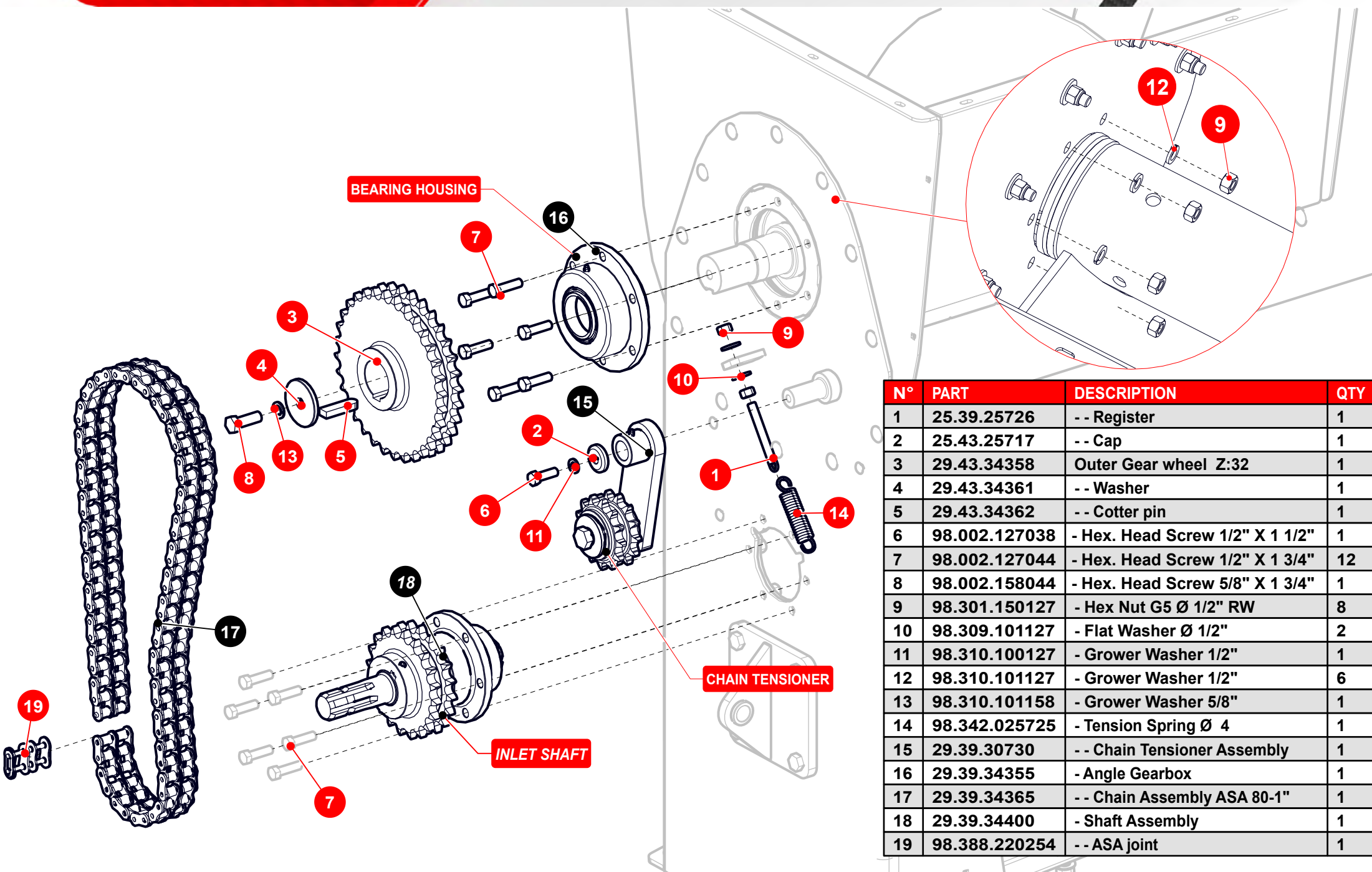

N°	PART	DESCRIPTION	QTY
1	25.39.25726	-- Register	1
2	25.43.25717	-- Cap	1
3	29.43.34358	Outer Gear wheel Z:32	1
4	29.43.34361	-- Washer	1
5	29.43.34362	-- Cotter pin	1
6	98.002.127038	- Hex. Head Screw 1/2" X 1 1/2"	1
7	98.002.127044	- Hex. Head Screw 1/2" X 1 3/4"	12
8	98.002.158044	- Hex. Head Screw 5/8" X 1 3/4"	1
9	98.301.150127	- Hex Nut G5 Ø 1/2" RW	8
10	98.309.101127	- Flat Washer Ø 1/2"	2
11	98.310.100127	- Grower Washer 1/2"	1
12	98.310.101127	- Grower Washer 1/2"	6
13	98.310.101158	- Grower Washer 5/8"	1
14	98.342.025725	- Tension Spring Ø 4	1
15	29.39.30730	-- Chain Tensioner Assembly	1
16	29.39.34355	- Angle Gearbox	1
17	29.39.34365	-- Chain Assembly ASA 80-1"	1
18	29.39.34400	- Shaft Assembly	1
19	98.388.220254	-- ASA joint	1

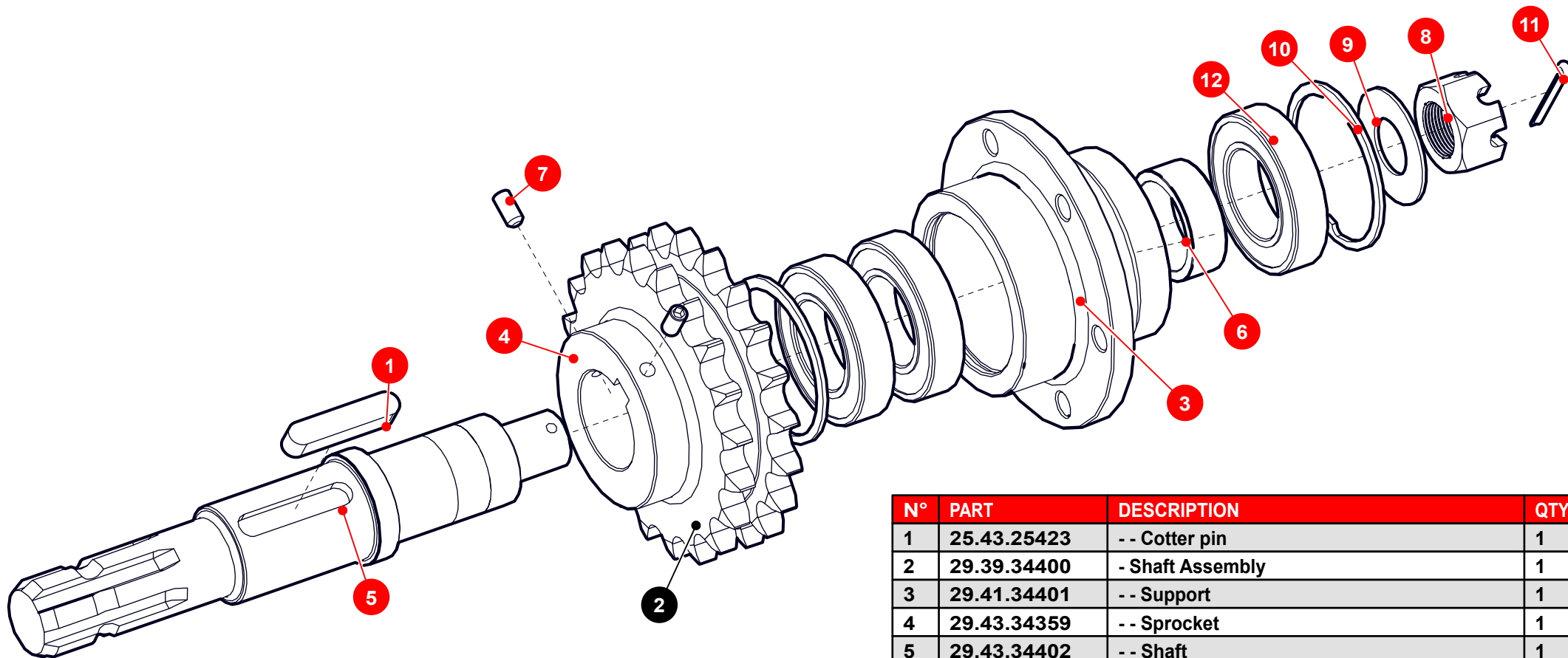

N°	PART	DESCRIPTION	QTY
1	25.43.25423	-- Cotter pin	1
2	29.39.34400	- Shaft Assembly	1
3	29.41.34401	-- Support	1
4	29.43.34359	-- Sprocket	1
5	29.43.34402	-- Shaft	1
6	29.43.34403	-- Bushing	1
7	98.077.095019	- Flush head allen Screw 3/8" X 3/4"	2
8	98.303.311317	- Castle Nut NF 1 1/4"	1
9	98.309.100317	- Flat Washer 1 1/4"	1
10	98.322.000900	- Int. Retaining ring	2
11	98.334.050060	-- Split pin PASADOR DEALETA Ø 5 X 60 mm	1
12	98.705.507750	-- Bearing RODAMIENTO N° 6210-2RS SKF	3

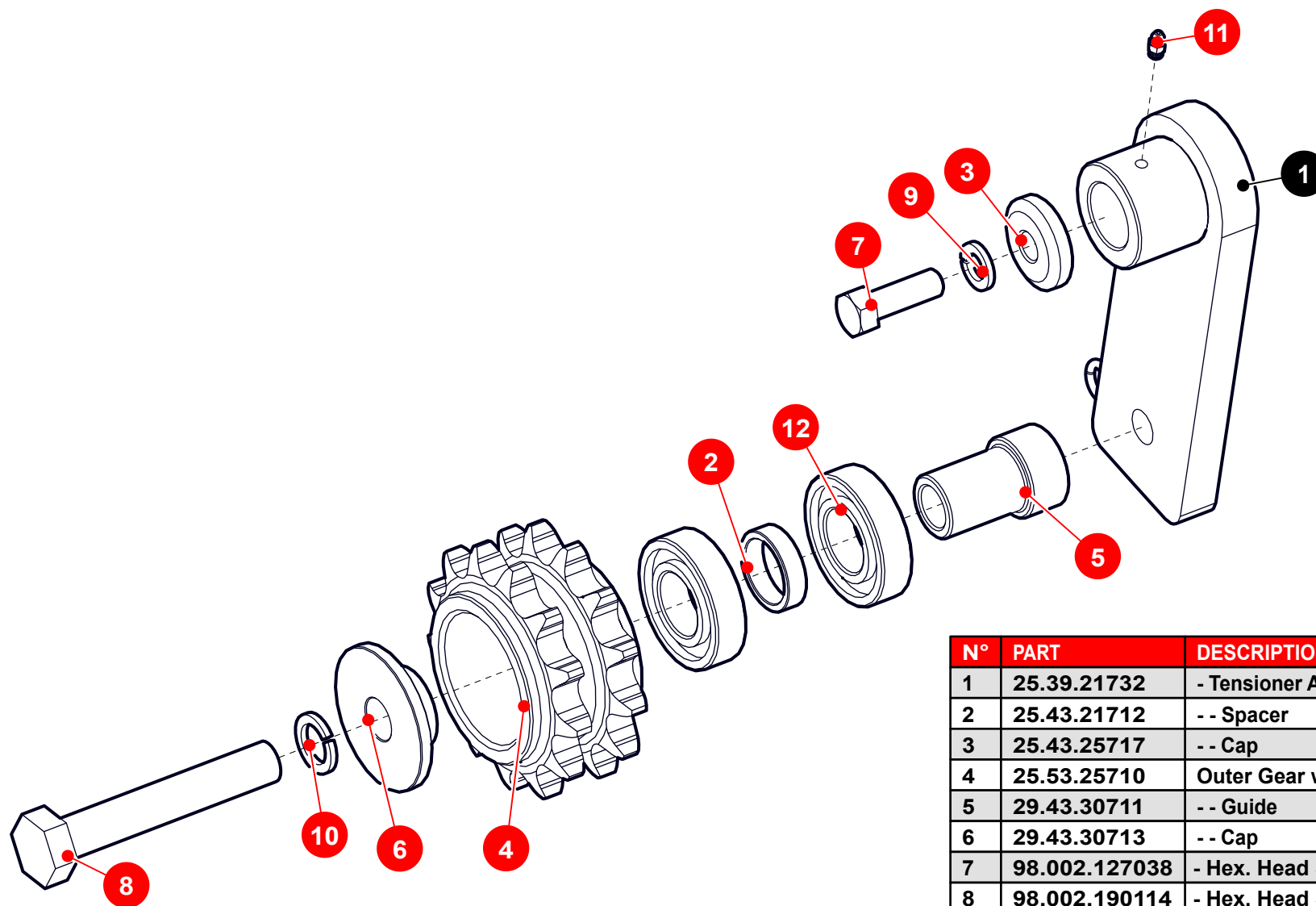

N°	PART	DESCRIPTION	QTY
1	25.39.21732	- Tensioner Assembly	1
2	25.43.21712	-- Spacer	1
3	25.43.25717	-- Cap	1
4	25.53.25710	Outer Gear wheel Z:13	1
5	29.43.30711	-- Guide	1
6	29.43.30713	-- Cap	1
7	98.002.127038	- Hex. Head Screw 1/2" X 1 1/2"	1
8	98.002.190114	- Hex. Head Screw 3/4" X 4 1/2"	1
9	98.310.100127	- Grower Washer 1/2"	1
10	98.310.100190	- Grower Grower	1
11	98.460.300063	Straight Grease Fitting 1/4" NF	1
12	98.705.206530	-- Bearing BOLILLERO 6206 2RS	2

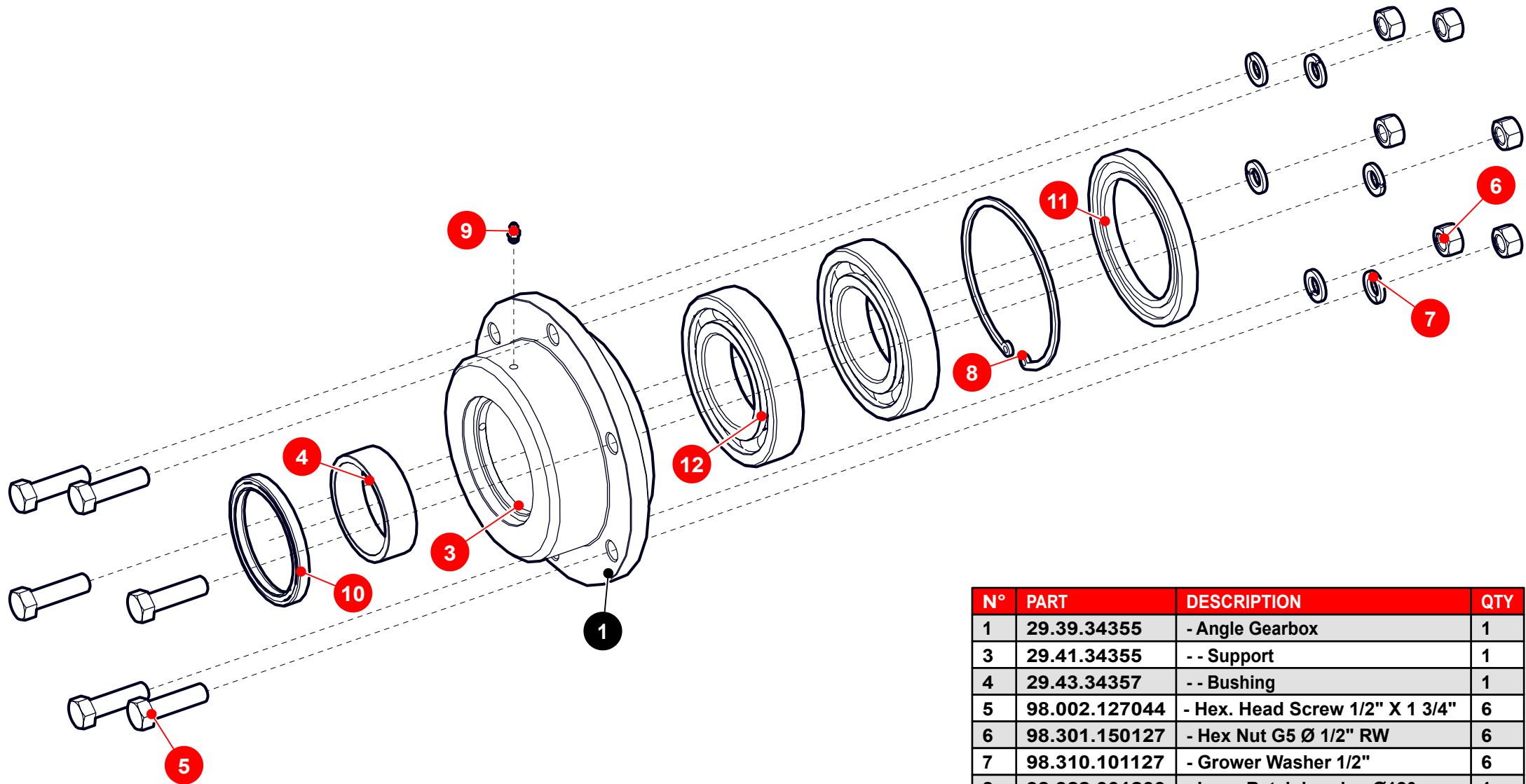

N°	PART	DESCRIPTION	QTY
1	29.39.34355	- Angle Gearbox	1
3	29.41.34355	- - Support	1
4	29.43.34357	- - Bushing	1
5	98.002.127044	- Hex. Head Screw 1/2" X 1 3/4"	6
6	98.301.150127	- Hex Nut G5 Ø 1/2" RW	6
7	98.310.101127	- Grower Washer 1/2"	6
8	98.322.001200	- Inner Retaining ring Ø120	1
9	98.460.300063	Straight Grease Fitting 1/4" NF	1
10	98.610.345285	- DBH Oil Seal 5285 - Lx	1
11	98.611.178084	- SAV Oil Seal 10279	1
12	98.713.134357	- - Bearing	2

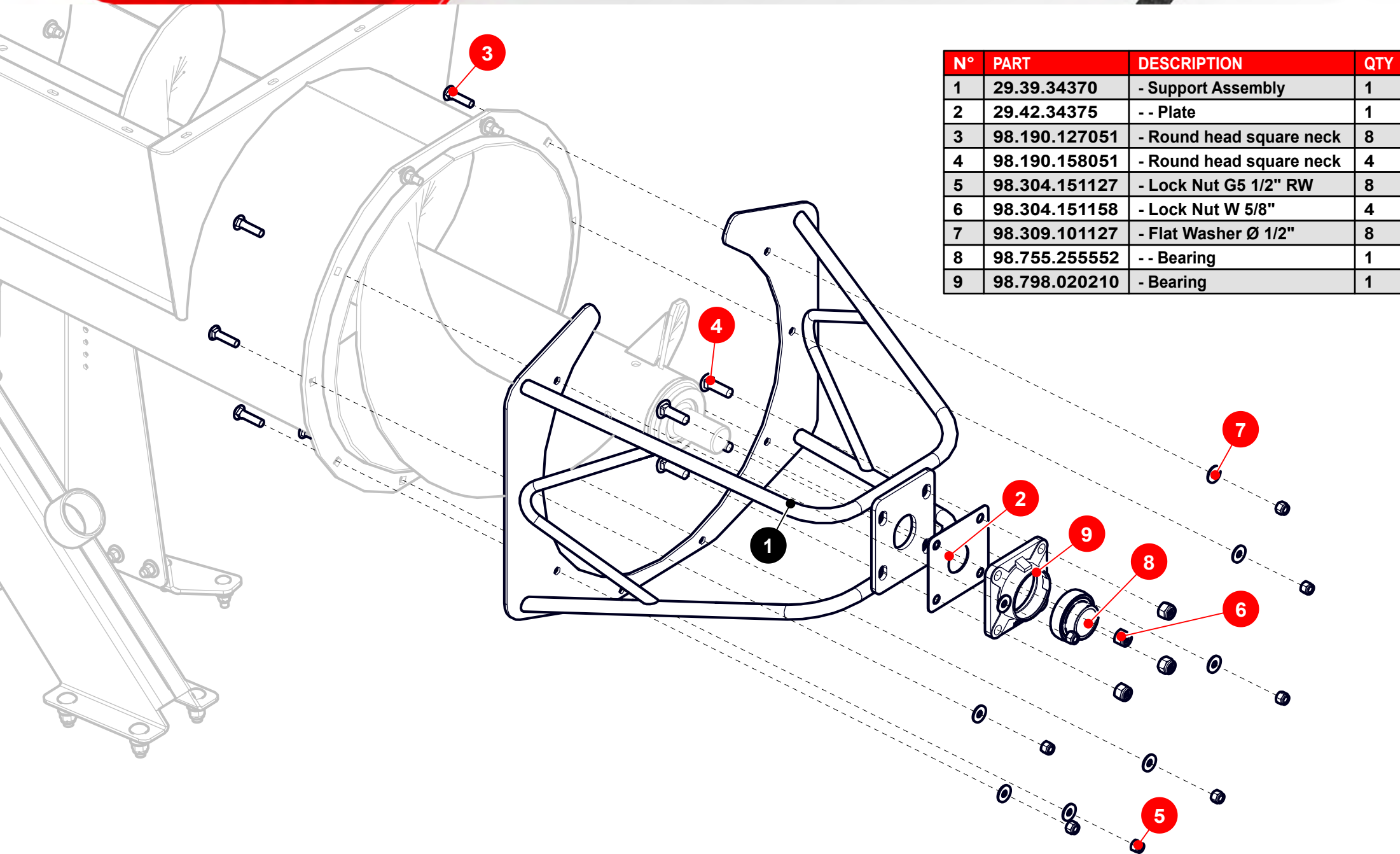

N°	PART	DESCRIPTION	QTY
1	29.39.34370	- Support Assembly	1
2	29.42.34375	- - Plate	1
3	98.190.127051	- Round head square neck	8
4	98.190.158051	- Round head square neck	4
5	98.304.151127	- Lock Nut G5 1/2" RW	8
6	98.304.151158	- Lock Nut W 5/8"	4
7	98.309.101127	- Flat Washer Ø 1/2"	8
8	98.755.255552	- - Bearing	1
9	98.798.020210	- Bearing	1

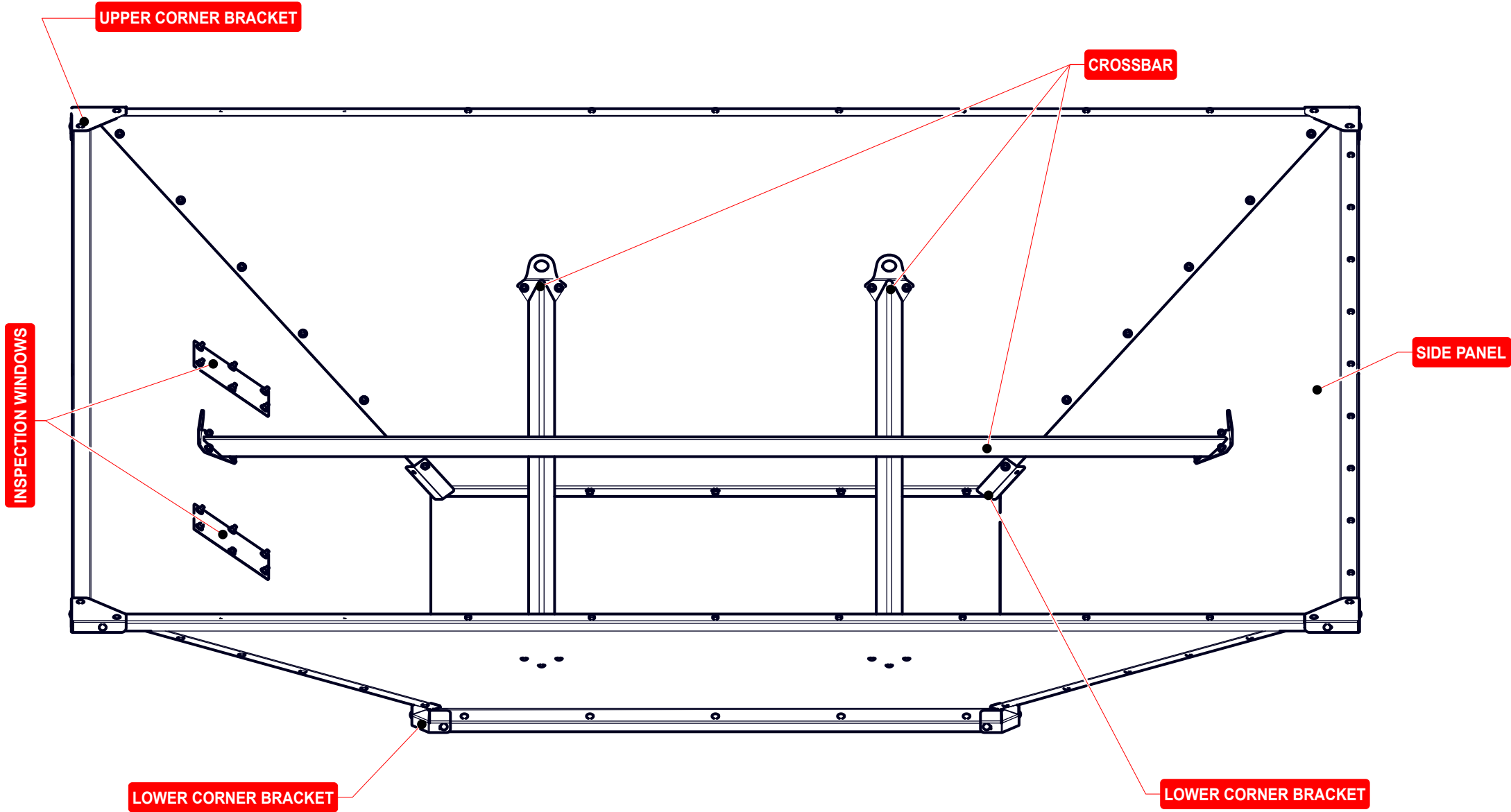

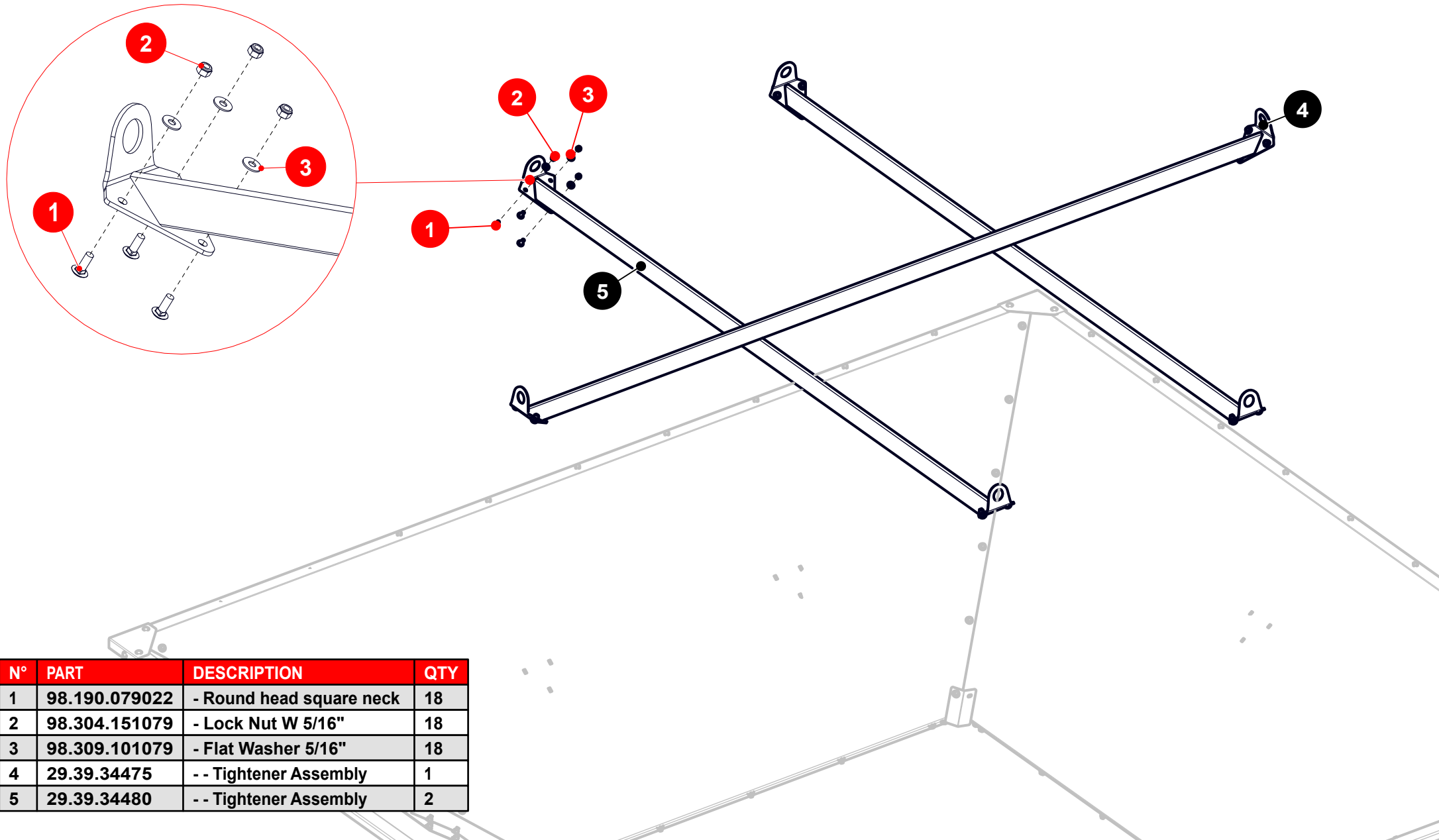

N°	PART	DESCRIPTION	QTY
1	98.190.079022	- Round head square neck	18
2	98.304.151079	- Lock Nut W 5/16"	18
3	98.309.101079	- Flat Washer 5/16"	18
4	29.39.34475	-- Tightener Assembly	1
5	29.39.34480	-- Tightener Assembly	2

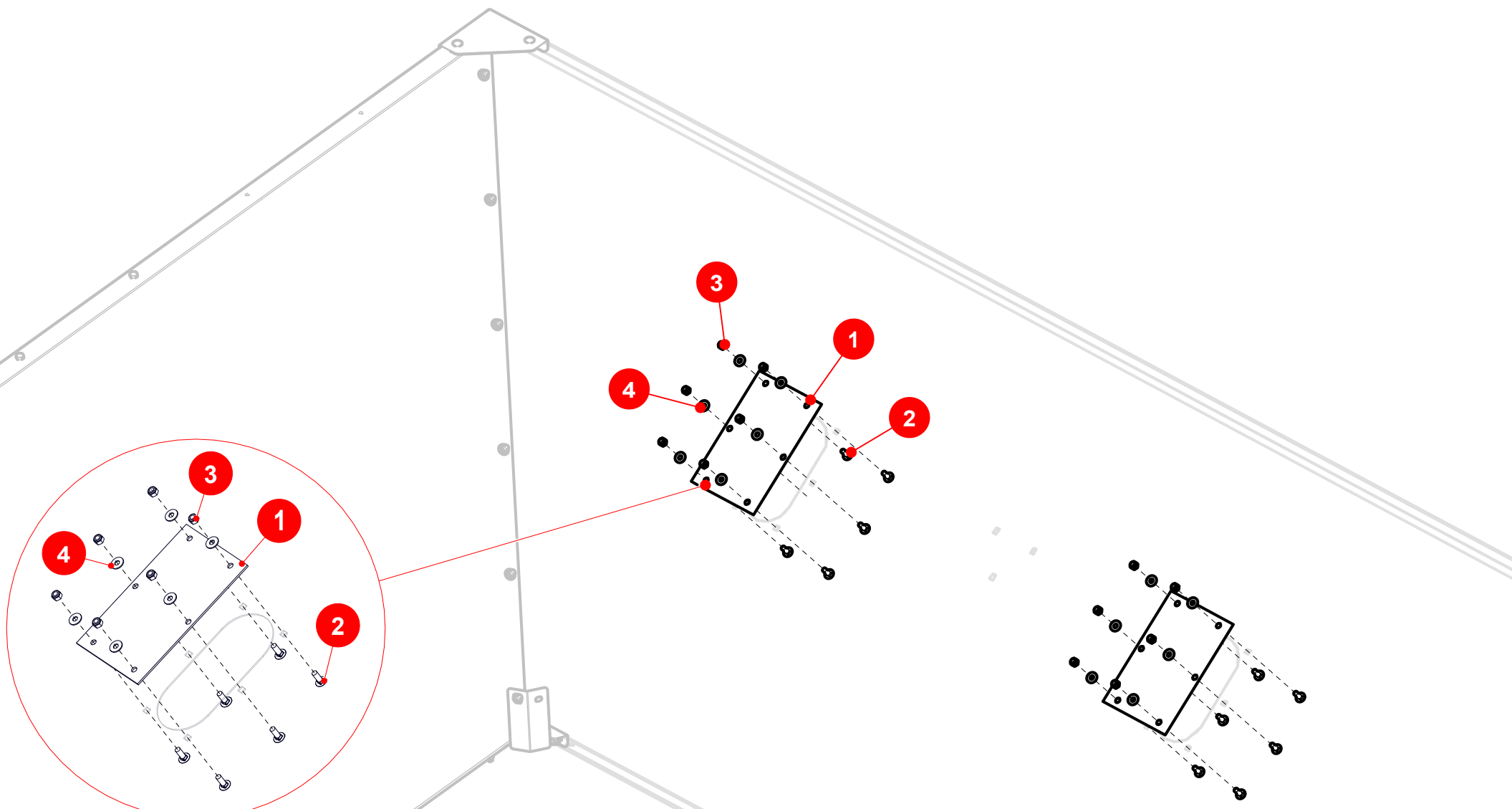

N°	PART	DESCRIPTION	QTY
1	29.46.27456	- Sight glass	2
2	98.190.079022	- Round head square neck	11
3	98.304.151079	- Lock Nut W 5/16"	12
4	98.309.101079	- Flat Washer 5/16"	12

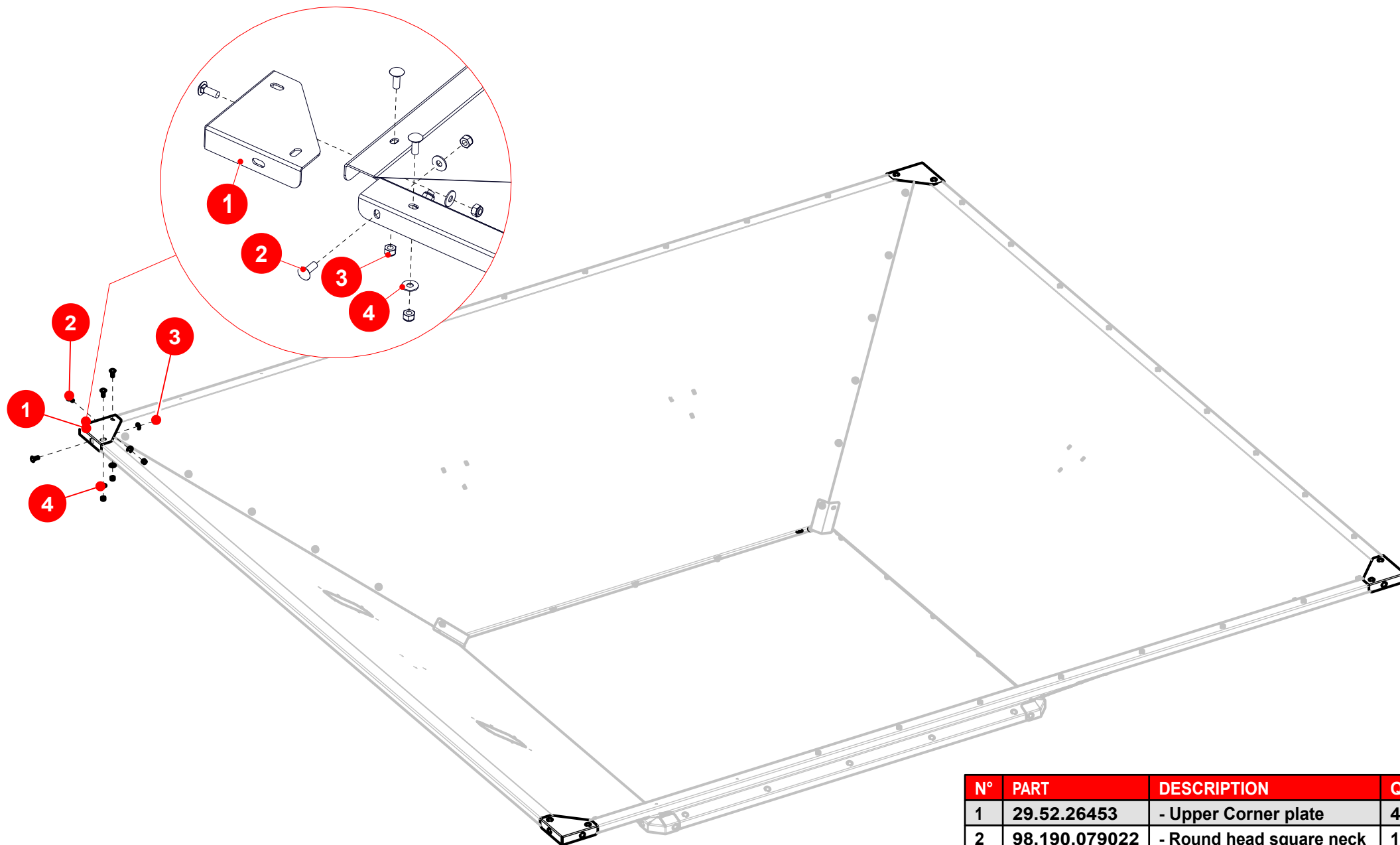

N°	PART	DESCRIPTION	QTY
1	29.52.26453	- Upper Corner plate	4
2	98.190.079022	- Round head square neck	16
3	98.304.151079	- Lock Nut W 5/16"	16
4	98.309.101079	- Flat Washer 5/16"	16

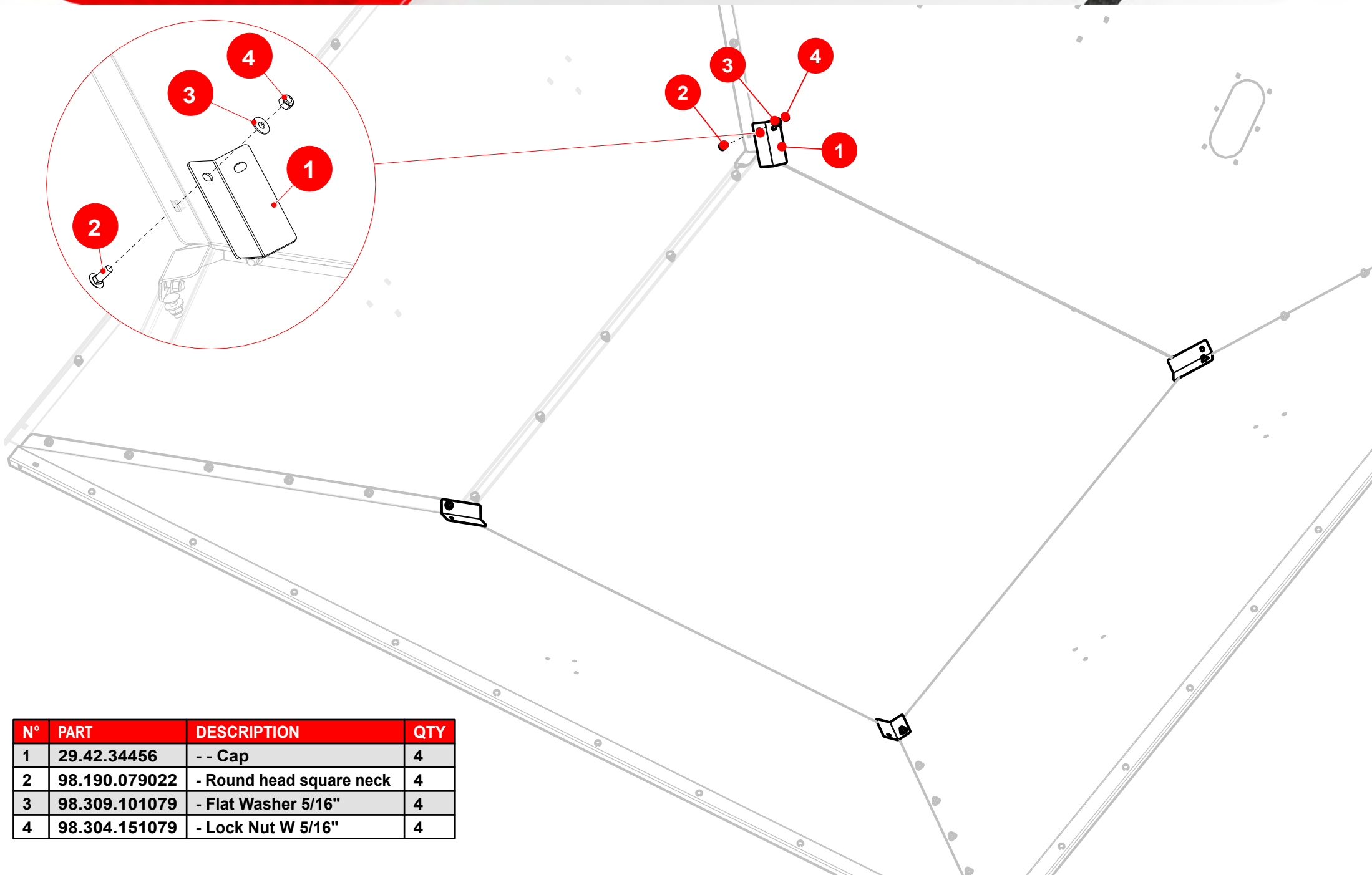

N°	PART	DESCRIPTION	QTY
1	29.42.34456	- - Cap	4
2	98.190.079022	- Round head square neck	4
3	98.309.101079	- Flat Washer 5/16"	4
4	98.304.151079	- Lock Nut W 5/16"	4

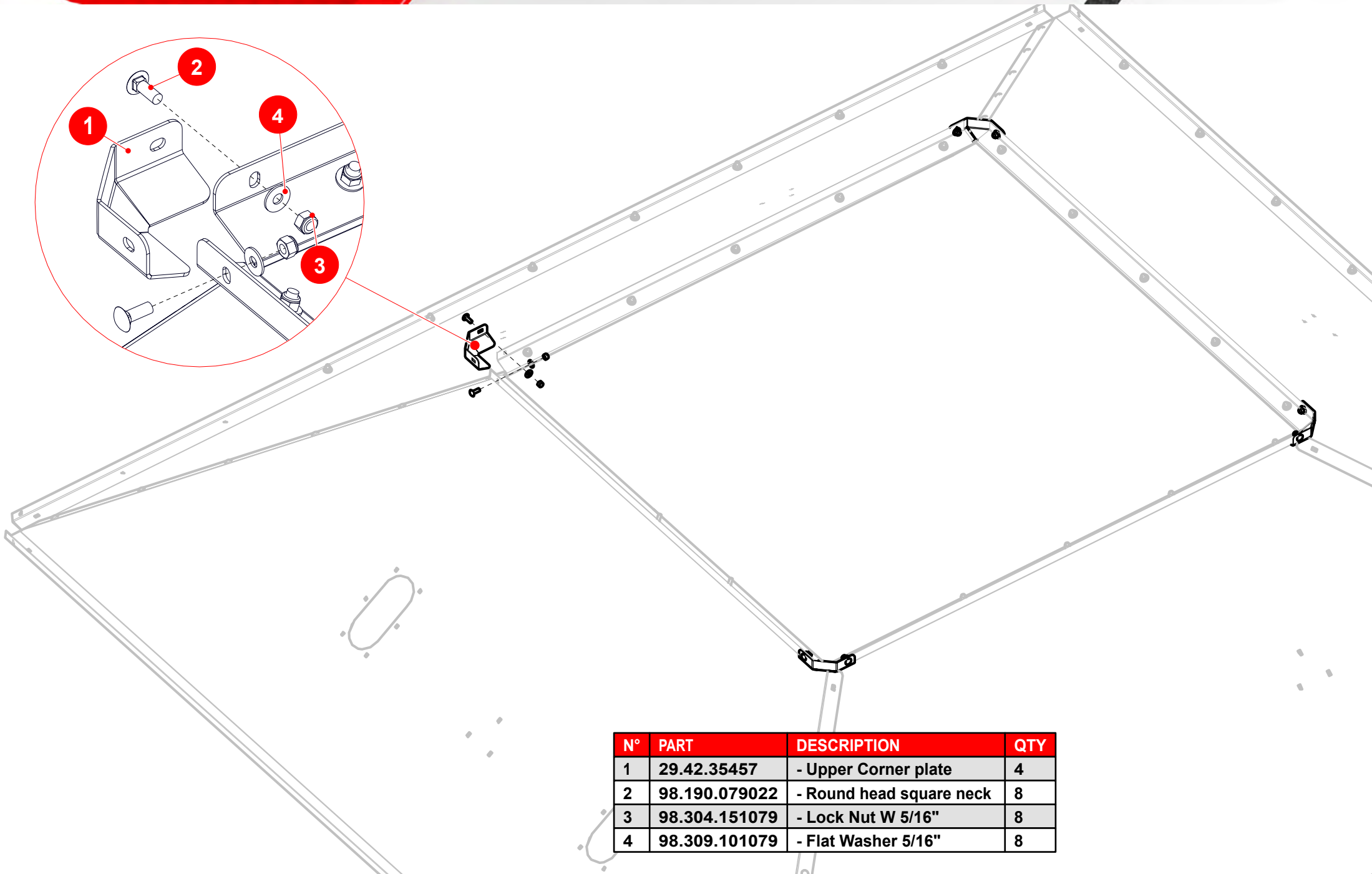

N°	PART	DESCRIPTION	QTY
1	29.42.35457	- Upper Corner plate	4
2	98.190.079022	- Round head square neck	8
3	98.304.151079	- Lock Nut W 5/16"	8
4	98.309.101079	- Flat Washer 5/16"	8

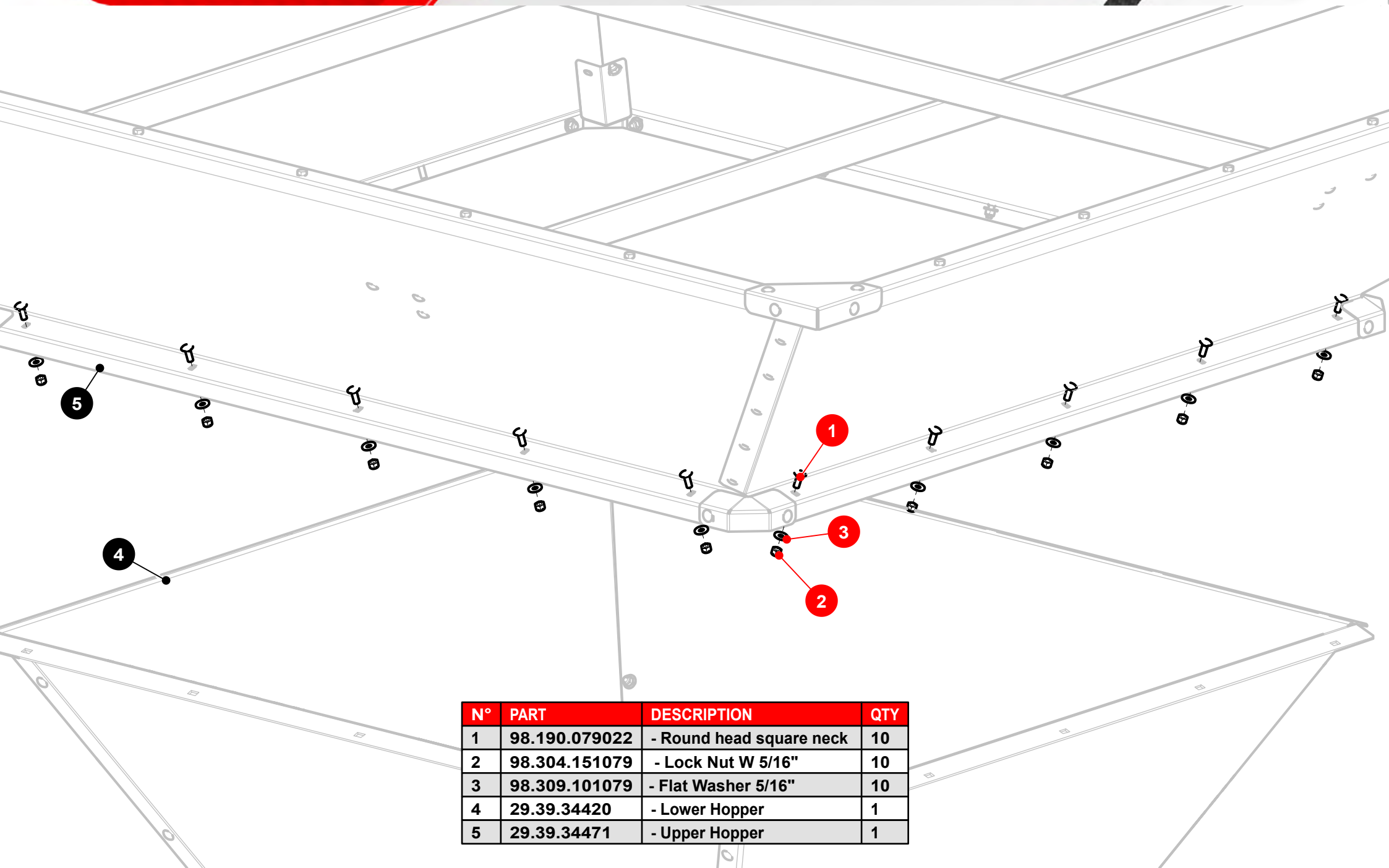

N°	PART	DESCRIPTION	QTY
1	98.190.079022	- Round head square neck	10
2	98.304.151079	- Lock Nut W 5/16"	10
3	98.309.101079	- Flat Washer 5/16"	10
4	29.39.34420	- Lower Hopper	1
5	29.39.34471	- Upper Hopper	1

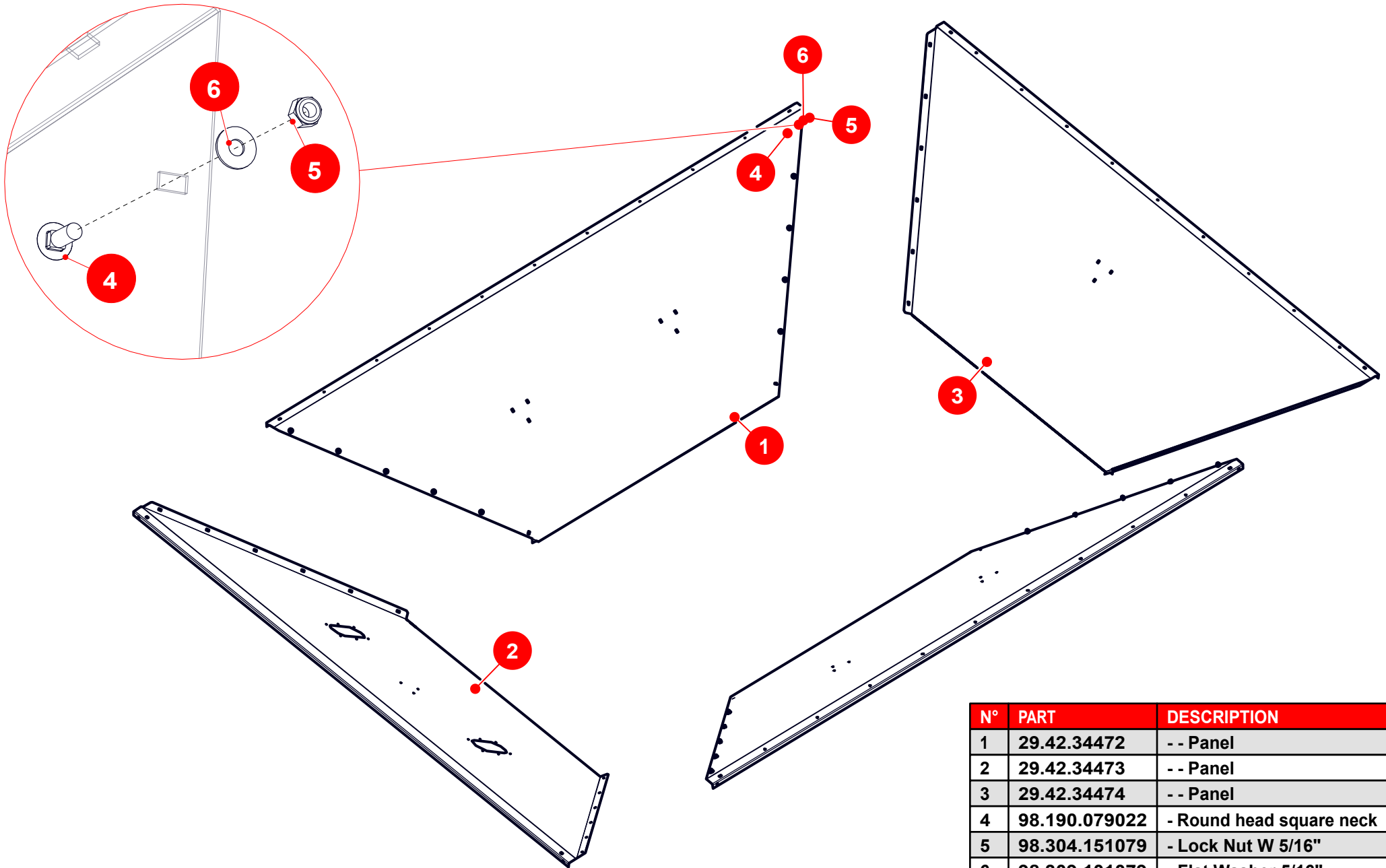

N°	PART	DESCRIPTION	QTY
1	29.42.34472	-- Panel	2
2	29.42.34473	-- Panel	1
3	29.42.34474	-- Panel	1
4	98.190.079022	- Round head square neck	20
5	98.304.151079	- Lock Nut W 5/16"	20
6	98.309.101079	- Flat Washer 5/16"	20

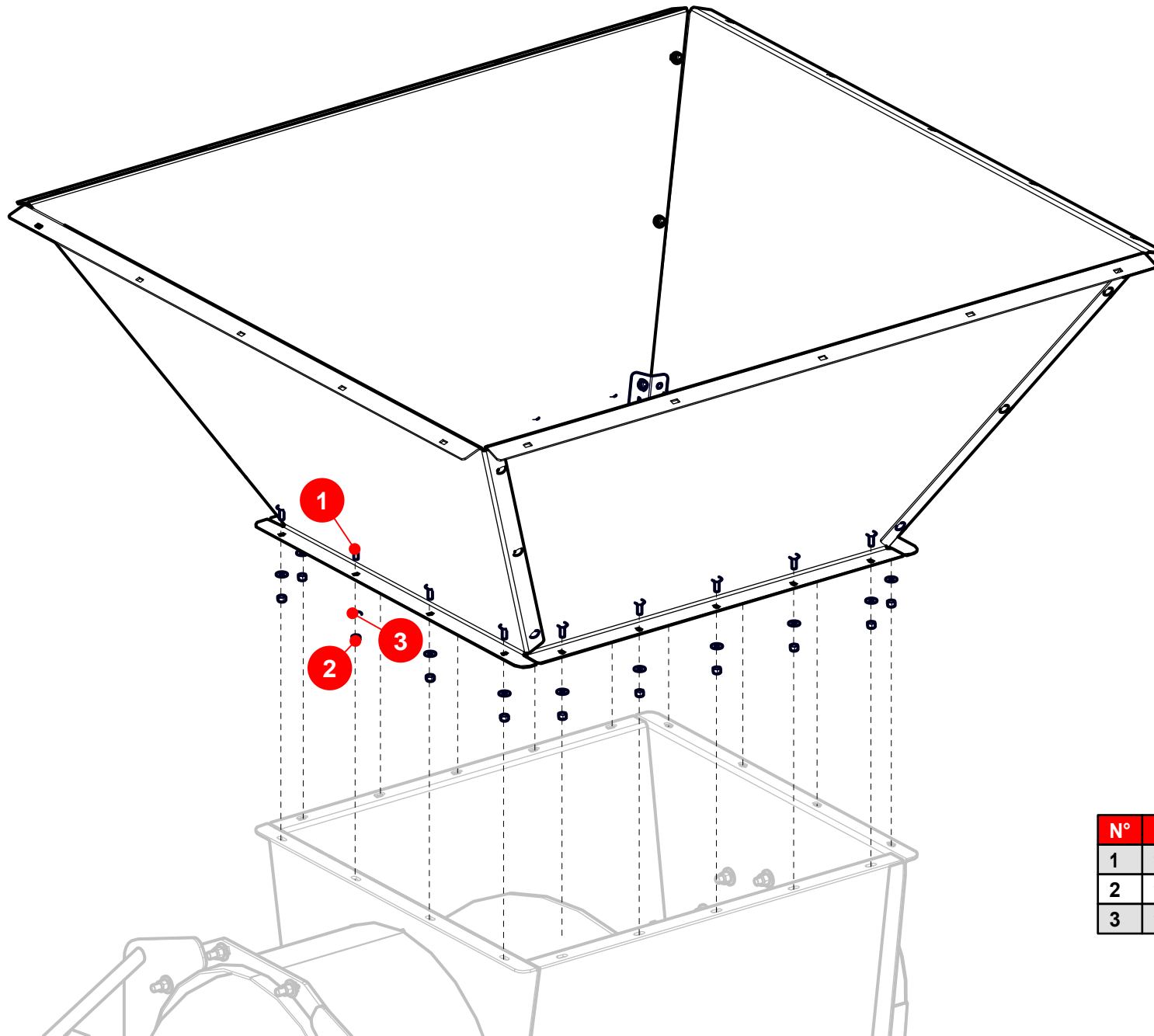

SIDE PANEL'S ASSEMBLY



HOPPER BASE ASSEMBLY



N°	PART	DESCRIPTION	QTY
1	98.190.079022	- Round head square neck	18
2	98.304.151079	- Lock Nut W 5/16"	18
3	98.309.101079	- Flat Washer 5/16"	18

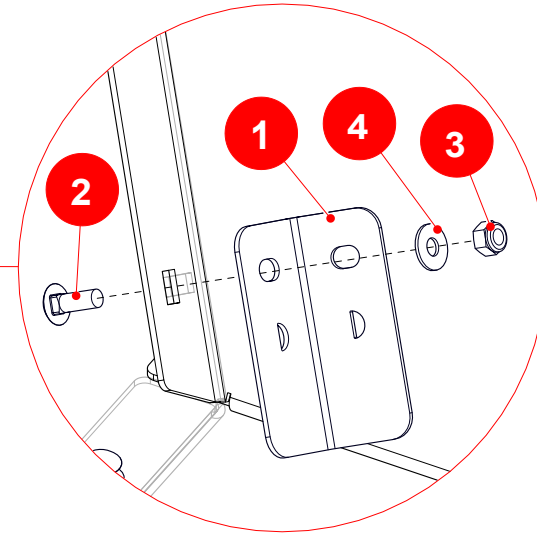
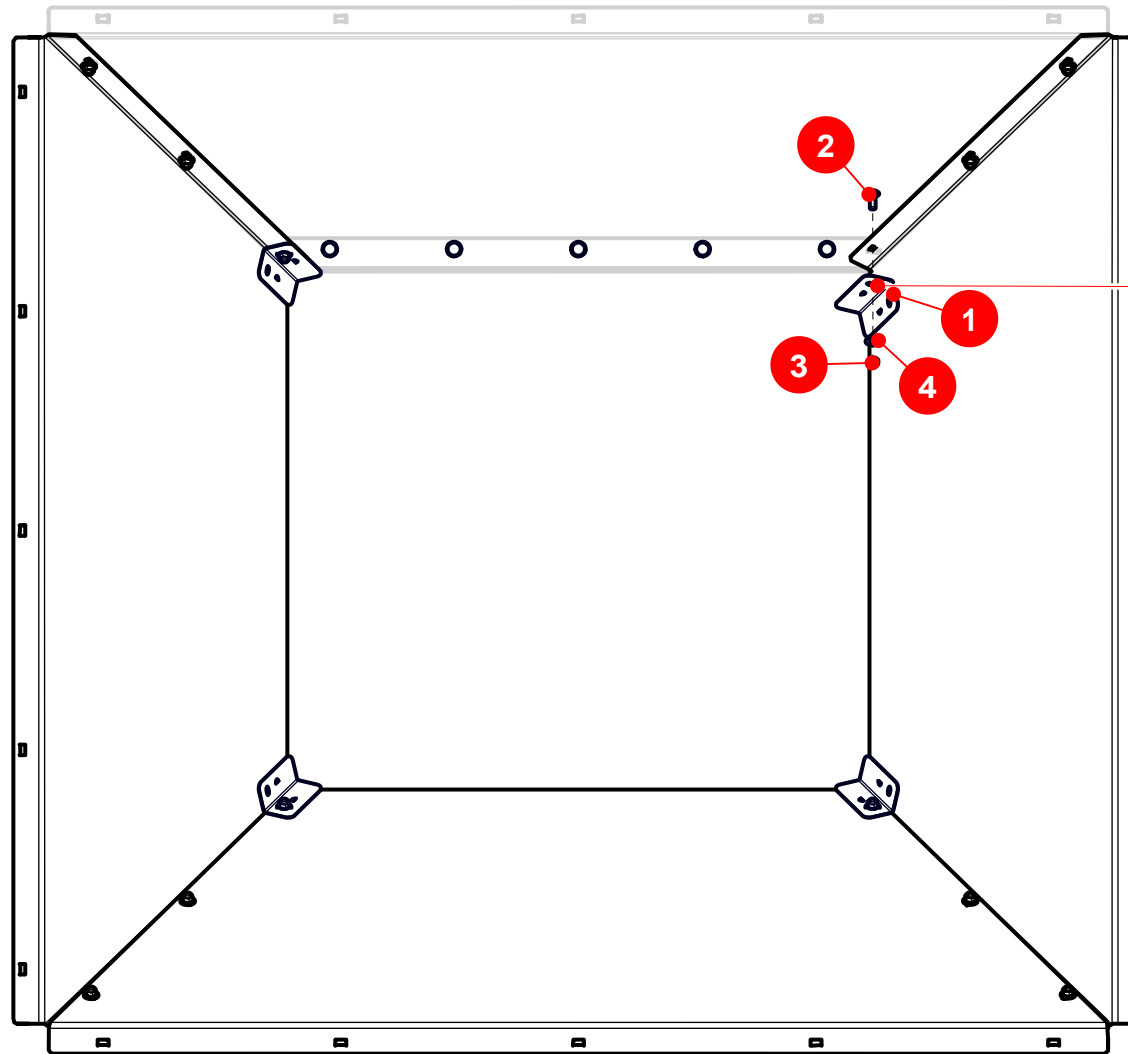

N°	PART	DESCRIPTION	QTY
1	29.42.34435	- - Cap	4
2	98.190.079022	- Round head square neck	4
3	98.304.151079	- Lock Nut W 5/16"	4
4	98.309.101079	- Flat Washer 5/16"	4

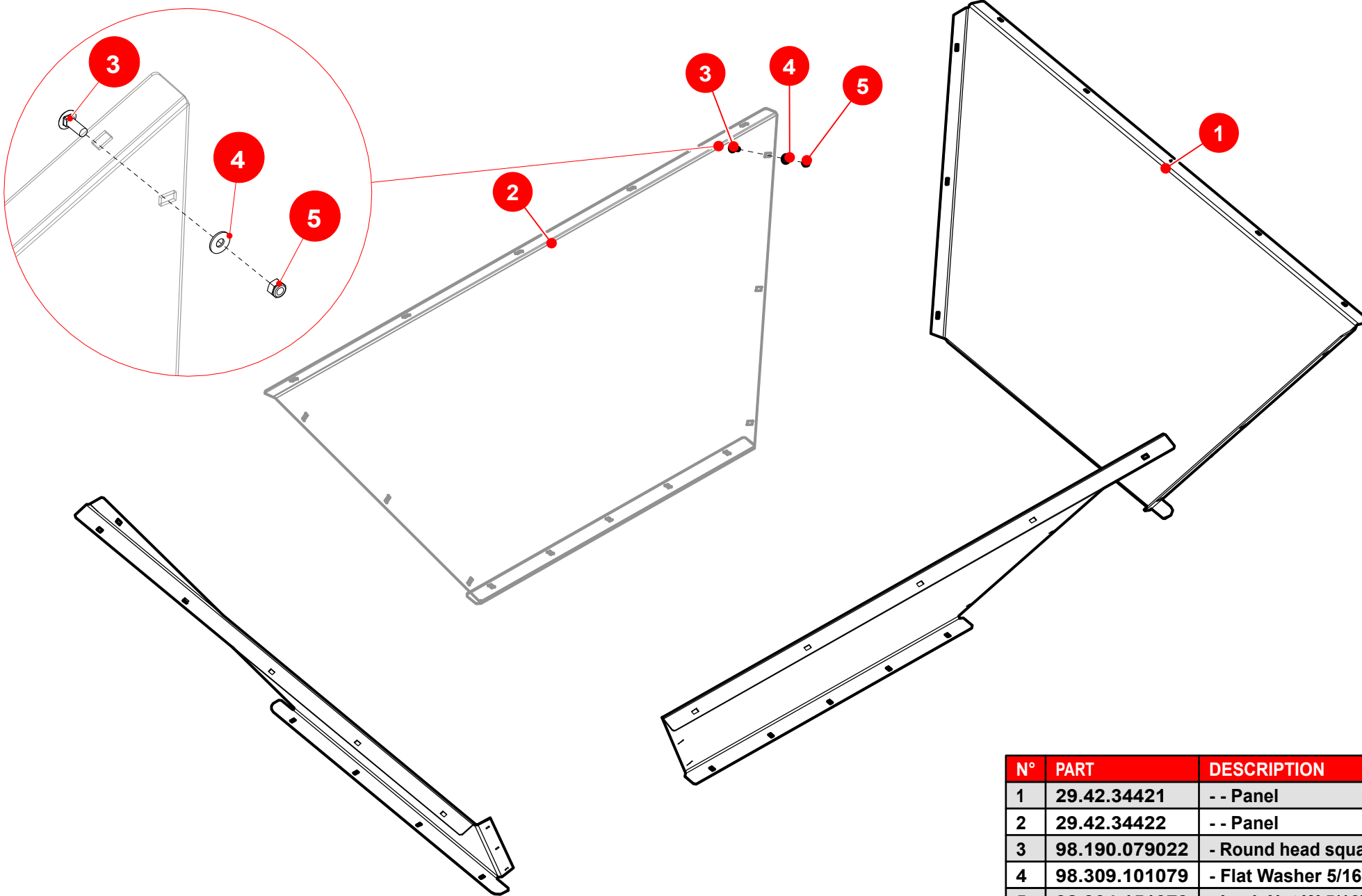

N°	PART	DESCRIPTION	QTY
1	29.42.34421	- - Panel	2
2	29.42.34422	- - Panel	2
3	98.190.079022	- Round head square neck	8
4	98.309.101079	- Flat Washer 5/16"	8
5	98.304.151079	- Lock Nut W 5/16"	8

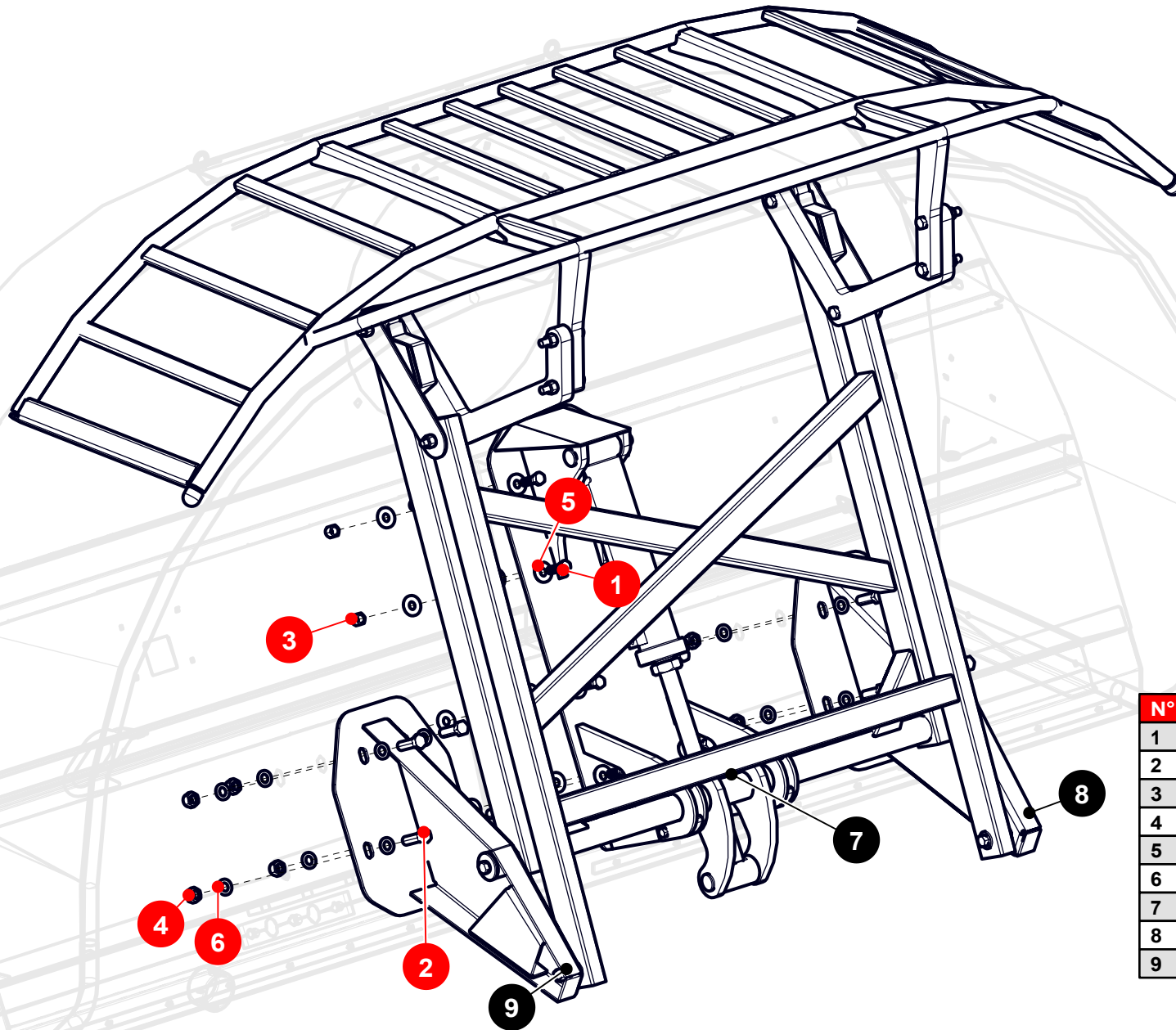

PARALLELOGRAM - CRADLE ASSEMBLY



HYDRAULIC CYLINDER ASSEMBLY



N°	PART	DESCRIPTION	QTY
1	98.002.158051	- Hex. Head Screw 5/8" X 2"	8
2	98.002.190063	- Hex. Head Screw 3/4" X 2 1/2"	8
3	98.304.110158	- Lock Nut W 5/8" X11	8
4	98.304.151190	- Lock Nut W 3/4" x 10h"	8
5	98.309.100158	- Flat Washer 5/8"	16
6	98.311.100190	- Chamfered Chamfered	16
7	29.39.34575	- Support Assembly	1
8	29.39.34590	- Support Assembly	1
9	29.39.34595	- Support Assembly	1

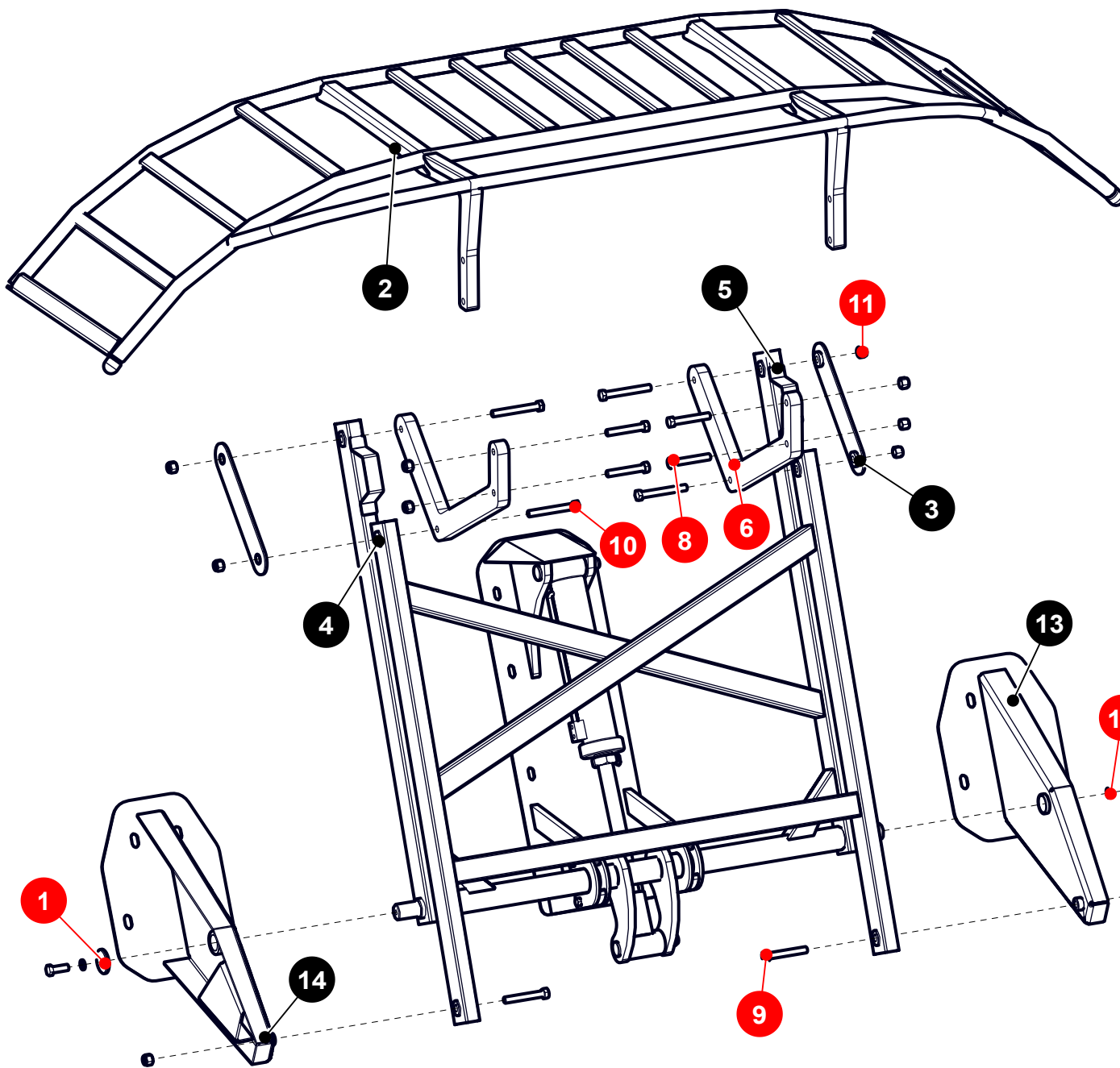

N°	PART	DESCRIPTION	QTY
1	25.43.21348	- - Washer	2
2	29.39.33540	- - Cradle	1
3	29.39.34510	- Support Assembly	2
4	29.39.34555	- - Arm Assembly	1
5	29.39.34585	- - Arm Assembly	1
6	29.42.34531	- Right Support	2
7	98.002.158044	- Hex. Head Screw 5/8" X 1 3/4"	2
8	98.002.158102	- Hex. Head Screw	4
9	98.002.158114	- Hex. Head Screw	2
10	98.002.158127	- Hex. Head Screw 5/8" X 5"	4
11	98.304.110158	- Lock Nut W 5/8" X11	10
12	98.310.101158	- Grower Washer 5/8"	2
13	29.39.34590	- Support Assembly	1
14	29.39.34595	- Support Assembly	1

N°	PART	DESCRIPTION	QTY
1	29.39.34575	- Support Assembly	1
2	29.39.34579	-- Cylinder end	1
3	29.39.34580	-- Hydraulic Cylinder Rod Clevis	1
4	29.39.34585	-- Arm Assembly	1
5	29.42.34588	- Fastening	4
6	29.43.34587	-- Lock Pin	2
7	98.002.127063	- Hex. Head Screw	4
8	98.300.300381	- Lock Nut CONTRATUERCA 1 1/2" NF	1
9	98.304.151127	- Lock Nut G5 1/2" RW	4
10	98.309.101127	- Flat Washer Ø 1/2"	4
11	98.334.050060	-- Split pin PASADOR DEALETA Ø 5 X 60 mm	2
12	98.378.034576	-- Hydraulic Cylinder	1

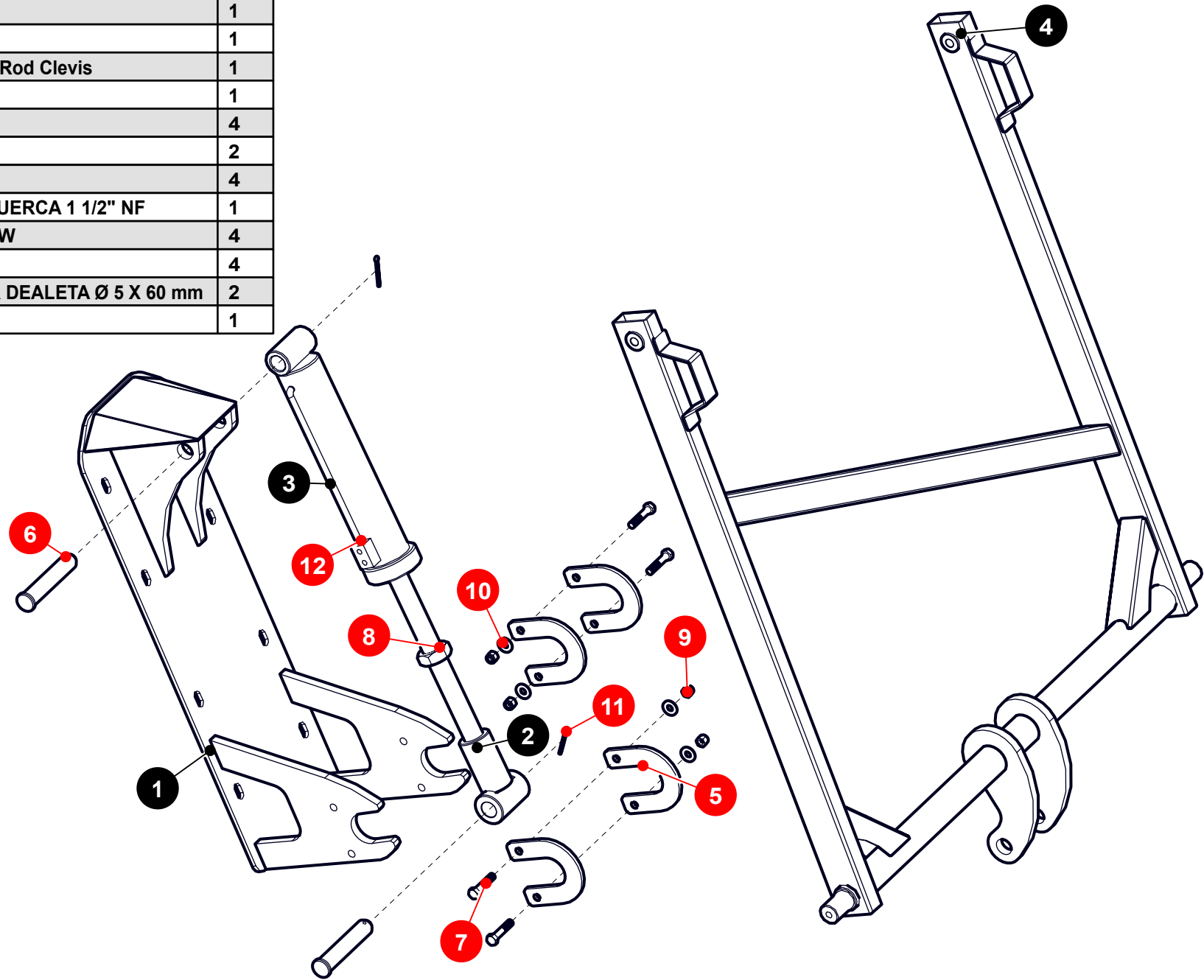

29.29.34941 - 3 SPOOL

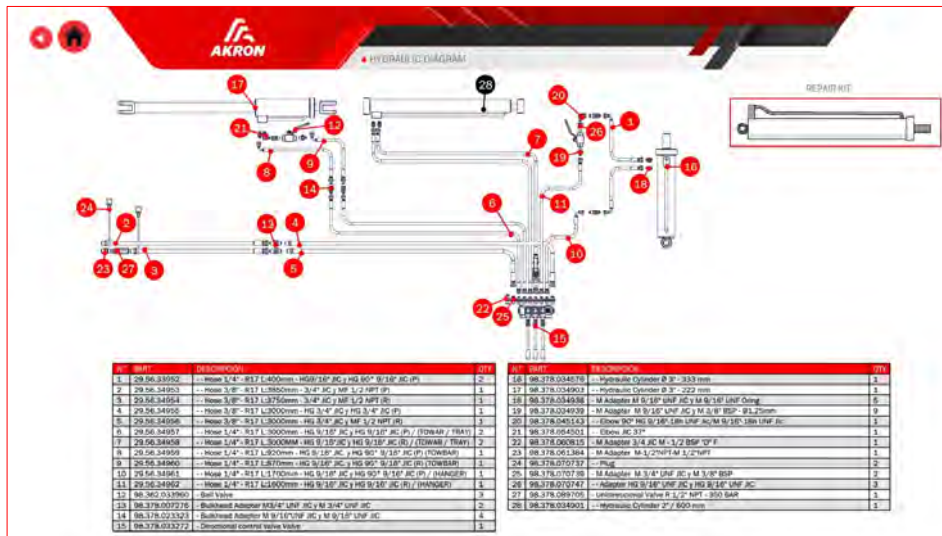

29.29.34940 - 2 SPOOL

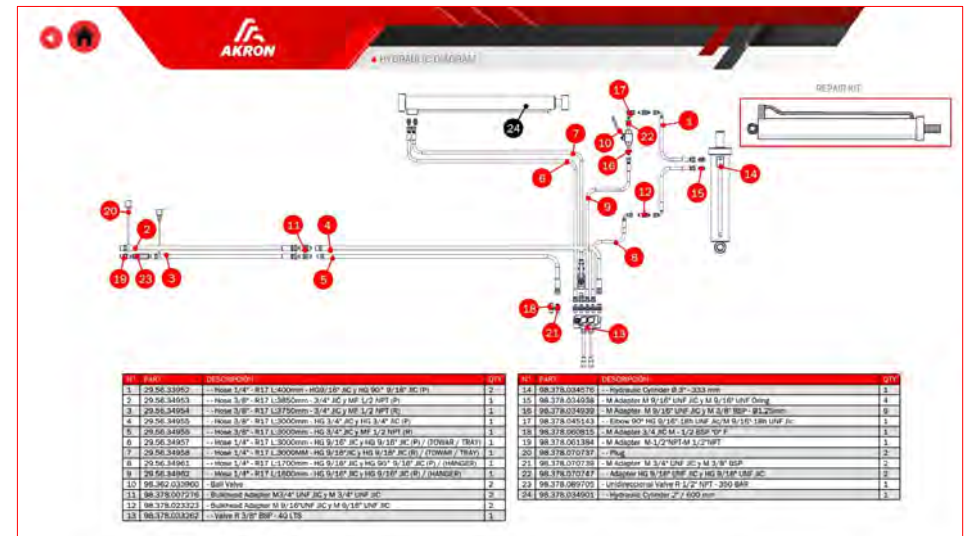

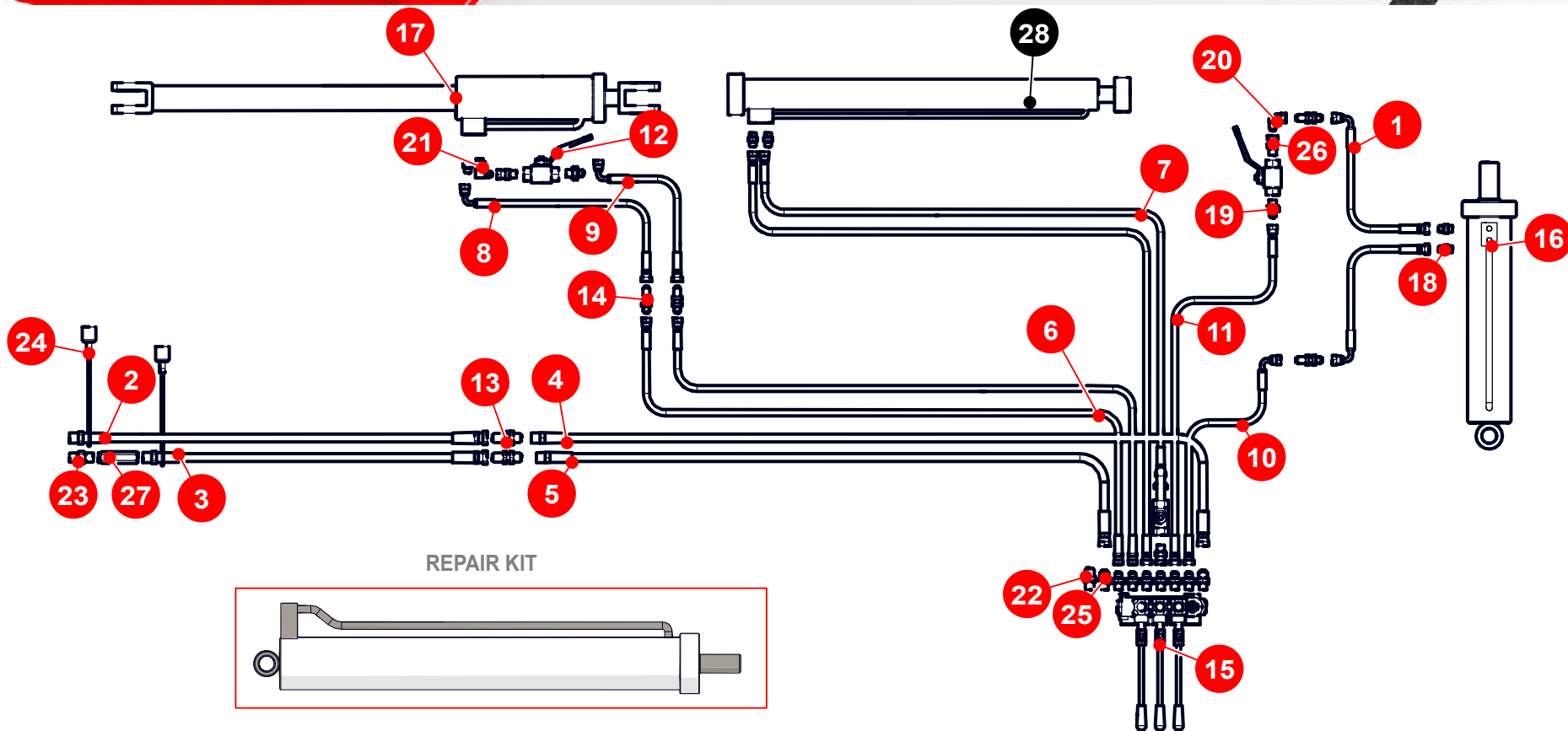

REPAIR KIT

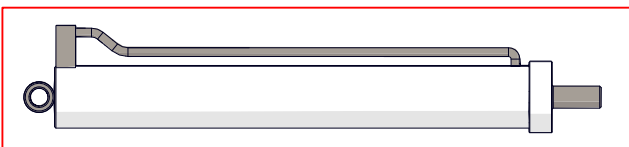

N°	PART	DESCRIPCIÓN	QTY
1	29.56.33952	-- Hose 1/4" - R17 L:400mm - HG9/16" JIC y HG 90° 9/16" JIC (P)	2
2	29.56.34953	-- Hose 3/8" - R17 L:3850mm - 3/4" JIC y MF 1/2 NPT (P)	1
3	29.56.34954	-- Hose 3/8" - R17 L:3750mm - 3/4" JIC y MF 1/2 NPT (R)	1
4	29.56.34955	-- Hose 3/8" - R17 L:3000mm - HG 3/4" JIC y HG 3/4" JIC (P)	1
5	29.56.34956	-- Hose 3/8" - R17 L:3000mm - HG 3/4" JIC y MF 1/2 NPT (R)	1
6	29.56.34957	-- Hose 1/4" - R17 L:3000mm - HG 9/16" JIC y HG 9/16" JIC (P) / (TOWAR / TRAY)	2
7	29.56.34958	-- Hose 1/4" - R17 L:3000MM - HG 9/16" JIC y HG 9/16" JIC (R) / (TOWAR / TRAY)	2
8	29.56.34959	-- Hose 1/4" - R17 L:920mm - HG 9/16" JIC. y HG 90° 9/16" JIC (P) (TOWBAR)	1
9	29.56.34960	-- Hose 1/4" - R17 L:870mm - HG 9/16" JIC. y HG 90° 9/16" JIC (R) (TOWBAR)	1
10	29.56.34961	-- Hose 1/4" - R17 L:1700mm - HG 9/16" JIC y HG 90° 9/16" JIC (P) / (HANGER)	1
11	29.56.34962	-- Hose 1/4" - R17 L:1600mm - HG 9/16" JIC y HG 9/16" JIC (R) / (HANGER)	1
12	98.362.033960	- Ball Valve	3
13	98.378.007276	- Bulkhead Adapter M3/4" UNF JIC y M 3/4" UNF JIC	2
14	98.378.023323	- Bulkhead Adapter M 9/16" UNF JIC y M 9/16" UNF JIC	4
15	98.378.033272	- Directional control valve Valve	1

N°	PART	DESCRIPCIÓN	QTY
16	98.378.034576	-- Hydraulic Cylinder Ø 3" - 333 mm	1
17	98.378.034903	-- Hydraulic Cylinder Ø 3" - 222 mm	1
18	98.378.034938	- M Adapter M 9/16" UNF JIC y M 9/16" UNF Oring	5
19	98.378.034939	- M Adapter M 9/16" UNF JIC y M 3/8" BSP - Ø1.25mm	9
20	98.378.045143	-- Elbow 90° HG 9/16"-18h UNF Jic/M 9/16"-18h UNF Jic	1
21	98.378.054501	-- Elbow JIC 37°	1
22	98.378.060815	- M Adapter 3/4 JIC M - 1/2 BSP "O" F	1
23	98.378.061384	- M Adapter M-1/2"NPT-M 1/2"NPT	1
24	98.378.070737	-- Plug	2
25	98.378.070739	- M Adapter M 3/4" UNF JIC y M 3/8" BSP	2
26	98.378.070747	-- Adapter HG 9/16" UNF JIC y HG 9/16" UNF JIC	3
27	98.378.089705	- Unidireccional Valve R 1/2" NPT - 350 BAR	1
28	98.378.034901	-- Hydraulic Cylinder 2" / 600 mm	1

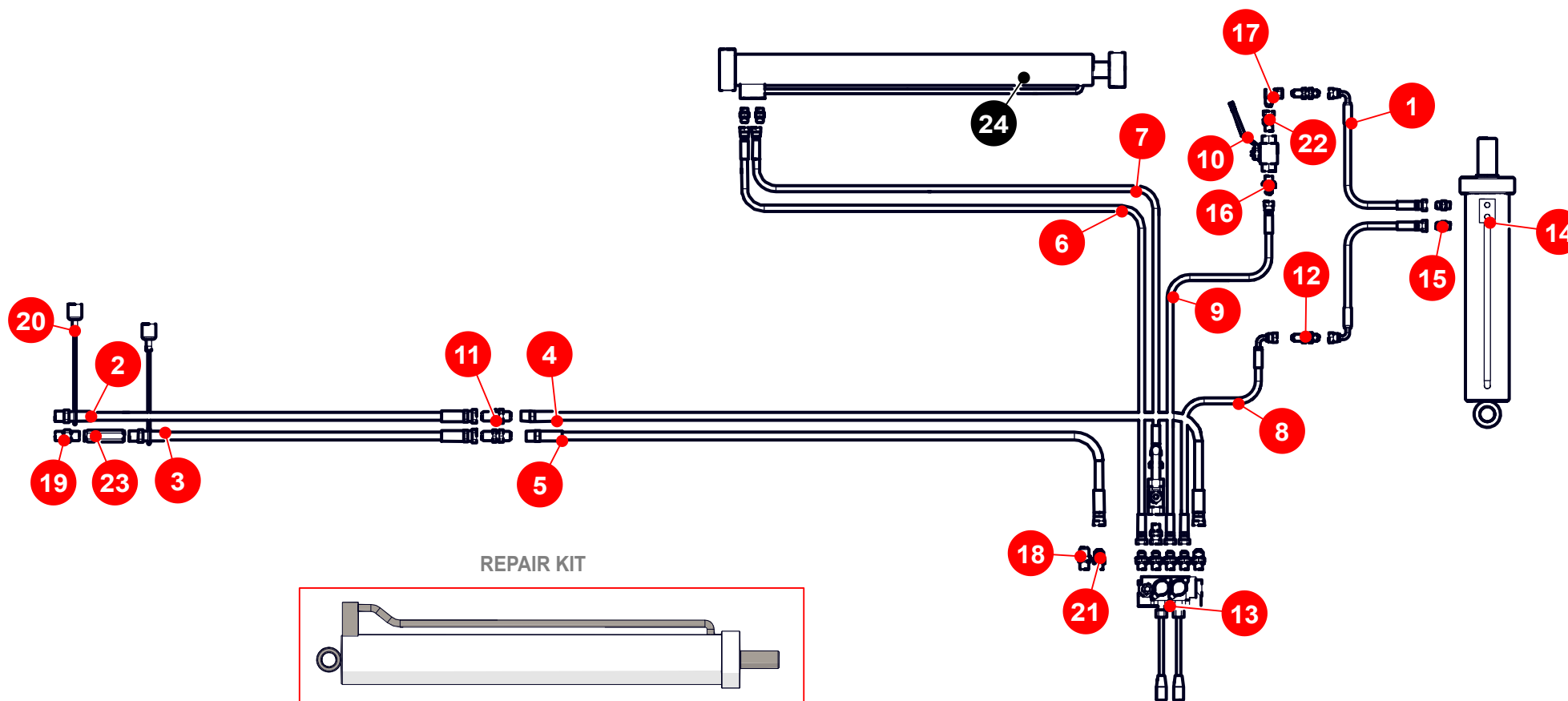

N°	PART	DESCRIPCIÓN	QTY
1	29.56.33952	-- Hose 1/4" - R17 L:400mm - HG9/16" JIC y HG 90° 9/16" JIC (P)	2
2	29.56.34953	-- Hose 3/8" - R17 L:3850mm - 3/4" JIC y MF 1/2 NPT (P)	1
3	29.56.34954	-- Hose 3/8" - R17 L:3750mm - 3/4" JIC y MF 1/2 NPT (R)	1
4	29.56.34955	-- Hose 3/8" - R17 L:3000mm - HG 3/4" JIC y HG 3/4" JIC (P)	1
5	29.56.34956	-- Hose 3/8" - R17 L:3000mm - HG 3/4" JIC y MF 1/2 NPT (R)	1
6	29.56.34957	-- Hose 1/4" - R17 L:3000mm - HG 9/16" JIC y HG 9/16" JIC (P) / (TOWAR / TRAY)	1
7	29.56.34958	-- Hose 1/4" - R17 L:3000MM - HG 9/16"JIC y HG 9/16" JIC (R) / (TOWAR / TRAY)	1
8	29.56.34961	-- Hose 1/4" - R17 L:1700mm - HG 9/16" JIC y HG 90° 9/16" JIC (P) / (HANGER)	1
9	29.56.34962	-- Hose 1/4" - R17 L:1600mm - HG 9/16" JIC y HG 9/16" JIC (R) / (HANGER)	1
10	98.362.033960	- Ball Valve	2
11	98.378.007276	- Bulkhead Adapter M3/4" UNF JIC y M 3/4" UNF JIC	2
12	98.378.023323	- Bulkhead Adapter M 9/16"UNF JIC y M 9/16" UNF JIC	2
13	98.378.033262	-- Valve R 3/8" BSP - 40 LTS	1

N°	PART	DESCRIPCIÓN	QTY
14	98.378.034576	-- Hydraulic Cylinder Ø 3" - 333 mm	1
15	98.378.034938	- M Adapter M 9/16" UNF JIC y M 9/16" UNF Oring	4
16	98.378.034939	- M Adapter M 9/16" UNF JIC y M 3/8" BSP - Ø1.25mm	6
17	98.378.045143	-- Elbow 90° HG 9/16"-18h UNF Jic/M 9/16"-18h UNF Jic	1
18	98.378.060815	- M Adapter 3/4 JIC M - 1/2 BSP "O" F	1
19	98.378.061384	- M Adapter M-1/2"NPT-M 1/2"NPT	1
20	98.378.070737	-- Plug	2
21	98.378.070739	- M Adapter M 3/4" UNF JIC y M 3/8" BSP	2
22	98.378.070747	-- Adapter HG 9/16" UNF JIC y HG 9/16" UNF JIC	2
23	98.378.089705	- Unidireccional Valve R 1/2" NPT - 350 BAR	1
24	98.378.034901	-- Hydraulic Cylinder 2" / 600 mm	1

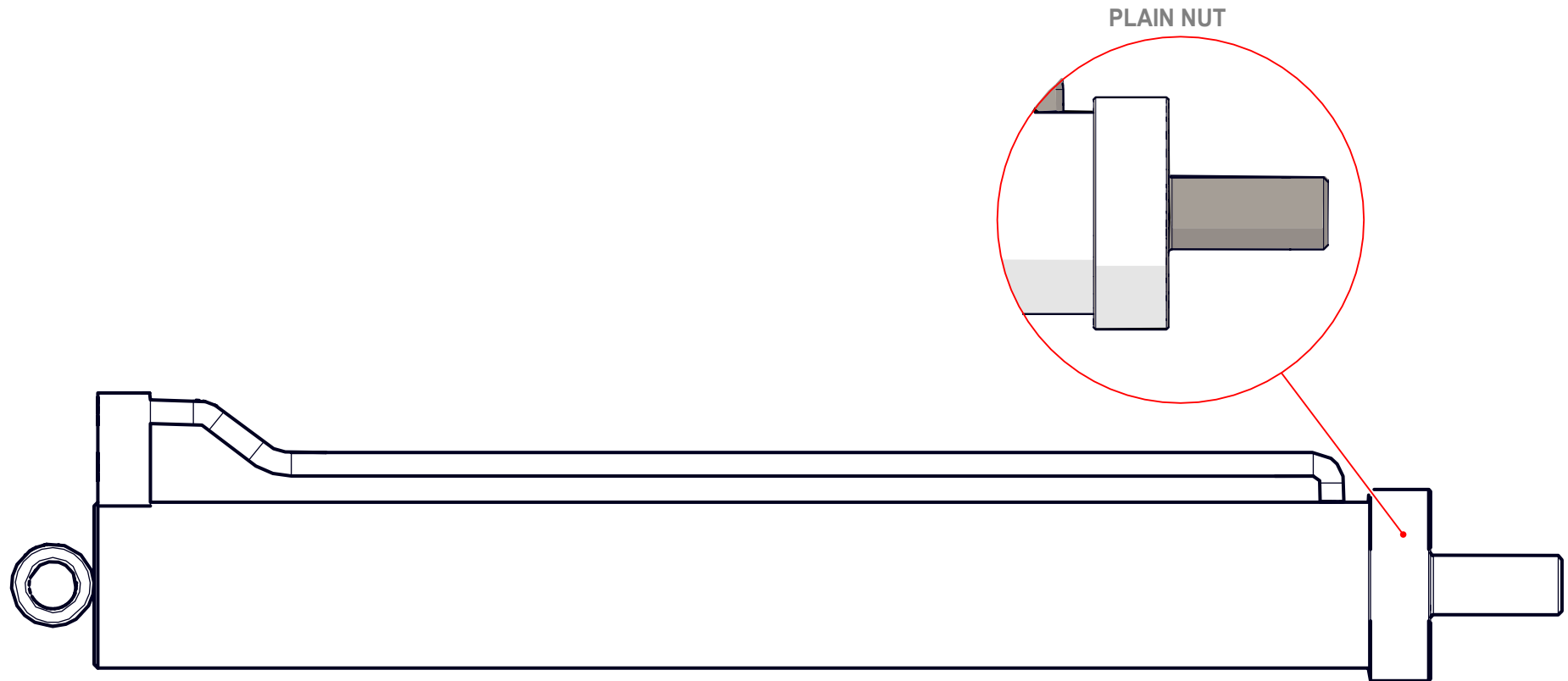

DALAGI		
AKRON	PART	DESCRIPTION
98.378.034576	98.378.200508	Hydraulic Cylinder Repair Kit Ø2"
98.378.034901	98.378.200762	Hydraulic Cylinder Repair Kit Ø3"



MORO		
AKRON	PART	DESCRIPTION
98.378.034576	98.378.100508	Hydraulic Cylinder Repair Kit Ø2"
98.378.034901	98.378.100762	Hydraulic Cylinder Repair Kit Ø3"

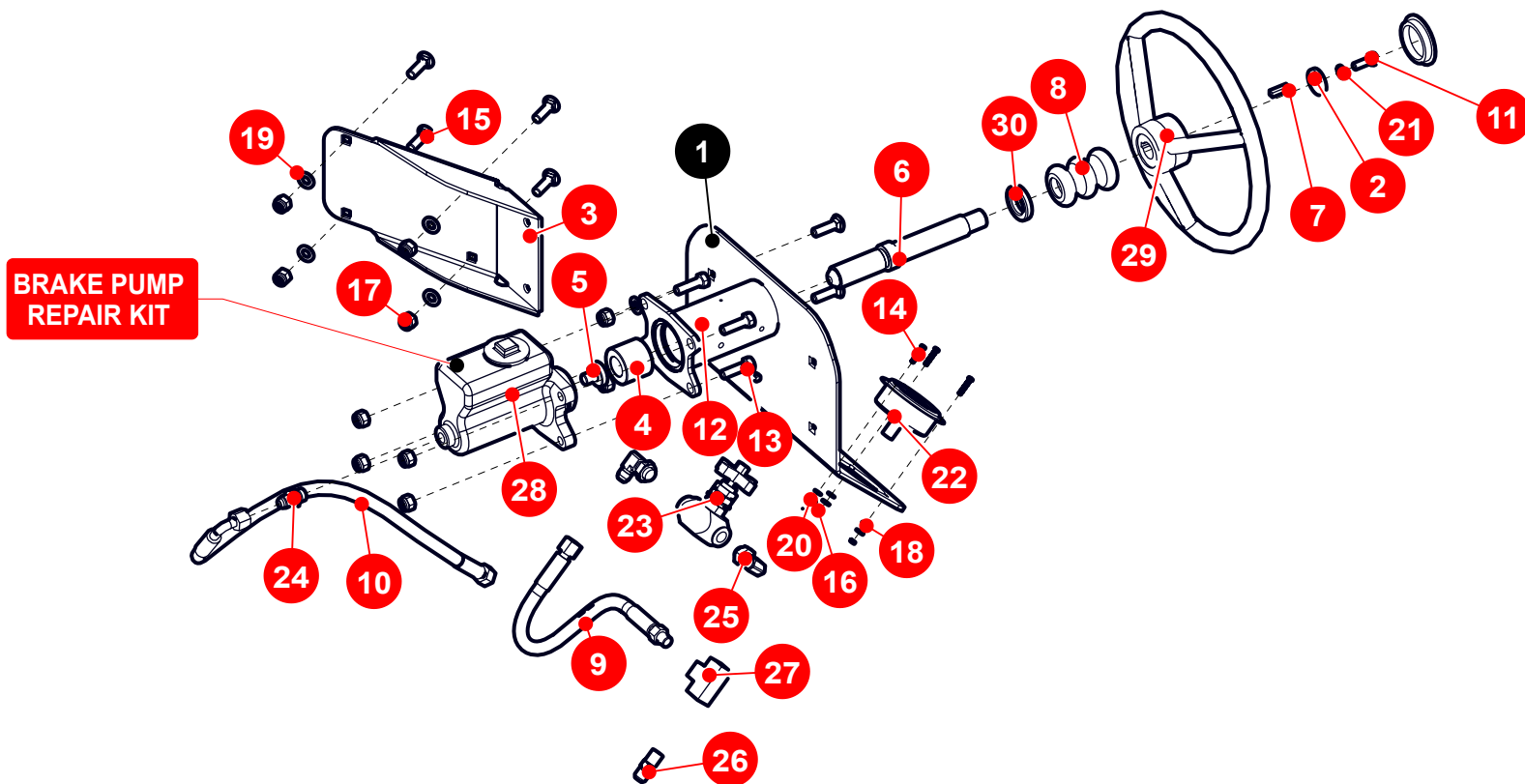

N°	PART	DESCRIPTION	QTY
1	29.39.35839	-- Brake system	1
2	29.42.27807	-- Cap	1
3	29.42.35837	-- Support	1
4	29.43.27804	-- Nut	1
5	29.43.27806	-- Supplement	1
6	29.43.27808	-- Shaft	1
7	29.43.27810	-- Cotter pin	1
8	29.46.27820	-- Strap	1
9	29.56.27816	-- Hose MF 1/4" NPT X HG 9/16"x18h JIC 37°	1
10	29.56.35814	-- Hose HG 90° 9/16" JIC X JIC 37° 9/16" x 18h	1
11	98.002.079022	- Hex. Head Screw 5/16" X 7/8"	1
12	98.002.095032	- Hex. Head Screw Ø3/8" X 1 1/4" G5	4
13	98.061.063022	-- Stud	1
14	98.173.039019	- Button Head	3
15	98.190.095032	- Round head square neck	6
16	98.301.150039	- Hex Nut TUERCA EXAG.G5 5/32" RW	3

N°	PART	DESCRIPTION	QTY
17	98.304.151095	- Lock Nut RW 3/8"	10
18	98.309.100039	- Flat Washer 5/32"	3
19	98.309.100095	- Flat Washer 3/8"	6
20	98.310.100039	- Grower Grower	3
21	98.310.100079	- Grower Washer 5/16"	1
22	98.378.027811	-- Hydraulic Cylinder	1
23	98.378.027815	- Directional control valve Valve VALVULA DE AGUJA NACIONAL	1
24	98.378.035135	- Hydraulic Cylinder ADAPTADOR ASIENTO MACHO JIC 37° x Asiento O'Ring plano	1
25	98.378.054501	-- Hydraulic Cylinder	2
26	98.378.060135	- M Adapter ADAPTADOR MACHO/MACHO 1/4" NPT X 9/16 Jic	1
27	98.378.071985	-- Hydraulic Cylinder	1
28	98.395.027808	-- Brake Pump	1
29	98.408.027809	-- Handwheel	1
30	98.610.171794	- SAV	1

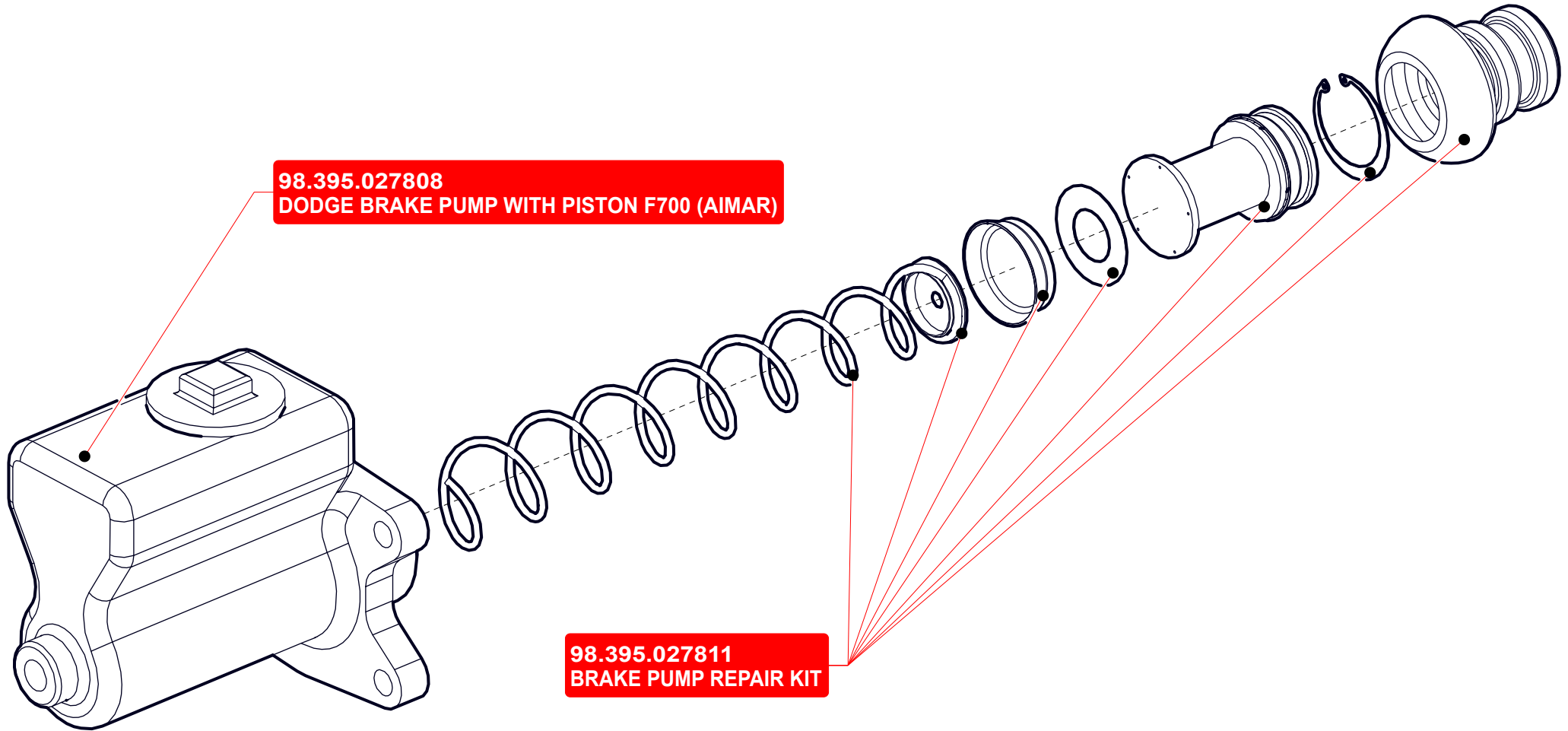

98.395.027808
DODGE BRAKE PUMP WITH PISTON F700 (AIMAR)

98.395.027811
BRAKE PUMP REPAIR KIT

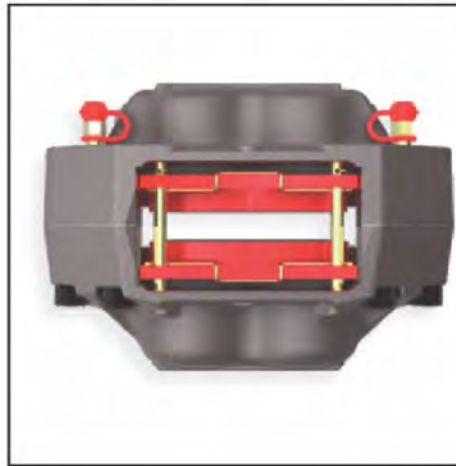

- 1 - DUSTA SHIELD
- 2 - PISTON SEAL
- 3 - BRAKE PAD
- 4 - BRAKE PISTON

05/98.395.022305 AIMAR UNIVERSAL CALIPERREPAIR KIT

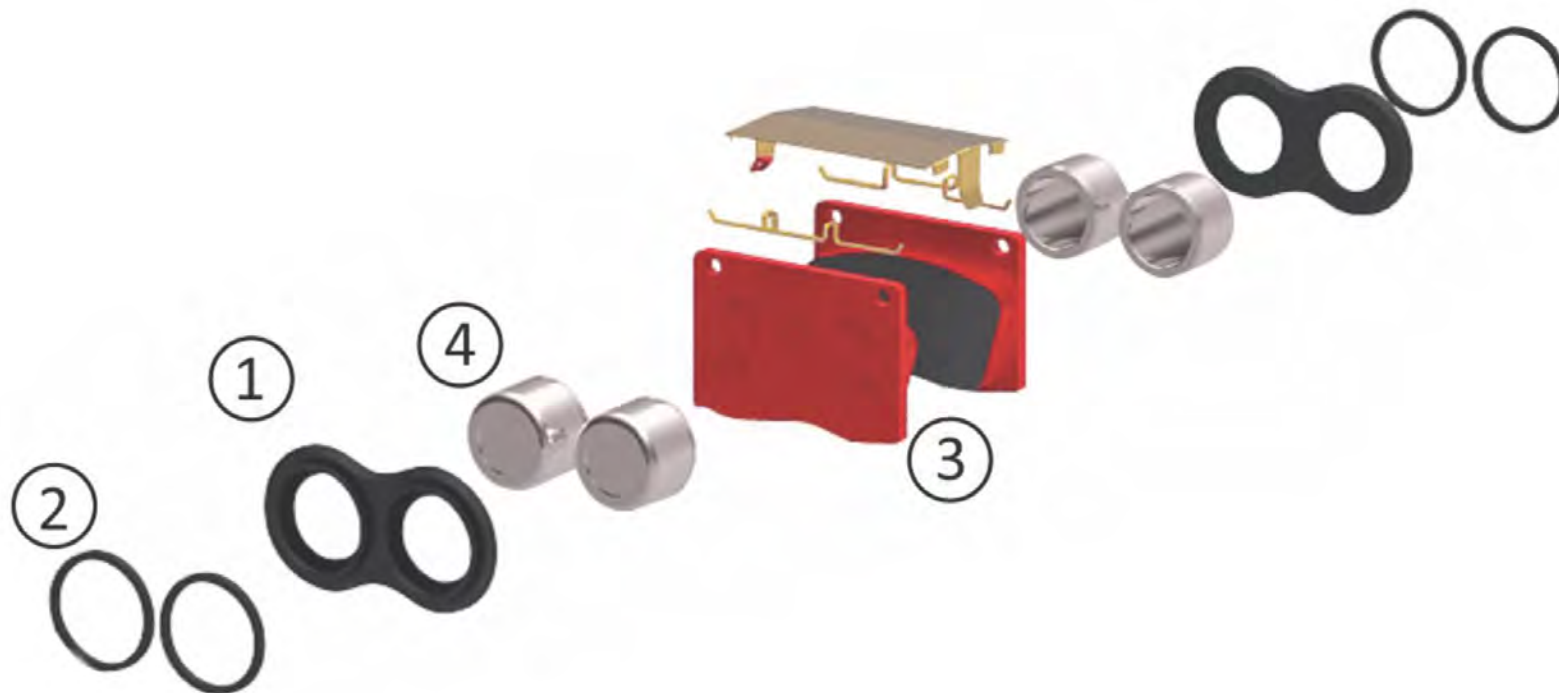

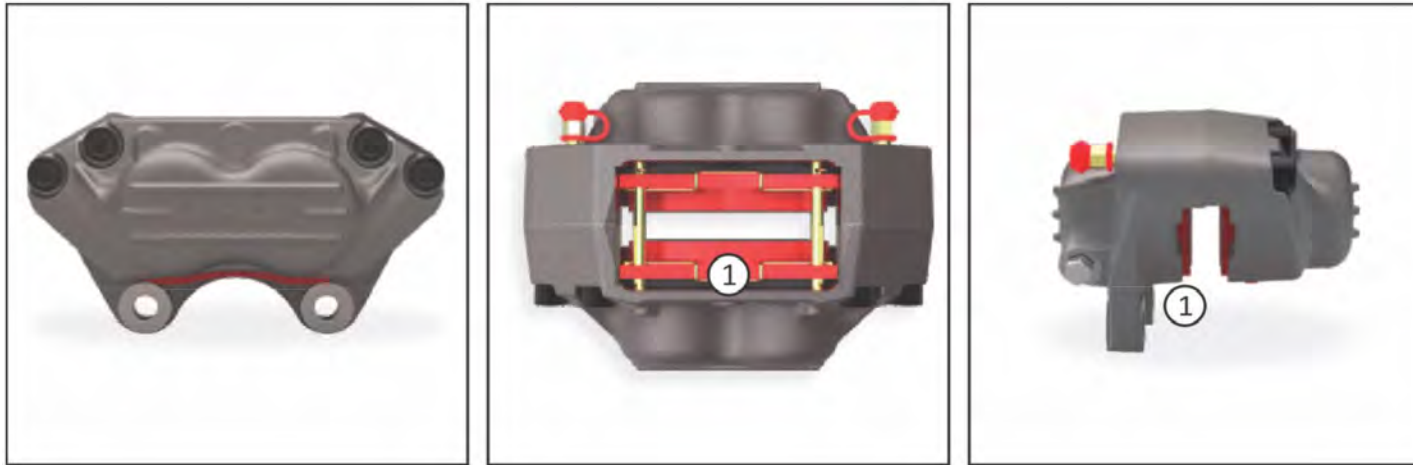

1 - BRAKE PAD

05/98.395.022315 AIMAR BRAKE PAD SET



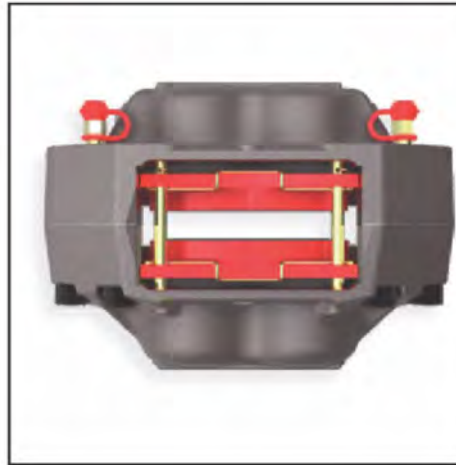

05/98.395.022312 AIMAR RUBBER SEALS SET



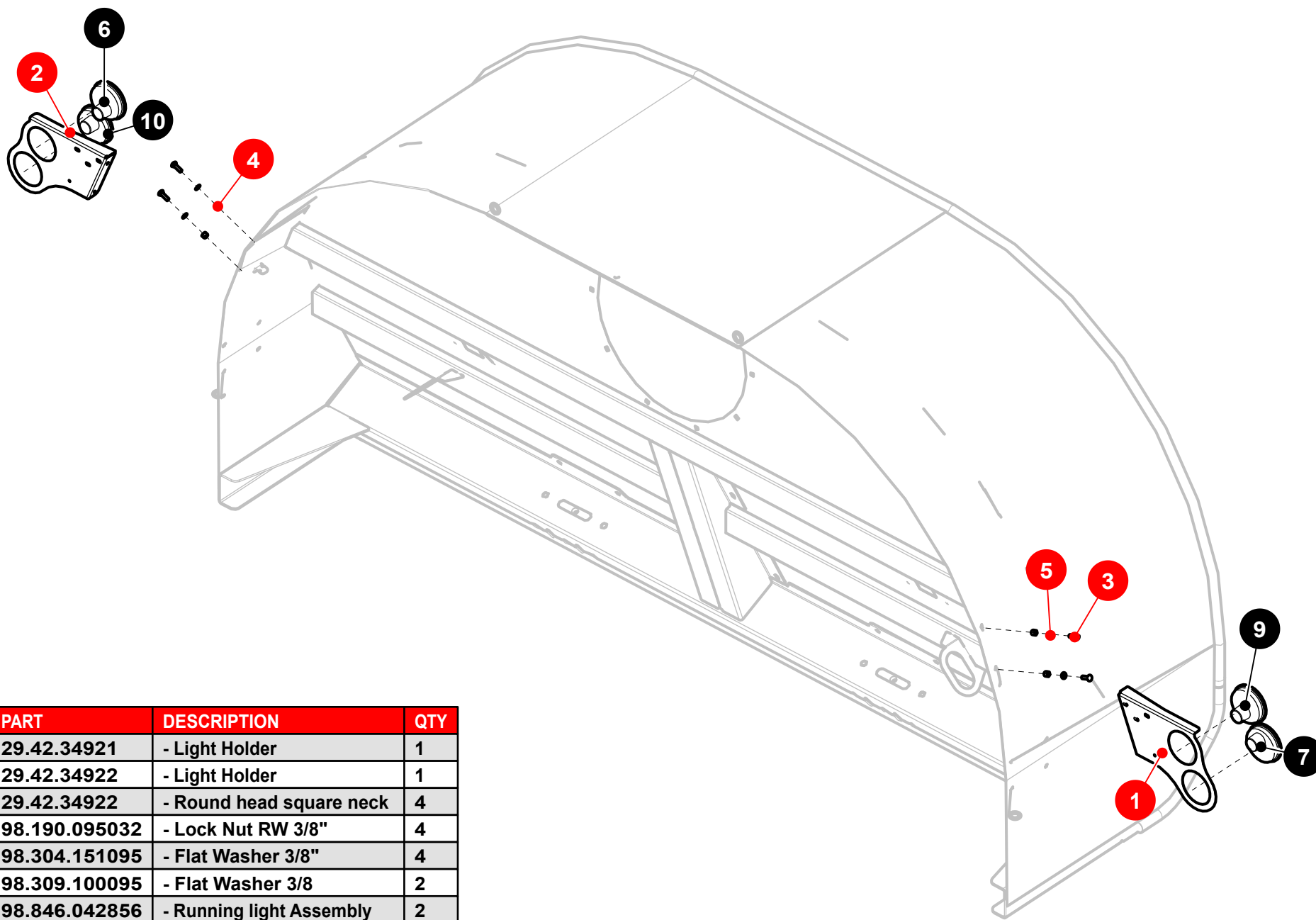

N°	PART	DESCRIPTION	QTY
1	29.42.34921	- Light Holder	1
2	29.42.34922	- Light Holder	1
3	29.42.34922	- Round head square neck	4
4	98.190.095032	- Lock Nut RW 3/8"	4
5	98.304.151095	- Flat Washer 3/8"	4
6	98.309.100095	- Flat Washer 3/8"	2
7	98.846.042856	- Running light Assembly	2



7-Pin male plug, SAE J650.

2-Pin SS male connector.
Put the plug cap.

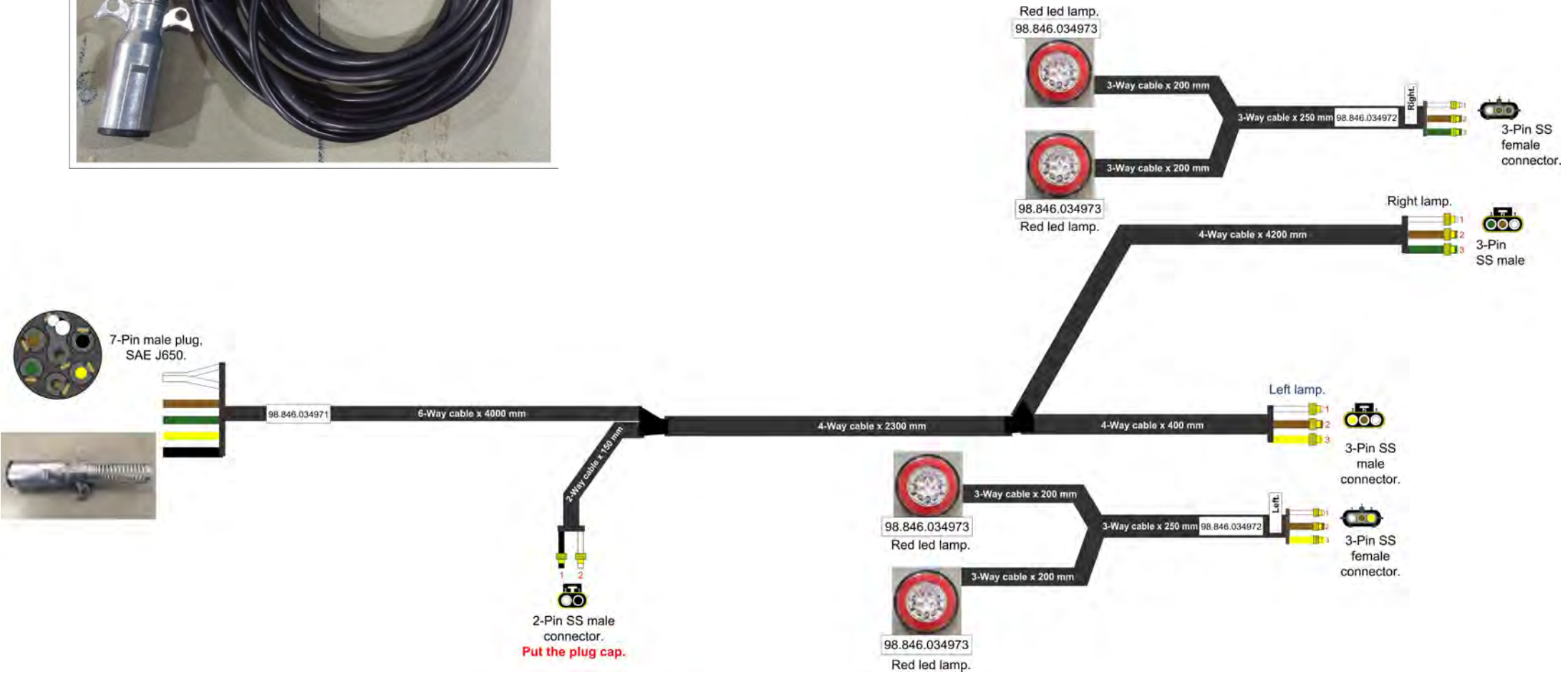

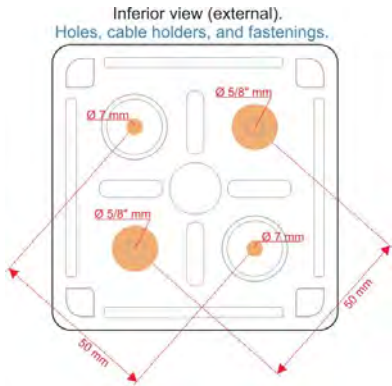
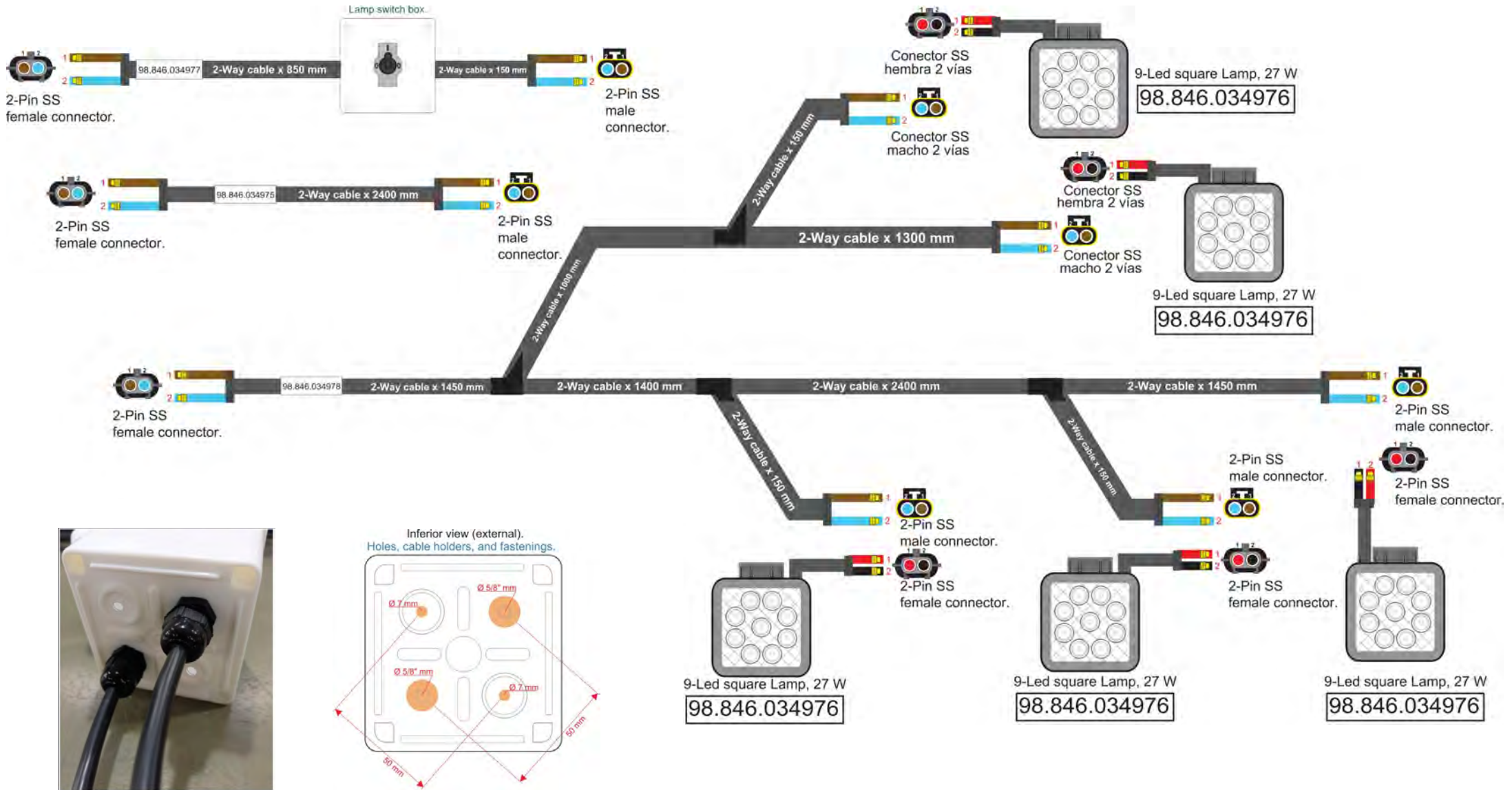

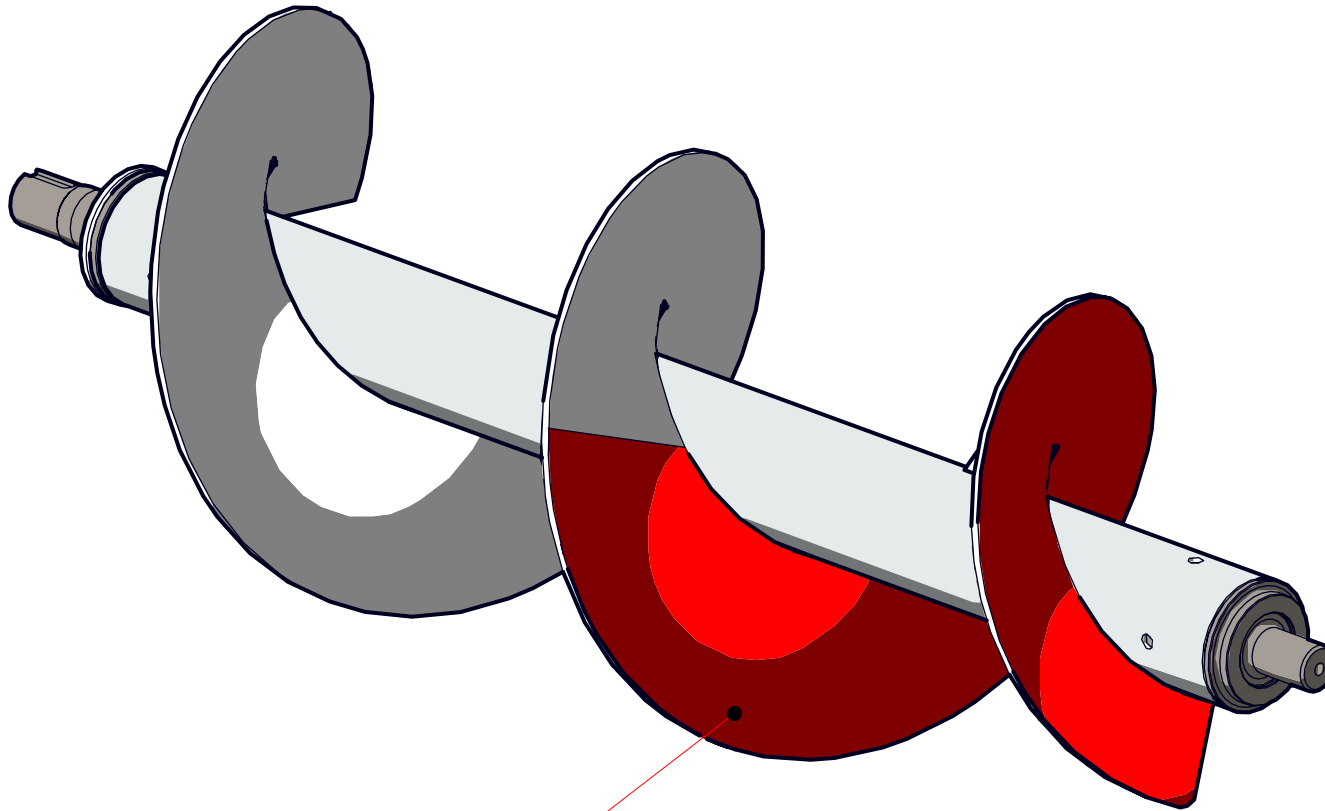

ONE BIT OF THE AUGER IS FULLY CASE-HARDENED.
MINIMUM HARDENED LAYER DEPTH: 1.5 mm