

AKRON



User's Manual

OPERATION, MAINTENANCE AND SPARE PARTS

GRAIN EXTRACTOR

EXG 300

User's Manual

Operation, Maintenance
and Spare Parts

Code: 187000

Edition: June 2010

Review: 2010/004_1

Due to the continuing improvements in the design and manufacture of **AKRON®** products, **MICRÓN FRESAR S.R.L.** reserves the right to modify components and/or specifications without prior notice.

1. INTRODUCTION

The present user's manual describes the functions and components of the **AKRON®** grain extractor model **EXG 300**. It gives detailed safety instructions and provides recommendations for its operation, also offering a general maintenance guide for the machine.

The information provided in this manual is fundamental for the efficient and safe operation of the machine. This documentation is included with the machine in order to guarantee its optimal operation. That is why this manual should be available at all times either together with the machine or at least within the operators' and supervisors' reach.

1-a. The Purpose of the Machine

The **EXG 300** grain bag unloader has been designed to safely unload grain and oilseeds that have been stored in chamber conditions in standard grain bags during the recommended period for each grain type, and store them in grain carts or tucks.

The simple concept of design of this machine requires very little maintenance and ensures a good operation under different conditions. However, it is important to highlight that this grain extractor is exclusively designed to work with grain bags, and that the warranty will be valid as long as the machine is used according to the instructions for use detailed in this manual.

Before operating, servicing or repairing this machine, the instructions given in the present manual and in any other documentation supplied by the manufacturer must be followed. Special attention must be paid to safety precautions and recommendations, and to compliance with the pertinent local Occupational Health & Safety laws in force.

Any arbitrary modification carried out on the machine or its components will release the manufacturer from any responsibility arising from damage or injury that may occur as a result of such modification.

2. GENERAL INDEX

1. Introduction	5
1-a The Purpose of the Machine	5
2. Index.	7
3. Safety	9
3-a Attitude Toward Safety	9
3-b "ATTENTION" Symbol and Signal Words	9
3-c Personal Protective Equipment	9
3-d Safety Warnings	9
3-e Risk Analysis	9
4. Receiving the Machine	13
4-a. Grain extractor identification	13
4-b. Contact Information	13
4-c. Operating Principle	14
5. Preparation and Setup	15
5.a Requerimientos de accionamiento	15
5.b Position changes	15
5.c Recommendations to Make Extraction Easier	17
5.d Previous Controls on the Machine	17
5.e Machine Layout	17
5.f Grain Bag Preparation	18
5.g Final Adjustments on the Machine	19
6. Set up for extraction	21
6.a. General Comments on the Storage in Grain bags	21
6-b Operation Start-up	22
6-c Operation Parameters	23
6-d Protection against Overloads	24
6-e Interruptions during Extraction	24
6-f Extraction at the End of the Bag	24
6-g Unwinding the Bag	25
7. Maintenance Program	27
7-a Maintenance Schedule	27
7-b. Maintenance after Receiving the Machine	27
7-c Desmantelamiento de piezas para su reparación	27
7-d Lubrication	28
7-e Prevention of Wear on Flexible Pipes	28
7-f Tire Change	28

8. Machine Transportation and Storage29
8-a Preparation of the Machine for Transportation29
8-b Transportation30
8-c Machine Storage31
8.d. Extractor Parking31
9. Specifications33
10. Product Dismantling and Disposal35
11. Guarantee Terms37
12. Alphabetical Index39
13. Spare Parts List41
13-a Information for Obtaining Spare Parts41
14.Parts subject to normal wear and tear69
15. User's Notes71

3. SAFETY

Even though the machine's operation is simple and safe, it is essential that all grain cart loading, unloading and transport operators and supervisors have an in-depth knowledge of the contents of this user's manual. In this way, situations of danger will be avoided for the operator, for third parties and for goods in the surrounding area.

There must be a written record of when the operators are trained in every detail of the machine's operation.

3-a. Attitude Toward Safety

Just as with the operation of any other machine, the most important factor for preventing accidents of any kind is the positive attitude of operators and supervisors toward safety. As well as following the manufacturer's recommendations, the habit must be developed of foreseeing and analyzing every possible contingency that could arise during the operation of the machine. Even though it is impossible to foresee all possible situations, this habit helps to prevent the majority of hazardous situations.

3-b. "ATTENTION" Symbol and Signal Words



Throughout the present manual, the "Attention" symbol is used to indicate risk situations for the operator, the machine, other equipment or other people.

This symbol will appear together with certain signal words depending on the relative seriousness of each risk situation.



DANGER: This identifies an imminent hazardous situation whose consequences may cause death or serious injuries if not avoided.





WARNING: This identifies a potential hazardous situation whose consequences may cause death or slight to moderate injuries if not avoided.



IMPORTANT: This describes a particular situation where the machine could be damaged or its normal operation could be affected.

3-c. Personal Protective Equipment

Micrón Fresar S. R. L. recommends the use of the following Personal Protective Equipment in order to avoid any possible injury:

Situation	Personal Protective Equipment		
			
Tractor driver	✓	✓	
Machine operator	✓	✓	✓

3-d. Safety Warnings

On different parts of the machine and on its accessories you will find decals with accident prevention symbols, which must be considered as part and extension of the instructions detailed in this manual. Special care must be taken to ensure these decals are present and legible during the entire working life of the machine.



















If for any reason any of these gets lost or becomes illegible through wear, it is important to substitute it immediately indicating its corresponding code. To ask for a replacement decal, please contact either the manufacturer using the information given in 4-b. "Contact information", or your local Technical Representative.

3-e. Risk Analysis

The risk situations that typically arise during the operation of this machine are detailed below. Recommendations are made that are of vital importance for the safety of the machine operators, of other workers nearby, and the machine itself.

The pictograms used are taken from IRAM standard 8075 "Tractors, agricultural and forestry and green space maintenance machinery - Safety signs and hazard pictograms - General principles and features". For more details, their location on the machine is shown in the following picture.

DECALS				
#	IMAGE	CODE	NAME	QTY
1		114138	<p><i>Risk situations:</i></p> <ul style="list-style-type: none"> • During machine transport <p><i>Particular recommendations:</i></p> <ul style="list-style-type: none"> • When transporting the grain cart, stay below the speed limit for safety reasons. 	1
2		114200	<p><i>Risk situations:</i></p> <ul style="list-style-type: none"> • During machine transport, During the discharge process <p><i>Particular recommendations:</i></p> <ul style="list-style-type: none"> • Do not climb or travel on the machine structure. 	1
3		114181	<p><i>Risk situations:</i></p> <ul style="list-style-type: none"> • During the discharge process <p><i>Particular recommendations:</i></p> <ul style="list-style-type: none"> • Keep a safe distance away from the machine. 	1
4		016135	<p><i>Risk situations:</i></p> <ul style="list-style-type: none"> • When operating the machine <p><i>Particular recommendations:</i></p> <ul style="list-style-type: none"> • Observe the warnings indicated in the pictogram in order to avoid accidents. 	1
5		114112	<p><i>Risk situations:</i></p> <ul style="list-style-type: none"> • When operating the machine or performing maintenance tasks <p><i>Particular recommendations:</i></p> <ul style="list-style-type: none"> • Carefully read the operator's manual so as to become acquainted with its features and operation. 	1
6		114122	<p><i>Risk situations:</i></p> <ul style="list-style-type: none"> • When performing maintenance tasks. <p><i>Particular recommendations:</i></p> <ul style="list-style-type: none"> • Stop the engine and remove the key before performing maintenance or preparation tasks. 	1
7		-	NOTICE	1
8		080112/110	Roll rotation direction in operation mode.	1
9		065822	Cardan coupling position	1
10		114186	Tying for transport	2
11		114152	<p><i>Risk situations:</i></p> <ul style="list-style-type: none"> • During the discharge process <p><i>Particular recommendations:</i></p> <ul style="list-style-type: none"> • Do not open or take away the safety protections while the motor is running. 	1
12		114178	<p><i>Risk situations:</i></p> <ul style="list-style-type: none"> • When handling the hydraulic circuit. <p><i>Particular recommendations:</i></p> <ul style="list-style-type: none"> • Check circuit for proper operation. • Check flexible pipes' condition. 	1
13		187139	<p><i>Risk situations:</i></p> <ul style="list-style-type: none"> • when handling the roll. <p><i>Particular recommendations:</i></p> <ul style="list-style-type: none"> • Avoid hand crushing when turning the roll into operating position. 	1
14		187140	<p><i>Risk situations:</i></p> <ul style="list-style-type: none"> • when handling the roll. <p><i>Particular recommendations:</i></p> <ul style="list-style-type: none"> • Avoid arm crushing while the roll is operating. 	1
15		187132	Switch valve.	1

#	IMAGE	CODE	NAME	QTY
16		114162	<i>Risk situations:</i> • During the discharge process. <i>Particular recommendations:</i> • Do not stand within reach of the auger or introduce your hand while the motor is running.	1
17		180108	Cutting blade.	1
18		182130	<i>Risk situations:</i> • Machine tune-up. <i>Particular recommendations:</i> • Caution during the operation process.	1
19		180100	• <i>Risk situations:</i> When transporting the machine. • <i>Particular recommendations:</i> Avoid contact with power lines, especially when the auger tube is unfolded.	1
20		135133	End of bag.	20
21		014128	Maximum 540 rpm.	1
22		114132	<i>Risk situations:</i> • When operating the machine or performing maintenance tasks. • During the process of grain discharge. <i>Particular recommendations:</i> • Never use the driveshaft without its protector. • Never cross over the driveshaft while it is coupled. • Use, maintain or repair the coupling according to.	1
23		114290	Identification plate.	1
24		065823/ 824	Machine's side - cod. 065824. Tractor's side - cod. 065823.	1
25		180129	Roll coupling and uncoupling.	1
26		187134	Maintenance.	1
27		187135	Maintenance.	1
28		187138	Transport/ Operating height shims.	1
29		187141	Mechanical jack.	1
30		180127	Flow control valve.	1
31		180122	Maintenance.	1
32 33		087136 087137	Patent Pending	1
34		087195	Reflective triangle	1

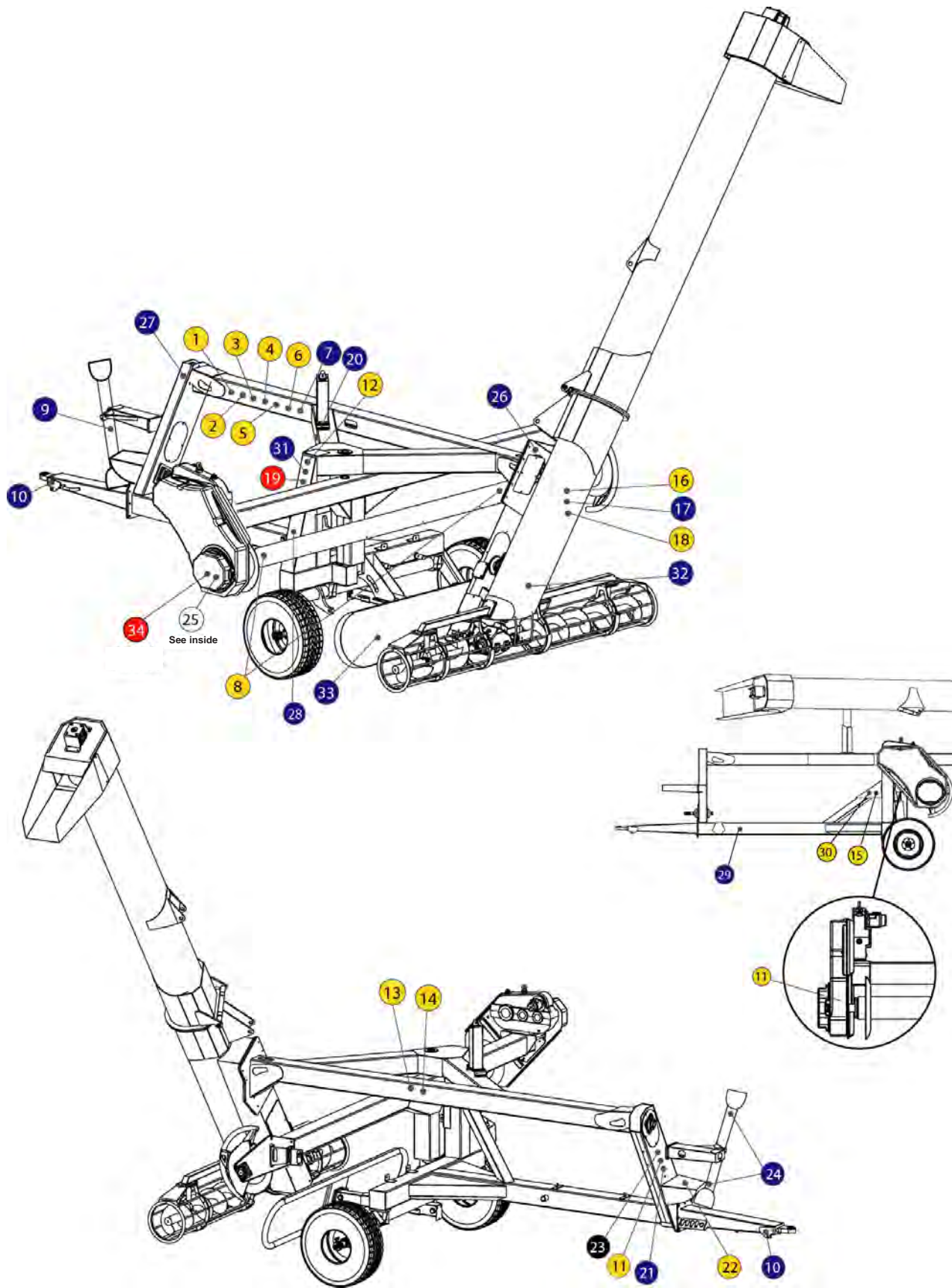

4. RECEIVING THE MACHINE

The grain extractor **AKRON®** modelo **EXG 300** is delivered almost ready for operation. Only a number of verifications related to transport issues must be taken into account upon receiving the machine.

- 1) If the machine is delivered on a truck or other vehicle, special care must be taken to remove all the elements used to fix the machine to the transport vehicle.
- 2) If the machine is delivered in tow, running on its own wheels, the pressure of the wheels must be checked to be at a reasonable level.
- 3) In both cases, the machine's paint and structure must be checked to be free from damages that could have taken place during transport. If that were the case, it would be convenient to assess if the damage could influence the machine's normal operation or if its integrity could be affected in the future.
- 4) All the machine components must be checked to be present and in good operating conditions and all the mechanisms should be operative.
- 5) All the safety guards and protections should be present and in good conditions (e.g., the lifting auger lock pin, the drawbar cover, etc.)

4-a. Identification of your Self-unloading Grain Cart

When ordering replacement parts or requesting technical assistance or information, always provide the following details for product identification purposes:

- Model
- Mass (kg)
- Serial #

This information is engraved on the identification plate, which is located as shown in Figure 4.1 above.

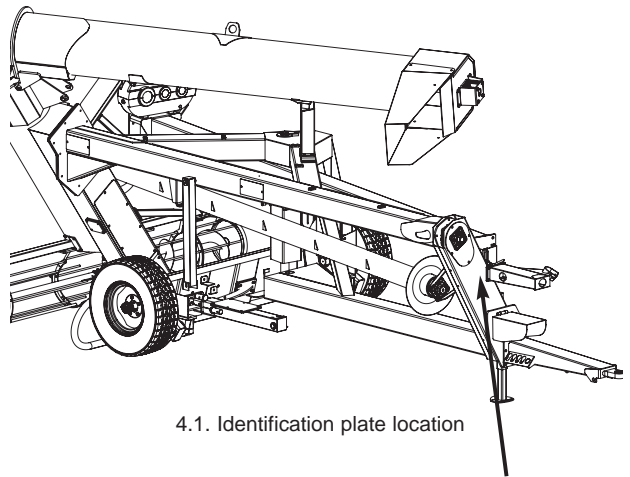

4.1. Identification plate location



Please fill in your machine's data here for your records:

MODEL:
MASS (KG):
SERIAL #:

NOTA: The data, specifications and illustrations in this manual are based on the information available at the time it was written.

Due to the continuing improvements in the design and manufacture of **AKRON®** products, **MICRÓN FRESAR S.R.L.** reserves the right to modify components and/or specifications without prior notice.

Figures are only for illustration purposes, no measures should be taken on the drawings.

4-b. Contact Information

Should you need any further explanation regar-

ding the contents of this manual, please contact us:

Micrón Fresar S.R.L.

Rosario de Santa Fe 2256

X2400EFN - San Francisco (Córdoba)

ARGENTINA

Tel.: ++54 3564 435900 (rollover lines)

Toll free 0 800 333 8300 (in Argentina)

e-mail: export@akron.com.ar

www.akron.com.ar

4-c. Operating Principle

The main functions of the machine are described below, as well as the elements used to perform each of them.

Function	Related component or system
<i>Fastening System</i>	<i>Roll Pins</i>
<i>Grain Bag winding up</i>	<i>Roll driven by a hydraulic motor. Auger driven by a tractor power take-off (PTO).</i>
<i>Grain bag longitudinal cut (slash) during motion.</i>	<i>Cutting blade</i>
<i>End of Bag</i>	<i>Load speed-up Pusher (Grain Pusher System) driven by a hydraulic motor.</i>
<i>Unwinding</i>	<i>Roll driven by a hydraulic motor.</i>

5. PREPARATION AND SETUP

5-a. Operation Requirements

Requiring as little human effort as possible is one of the most important premises for the machine's design, as well as attaining the best possible comfort level for the operator.

To operate the equipment it is necessary to use a tractor with a minimum of 90 HP. Of this vehicle, both its 540 rpm power take-off (PTO) and its oleo-hydraulic system are used, the former for driving the grain augers and the latter mainly for winding up the grain bag. This way, the tractor's traction system remains free, which avoids an excessive wear of the clutch.

Special care must be taken not to use a tractor with a power rating far greater than the recommended figure, and the front wheels should be plain, not studded. Pulling a heavier tractor would cause excessive efforts on the extractor's structure and components.



WARNING: Maximum transport speed 30km/h (19 mph).

5-b. Position changes

The **AKRON EXG 300** mechanical grain extractor can be set in two possible configurations: an operating position and a transport position. The transport position allows the machine to be taken in tow by a pick-up or tractor, compl-

ying with the maximum transportation width allowed.



WARNING: Do not travel on the machine

In the following figure, the main features of both positions can be compared. It can be observed that during transport position the lifting tube is folded and the roll is practically parallel to the chassis.

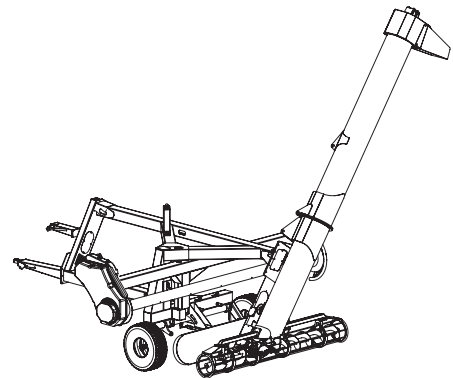

Figure 5.1: Operating position

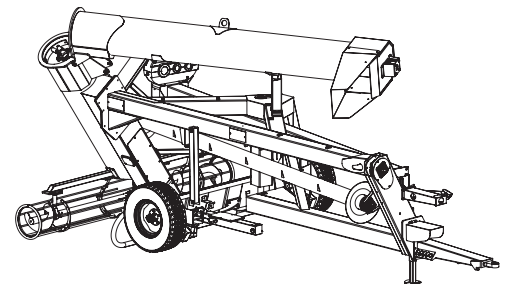
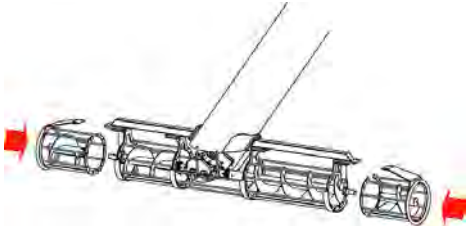
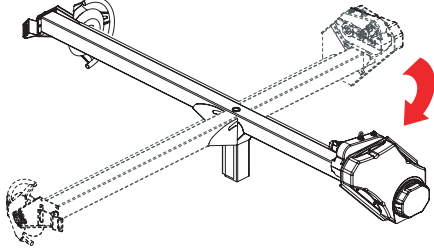

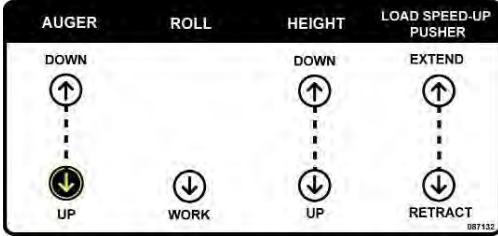
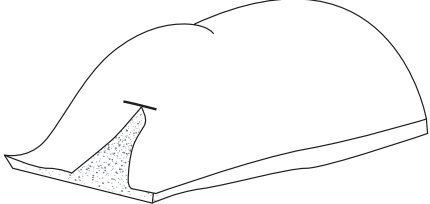



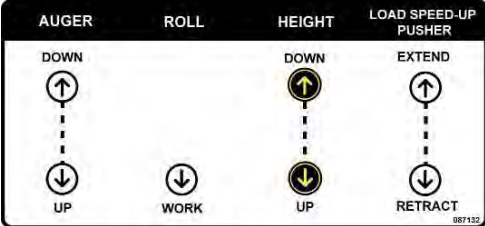



Figure 5.2: Transport position

Change from Transport Position to Operating Position		
Instruction	Action	Obs.
Link the extractor to the operating vehicle. Then, connect the hydraulic circuit together with the power take off.		
Once the machine has been coupled to the tractor, place the mechanical legs into transport position.		

Instruction	Action	Obs.
<p>Take the sweep auger ends from transport position and place them into working position, taking into account the turning direction.</p>		
<p>Unhook the roll by pulling up the latch located at the front part of the chassis, and make it turn until reaching its transverse position; put the supporting arm down in order to lock it.</p>		<p> Warning Avoid hand crushing when turning the roll into operating position.</p>
<p>Remove the lock pin of the superior tube support and activate the "Auger" hydraulic control until the tube is completely unfolded.</p>		
<p>Cut the bag manually and open the cut, leaving the grain at sight (as shown in the figure).</p>		
<p>Check that the blade is aligned with the cut made manually in order to continue cutting. Remove the blade cover to start working.</p>		<p> Warning Check that the blade cover protects the blade while the machine is not operating.</p>
<p>Activate the "Roll" control. With the tractor, take the machine backwards, as centered as possible, and hook the bag to the roll by causing the roll to rotate.</p>		<p> Warning Avoid arm crushing while the roll is operating.</p>
<p>Activate the "Height" control to adjust the operating height. Once again activate the "roll" control to start operating.</p>		<p> Warning When operating the mechanical parts, care must be taken so as to avoid injuries used by trapping.</p>

5.c Recommendations to Make Extraction Easier

The bagging machine **AKRON®** model E 9250 FH Y FHH / E 9250 D has the grain extractor **AKRON®** model **EXG 300** as an ideal complement, and the extractor requires some conditions in the layout and preparation of the grain bags.

If a grain bag is prepared next to a wire fence, a 4-metre clearance must be kept, taking into account that the extractor loads a vehicle moving along to the right-hand side from the point of view of the tractor driver.



Figura 5.3 Location of a grain bag in relation to a wire fence

If two or more grain bags have to be placed parallel one to the other, at least 1 (one) metre should be left between them in order to work with room to spare during the extraction. However, the most important precaution is to anticipate that the first bag can be easily accessed from the side where the grain transport vehicle must move.

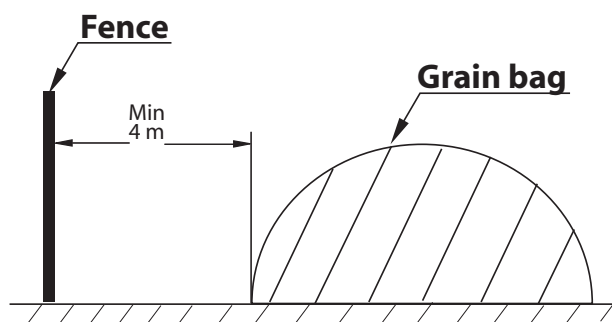

Figura 5.4 Transversal section of two silage bags located parallel to each other.

If the grain bag is closed on its initial end using two pieces of wood or plastic seals, less remaining cereal will be left to remove manually at the end of the extraction process.

5.d Previous Controls on the Machine

Before setting up the machine for the extraction process the following controls will have to be carried out:

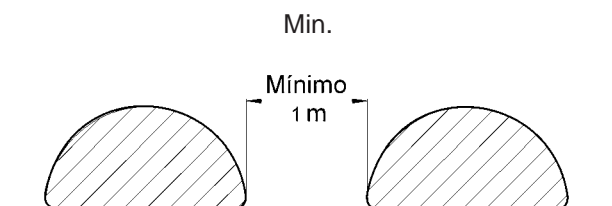
Make sure that all the parts of the machine are prepared according to its operating position, as indicated in Section 4 – “Position changes”

Check the oil level in all the machine's drive and transmission gearboxes. The detail of their components is given in section 9. “Assemblies”. The machine should never be operated if there is not enough oil inside all the gearboxes, since this would result in serious mechanical damage to all these transmission components.

In all cases, if it were necessary to add oil, only SAE 90 must be used. The quality of the oil should never be altered, since this would result in problems for the performance and lifespan of the gearbox components

5.e Machine Layout

Once the extractor is ready in its operating position, it must be placed facing the grain bag in the following way:

1) Align the extractor with the tractor and the grain bag as shown in the figure. These three elements should be as centred and aligned as possible, since this will make the extraction operation easier.

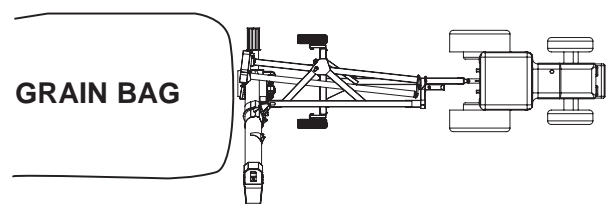

Figure 5.5 Implements alignment

2) Remove the lock pin that keeps the lifting auger attached to the cassis. To prevent this pin from getting lost during the machine operation, it is highly advisable to put it in the same place (tube support for transport position), which is free at that moment.

3) Make sure that the hydraulic switch valve is in the “Auger” position.

3) Activate the "Auger" control.

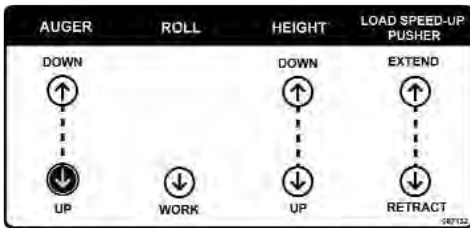

Figure 5.6 Switch valve lever into "TUBE" position.

4) Clear the area below the tube.

5) Lift the tube to its operating position using the tractor's hydraulic system. Check that no person or equipment interferes with the tube in order to prevent dangerous trapping or hitting risks.

6) 6) Activate the "Roll" control when it is necessary to start operating.



WARNING: During operation and transport, keep away from and avoid travelling on the machine.

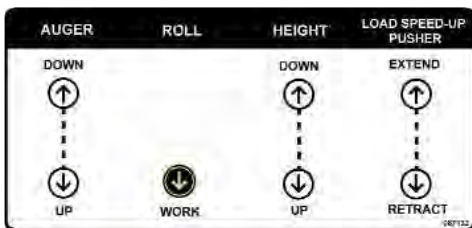

Figure 5.7 Switch valve lever into "ROLL" position.

5-f. Grain Bag Preparation

If it is possible to choose, it is always more convenient to start extracting grain from the end of the grain bag where the storage was finished, since there is enough bag left in this end to fix to the machine's roll. If this option is not available, the operation can also be started from the initial end of the grain bag (see the paragraph 5-b. "Recommendations to make extraction easier").

In both cases, starting from the initial or final end, the grain bag has to be opened as explained below. However, when the extraction starts from the initial end, some grain will have to be removed manually until enough grain bag material is left to fix to the extractor's roll. Follow the instructions given in title 6-e. "Extraction at the end of the grain bag" for manual grain extraction

1) The bag must be opened with extreme care, since any longitudinal slash on the bag's top, the most stretched part of it, could result in the bag opening completely. To avoid such risk, it is advisable to work according to the following procedure:

1.1) Make a short transversal cut, about 20 cm long, about 2 m from the end of the bag. This cut will be more or less at the same height as the extractor's cutting blade.

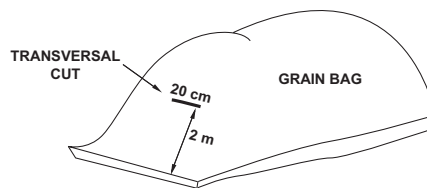

Figure 5.8 Bag transverse cut

1.2) From the middle of the previous cut, slash the grain bag longitudinally up to its end.

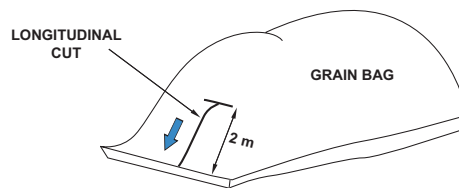

Figure 5.9 Bag longitudinal cut

1.3) Open this last cut to the sides, so that the cereal shows.

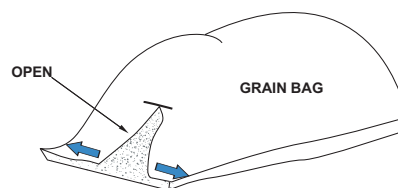

Figure 5.10 Bag opening

2) If there is not enough material to fix the grain bag to the extractor's roll, it is convenient to extract some of the cereal manually, using shovels, until enough plastic is available. Most of the times, this operation will be unavoidable when the extraction starts from the same end where the storage was started.

3) Make sure there are no people or gear around the area in order to avoid any kind of damage. Reverse the machine using the tractor until the cereal starts to cover the horizontal augers. It is important to avoid exerting too much pressure

on the cereal mass, since this may result in excessive, unnecessary efforts on the extractor.

4) Make sure that the machine's cutting blade is aligned with the cut previously made by hand. The cutting blade's cover will have to be lifted to this effect.



WARNING: Ceck that the cutting blade cover protects the blade while the machine is not operating.

Flow Control Valve

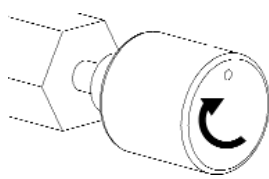

figure 5.11 Close (clockwise)

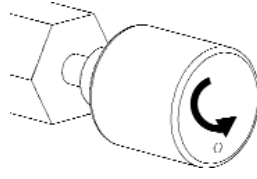

Figure 5.12 Open 1/2 Turn (counterclockwise)

5-g. Final Adjustments on the Machine

First of all, the cardan shaft should not be operated before the grain bag is fixed to the Otherwise, the augers would start moving and the grain bag could get entangled in them. Completely close the flow control valve, and then open it half a turn, that is, 180°.

1) Turn the roll using the tractor's hydraulic system until the roll teeth reach the position shown in the figure 5.13

2) To fix the bag to the roll, both the upper and lower sides of the bag should easily reach the whole breadth of the roll at the height of its teeth.

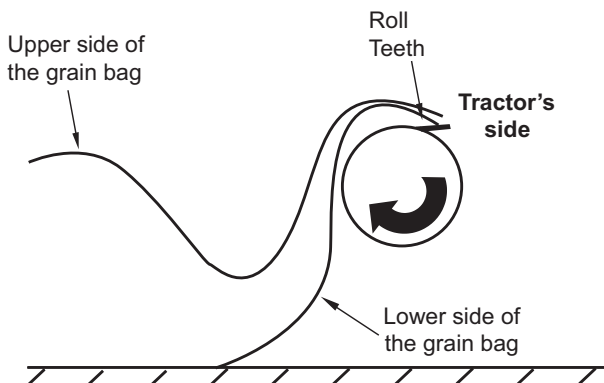

Figure 5.13 - Location of the roll teeth

3) Pierce both sides of the end of the grain bag with each of the roll teeth, as shown in figure 5.14.

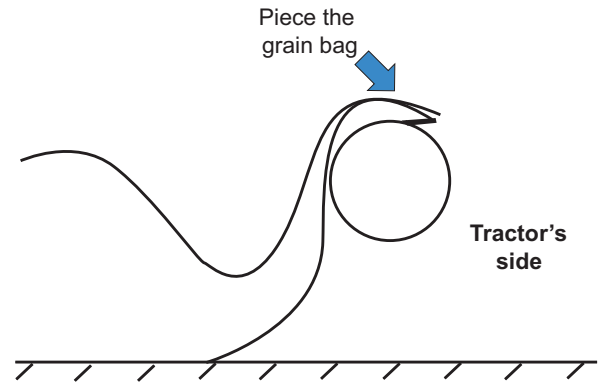

Figure 5.14 – Bag Perforation

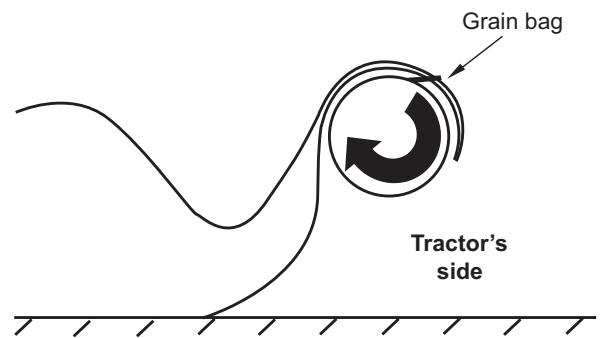

Figure 5.15 secure the bag on the roller teeth.

4) Check once again that the machine's cutting blade is aligned with the cut previously made on the top of the bag. If the cut on the grain bag were not continued normally, the extractor would be subjected to excessive efforts and the grain bag would run the risk of being torn.

If the cutting blade stops cutting, a small transversal (figure 5.16) cut must be made on the grain bag in order to align it with the blade by means of a longitudinal cut as shown in the following figure 5.17.

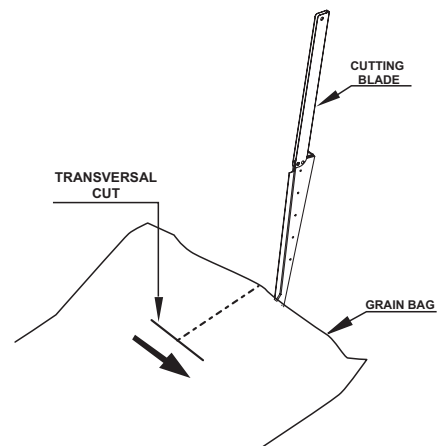

Figure 5.16 - Transversal cut

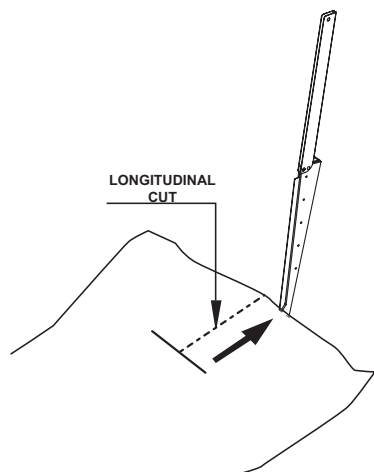

Figure 5.17 – Longitudinal Cut

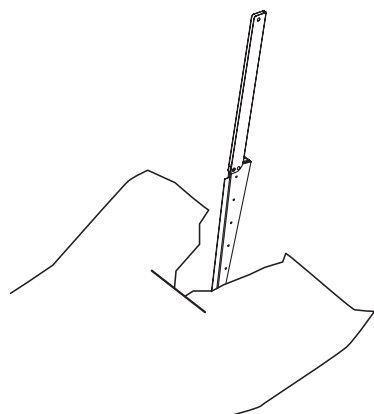

Figure 5.18 Cut Extension

6. SET UP FOR EXTRACTION

6-a. General Comments on the Storage in Grain bags

The storage of dry grain in grain bags is commonplace among rural producers, who regard this system for the conservation of grains to be flexible and economical, since important product commercialisation costs can be eliminated as regards the storage carried out by third parties.

However, the effectiveness of this storage system largely depends on the control performed on the conservation conditions of the grain inside the grain bag, on the operating method used to bag the product and the method used for its extraction. This is why Micrón Fresar S.R.L. includes in the present manual a number of recommended operating rules based on the experience gathered from several rural producers. Besides, an important number of safety warnings are included; they are based on in-depth technical analyses carried out by specialists according to the safety standards in force as regards agricultural machinery of this type.

Therefore, it must be noted that both the order and the details of each one of the explained operations and procedures should be respected, since the success of the extraction operation in itself depends on it, as well as the maintenance of adequately safe conditions for the operators and all the equipment related to the extraction operation. The user is responsible for thoroughly studying the present operation and maintenance manual, paying special attention to all the warnings included in each section and to the contents of paragraph 1.g. "Safety"



Figure 6.1 Grain Extraction



Figure 6.2 Grain discharge into the grain cart.



Figure 6.3 End of Bag.

6-b. Operation Start-up

With the machine and the grain bag prepared as explained in the previous section, the extraction can be started, taking into account the following steps:

1) The following figure shows the layout of all the equipment involved in the extraction process.

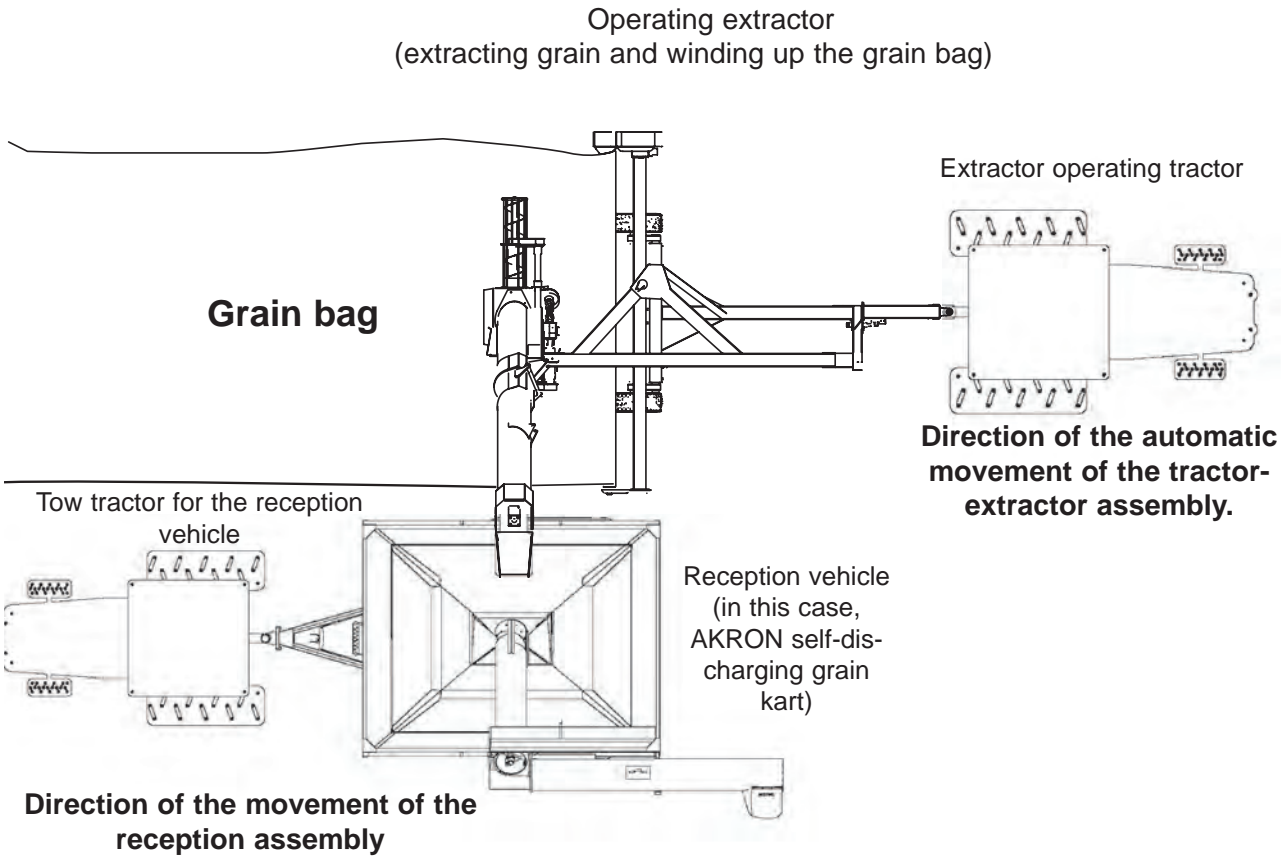

Figure 6.4 – Implements Arrangement

2) Make sure that the extraction tube's outlet is located over the vehicle where the grain is to be loaded.

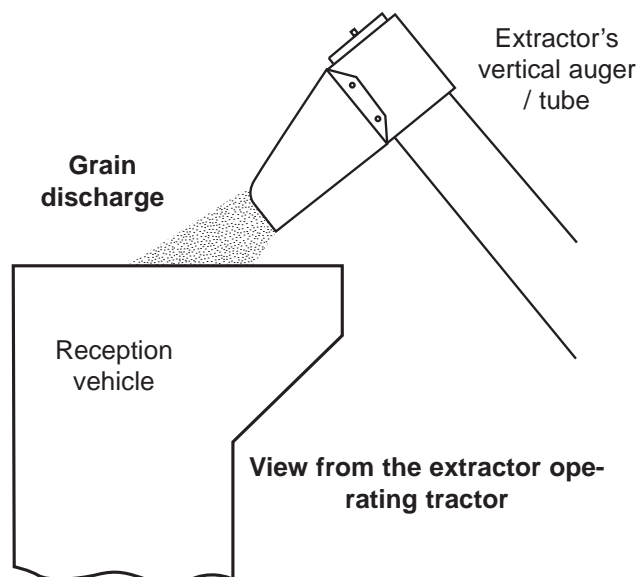

Figure 6.5 – Extraction tube position

- 3) Activate the cardan shaft, slowly at the beginning. This way, the cereal starts to flow upwards. Gradually increase the speed until it reaches 540 rpm on the cardan shaft.
- 4) Make sure that the tractor is not geared and that the hydraulic system is ready to operate.
- 5) With the cardan shaft already turning, hydraulically activate the traction roll in the direction given by the arrow shown in the figure. Using the flow control valve, gradually increase the speed until a reasonable rate is reached (remember that by this time the machine has started moving, tugging the tractor behind it). The idea is to work at a speed high enough to reach a good efficiency, but not excessive, since this would result in the cereal getting trapped inside the bag as it is wound on the roll. The following figure shows an ideal situation, where the cereal level stays invariable inside the bag.



WARNING: Do not stand in the machine pathway while this moves forward during operation. Do not open or remove the covers while the machine is operating.

- 6) Increase the cardan shaft speed up to 540 rpm. To prevent the grain from getting crushed and the augers from wearing out prematurely, do not work at speeds higher than this.
- 7) Make sure once again that the machine's cutting blade is still opening the bag following the original cut. If it was necessary, make a new cut, always transversally (see item 5 within title 5-f. "Final adjustments on the machine").

6-c. Operation Parameters

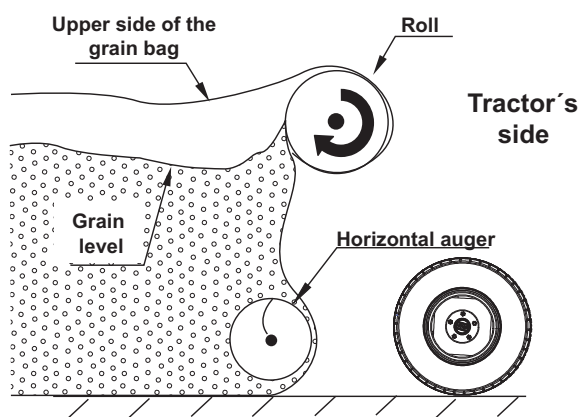

Figure 6.6 – Cereal inside the grain bag

- 1) As the extraction is carried out, the machine's feed speed can be adjusted using the flow control valve. This valve operates directly on the roll's winding speed, and consequently varies the speed with which both the tractor and the extractor move. Every time the speed has to be adjusted, it must always be done gradually, avoiding sudden variations that could overload the hydraulic system.

- 2) During the machine's normal operation, a small "mound" or pile of cereal is formed under the roll. The upper part of it, in the centre, must never be above the roll's height. If this happened, some grain would get trapped inside the bag as it is wound onto the roll. This situation is corrected by opening or closing the flow control valve, thus increasing or reducing the roll's speed.

- 3) The roll's height (h) over the ground must be enough to avoid the accumulation of an excessively large "mound" under the roll. Otherwise, the bag may probably be torn by the transport support, in the rear part of the machine.

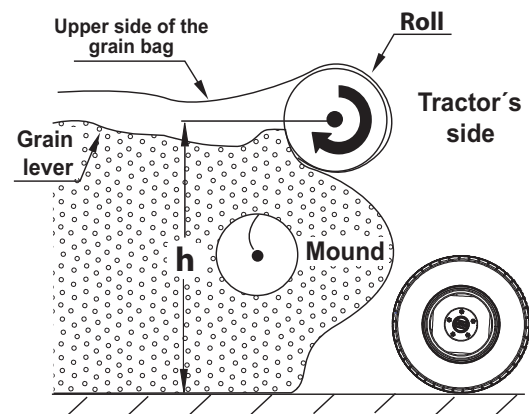

Figure 6.7 - Wrong Height

6-d. Protection against Overloads

In the event the machine was exposed to an excessive effort, it may cause the towbar s to cut (cardan shaft).

These components should never be modified under any circumstances, since they guarantee the machine's good condition and correct operation. The breaking of any of these fuses definitely indicates that the machine was subjected to an extraordinary effort. If these bolts break repeatedly, research should be carried out to determine the causes.

In order to reestablish the transmission, replace the broken bolt with another one according to the following table:

Walterscheid driveshaft

Size	Grade	Tipo	Surface protection	Quantity
M8X1.25X60	8.8 DIN -ISO 931-960	CHexagonal head	Zinc- or cadmium- plated	1

Bondioli & Pavesi driveshaft

Size	Grade	Type	Surface protectionl	Quantity
M10x1.5x50	8.8 DIN -ISO 931-960	Hexagonal head	Zinc- or cadmium- plated	1

Such efforts could probably be caused by the following conditions, which must be specially avoided:

- Immobilized Tractor.
- Articulated tractor.
- The tractor's steering wheels turned up to their maximum limit. This situation turns them into an "anchor" that tends to immobilise the tractor together with the extractor.
- The roll was turned without extracting any cereal.
- The feed speed is higher than the one needed by the cereal to flow through the augers.

6-e. Interruptions during Extraction

If it were necessary to bring the extraction to a halt, for example once a wagon or lorry is full, the following instructions should be followed:

- 1) ALWAYS turn off the hydraulic system first (this stops the roll's rotation) In order to avoid damages due to the effects of inertia, the tractor driver should be ready for the tractor-extractor assembly to stop as soon as the hydraulic system is disconnected.
- 2) Only then let the augers work for a few seconds so that the bag is decompressed. This way, overloads during restart will be avoided.
- 3) Finally, after this short time, the cardan shaft can also be stopped.

It is very important to follow always the given order for this procedure, since otherwise the bag would continue to be wound without cereal extraction, which would cause damage and / or breakdowns to the machine.

To restart the extraction process, the order of the instructions is exactly the other way round, that is, operating first the augers and last the hydraulic system. This way, the cereal is removed to decompress the bag, and this makes it easier for the machine to start moving again.

6-f. Extraction at the End of the Bag

It is important to reach the end of the bag with the machine working as centred as possible.

- 1) When reaching to the end of the bag (two last meters), it is necessary to lower the roll rotation speed.
- 2) Activate the "Load speed-up Pusher" control to locate the pusher as close to the horizontal augers as possible and be able to accumulate the grain near the augers.
- 3) Leave the machine to move forward until fully breaking the grain bag so that there is no more than 80 Kg of grain left.



Figure 6.8 End of Bag.

6-g. Unwinding the Bag

The extractor includes a system to uncouple the roll located on the inner side of the reduction gearbox. The following pictures explain its operation. Stop the tractor and remove the key before working inside the machine or on top of it in order to prevent serious accidents from happening.

This way the roll can rotate freely, which allows the grain bag to be unwound just by moving the tractor forward. If it were necessary, the grain bag should be held by some appropriate means while it is being unwound.

The unwinding process is exactly the same if cereal is extracted from only part of a bag. The only difference is that the remains of the bag must be used to seal it back, always caring for cereal conservation.

In order to disengage the roll, open the clutch protection cover. (Fig 6.9).



Figura 6.9

Pull out the clutch handle (Fig 6.10).

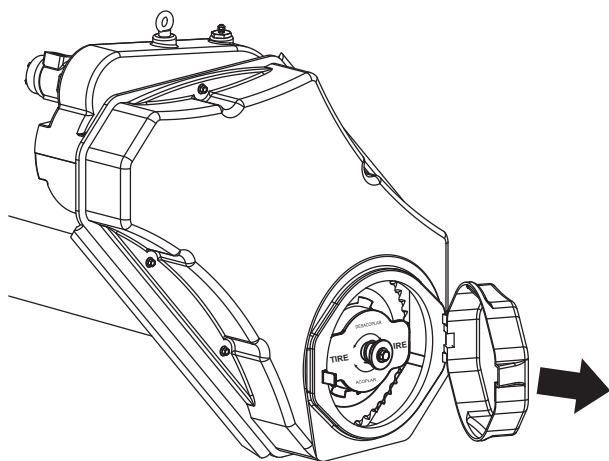

Figura 6.10

Turn the clutch handle until the roll is disengaged (Fig 6.11).



Figura 6.11

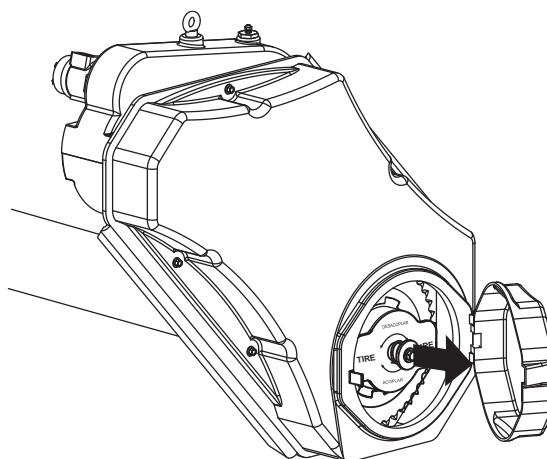

WARNING: Before working on or inside the machine, stop the tractor, and take out the key to avoid serious accidents.

7. MAINTENANCE PROGRAM

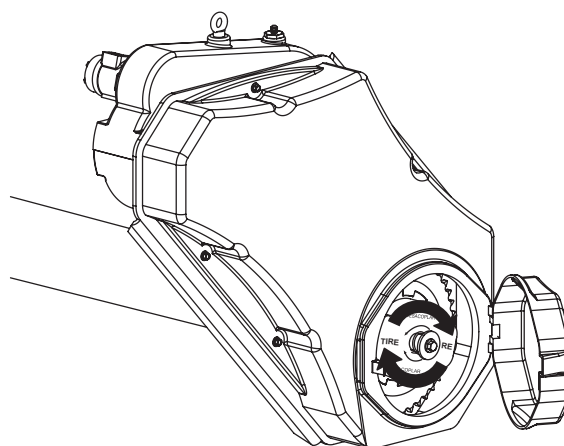
Due to the simplicity of this machine's mechanisms, the only necessary maintenance tasks are the ones detailed below. They are based on a normal machine operation.

7-a. Maintenance Schedule

Maintenance tasks that should regularly be performed are detailed in the attached tables. The effectiveness of the proposed maintenance program depends on the written records of every single activity performed on the machine.

Frequency: daily or before beginning any working day

Condition to verify	Normal situation	Correction method
General machine condition.	Free movements in general, reasonable cleanliness of the main components.	Eliminate the causes of possible restrictions imposed on the movements; remove any dirt that could hinder the machine's operation.
Condition of the vertical auger and horizontal augers	Free from obstructions or excessive dirt	Eliminate possible obstructions or dirt located inside the tube or on the horizontal augers
Tyre pressure	Between 35 and 40 lb/in ² (2,5 and 2,8 kg/cm ²).	Adjust tyre pressure.
Safety Lights.	Correct operation of the safety lights.	Change of the lamp or repair on the circuit, as appropriate.

Frequency: Weekly

Condition to verify	Normal situation	Correction method
Condition of hydraulic circuit hoses and tubes	Hoses and tubes without leakages or serious wear	Change the defective element

7-b. Maintenance after Receiving the Machine

After some 50 hours of continuous operation, it is essential to re-tighten all the machine's screws using the following torque values recommended for SAE grade 5 zinc-plated screws:

Size	Torque [kgm - N.m	(ft.lb)]
1/ 4" - 20	0.96 - 9,5	(7.03)
5/16" - 18	2.03 - 20	(14.81)
3/ 8" - 16	3.61 - 35,5	(26.29)
7/16" - 14	5.81 - 57	(42.22)
1/ 2" - 13	8.86 - 87	(64.44)
9/16" - 12	12.74 - 125	(92.59)
5/ 8" - 11	17.58 - 172	(127.77)
3/ 4" - 10	31.29 - 307	(227.40)

7-c. Parts breakdown for repairs.

All the extractor movable part breakdowns are detailed in this manual with the related spare part lists.

The user will be able to: disassemble, change, and, at a later time, reassemble each assembly and subassembly included as from page 40 (transmission, rolling system, primary vertical auger, secondary vertical auger, mechanical jack, square drive gearbox, reduction gearbox, load speed-up pusher, hydraulic circuit).

7-d. Lubrication

The use of lithium grease # 2 NLGI 2 is recommended for the lubrication ports and SAE 90 oil is recommended for the gearboxes.

(*) Check chain tension every time chains are lubricated, and correct in any case as necessary.

Part or assembly	Location	Lubrication frequency
Drive Chain – front and rear	Driveshaft	Every 50 hours (*)
Sleeve	Vertical auger hinge End of the hydraulic cylinder operating the vertical auger.	Every 50 hours (*)
Bearings	On the upper horizontal drive shaft End of secondary vertical auger	Every 100 hours (*)
DRIVE GEARBOX Reduction Gearbox	Inside the chassis	Every 300 hours (*)
Wheel hub	Axle	Every 300 hours (*)

It is recommended adjusting the chain after unloading the first two bags.

7-e. Prevention of Wear on Flexible Pipes

Take into account the following items for a better use and care of the flexible pipes included in the machine:

- Visually inspect the hydraulic circuit hoses and accessories related to the flow gate operation and to the folding/unfolding of the auger tube. They should not have leakages. Keep them from touching sharp objects. Do not tread on hoses and keep them from being strangled.
- Check that the helical tape covering the hydraulic circuit is in good condition, since it is meant to prevent fluid from hitting the operator if a pipe brakes.



WARNING: Avoid leakage of fluids under pressure.



IMPORTANT: To grease objects that are at a certain height, use a ladder or any other auxiliary device.

7-f. Tire Change

Complete the following steps:





- 1) Slightly loosen the wheel nuts.
- 2) Lift the machine using a mechanical or hydraulics jacks.
- 3) Once the **grain extractor** has been lifted, install the assembled wheel and the five wheel nuts (Parts List # 8).

Tighten the nuts using a 21-mm hexagonal wrench until a final tightening torque of 9kgm = 90 Nm = 65 lbs. pie.

8. MACHINE TRANSPORTATION AND STORAGE

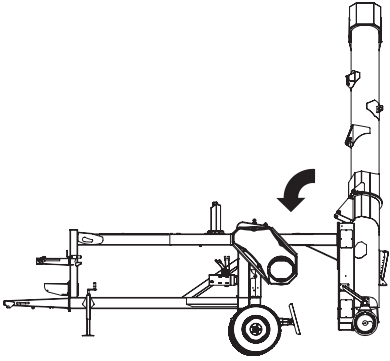
8-a. Preparation of the Machine for Transportation

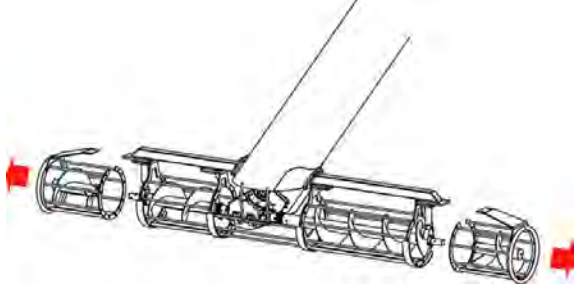
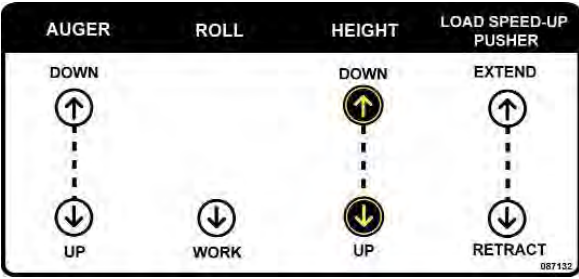
The steps described below should be followed in order to change the machine from its operating position to its transport position.

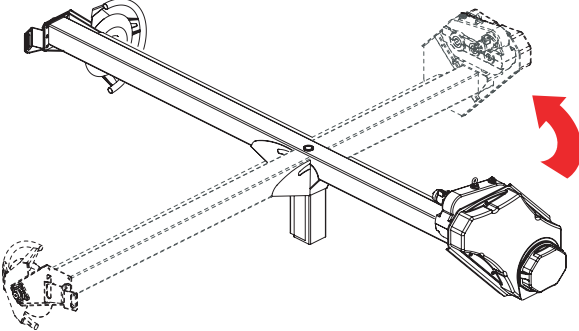
Instruction	Action	Obs.
<p>Take the tube down to its resting position with the tractor hydraulic system and fix the vertical auger with the lock pin. Check that no person or equipment interferes with the tube to avoid trapping or hitting.</p>		 <p>WARNING: Keep away from the machines while operating.</p>
<p>Take the sweep augers ends from their working position and put them into transport position. Put the blade cover..</p>		
<p>Adjust the machine transport position with the "Height" control.</p>		 <p>WARNING In case of transport, place the height shim in the lift cylinder. (Item 8.b).</p>
<p>Lift the supporting arm and turn the roll until reaching its longitudinal position. Pull back the latch located at the front part of the chassis; release it in order to lock the roll.</p>		

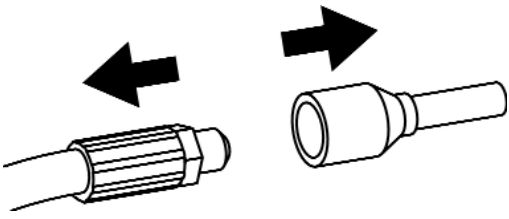
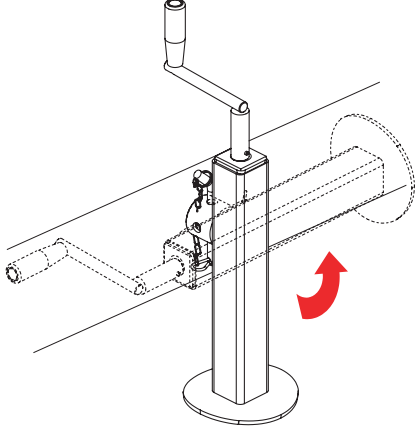
Instruction	Action	Obs.
<p>Disconnect both the hydraulic system and the electrical system. Uncouple the cardan shaft. Disconnect the tow vehicle.</p>		
<p>Couple the pulling vehicle. Adjust the height with the support jack. Connect the electric circuit and put the safety lights into position. The machine is ready for transport.</p>		

8-b. Transportation

The AKRON® model EXG 300 mechanical grain extractor requires no special configuration changes apart from the ones explained in paragraph 8-a. "Preparation of the Machine for Transportation".

Figure 8.1 below shows the machine ready for transport on roads, except for the jack, which should be retracted after connecting the machine to the towing tractor. The towbar hitch, used to tow the grain cart, is also indicated.

IMPORTANT: AKRON® EXG 300 mechanical grain extractor is not designed for road travel. Therefore, **MICRON FRESAR S.R.L.** accepts no liability for accidents or damage that may be caused during transport if the machine is made to travel on roads.



If the user still needs to do this, we recommend consulting national, provincial and municipal safety regulations in force in each region.

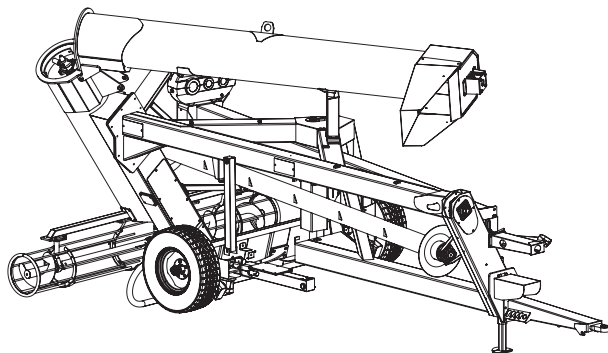

Transport/ Operating height shims

In case of transport/operation, place the corresponding height shim in the lift cylinder.

Figura 8.1- mechanical grain extractor ready for transport on roads

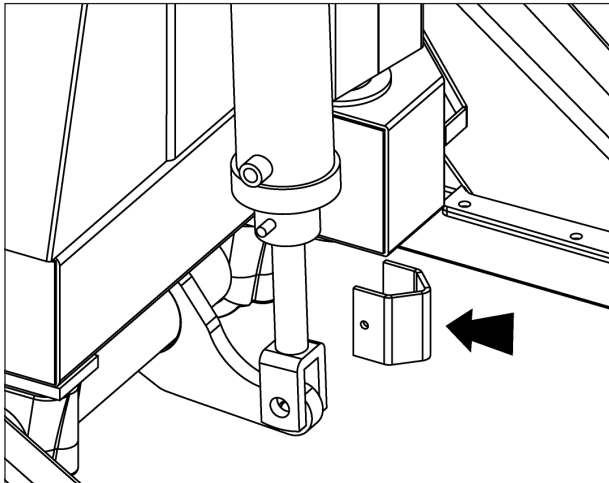

8.2 Operating Height Shim.

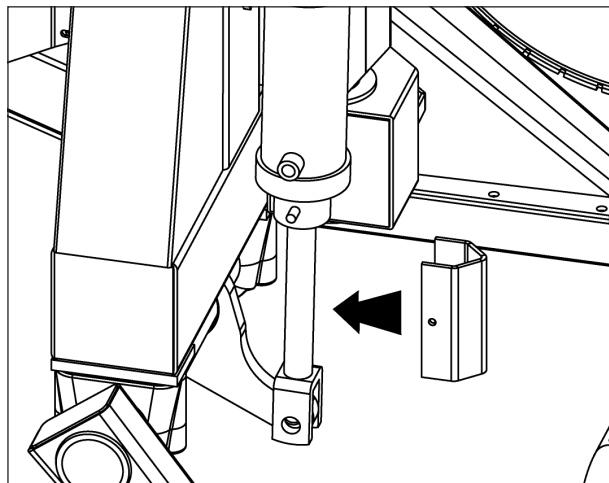

8.3 Transport Height Shim.

ground with a maximum inclination of 8.5°. It is advisable to balance the machine with the hydraulic jacks in order to prevent the machine from sliding down the slope.

Parking Instructions

- 1- Keep the machine coupled to the tractor.
- 2- The jack should be parallel to the ground.
- 3- Remove the height shims from the lift cylinder.
- 4- By activating the lift cylinders, lower the machine until the horizontal augers reach the ground.
- 5- Place the jack perpendicular to the ground.
- 6- Uncouple the machine from the tractor using the help of the jack.

8-c. Machine Storage

Before storing the extractor for several days, it is important to properly grease all movable parts. The machine should be kept indoors in a clean and dry place, preferably with a cover that protects it from the dirt that could gather. If temporarily the machine was kept outdoors, the auger inner cover should be left open.



IMPORTANT: The vertical force applied by the tow hitch over the towing vehicle is around 130 kg. (286 pounds).

8.d. Extractor Parking

The machine is designed to remain firm while parked (uncoupled from the tractor) on solid

9. SPECIFICATIONS

Tare :
2540 kg 5644 lb

Working Capacity:
280 tn/hr

Operation:
67.10 kw (mínimo 90 HP).

Auger Tube:
Ø 430 mm

Recommended operating height:
100/120 mm

Height Adjustment:
Enough to absorb the hitch variations.

Tractor PTO speed:
540 v/min

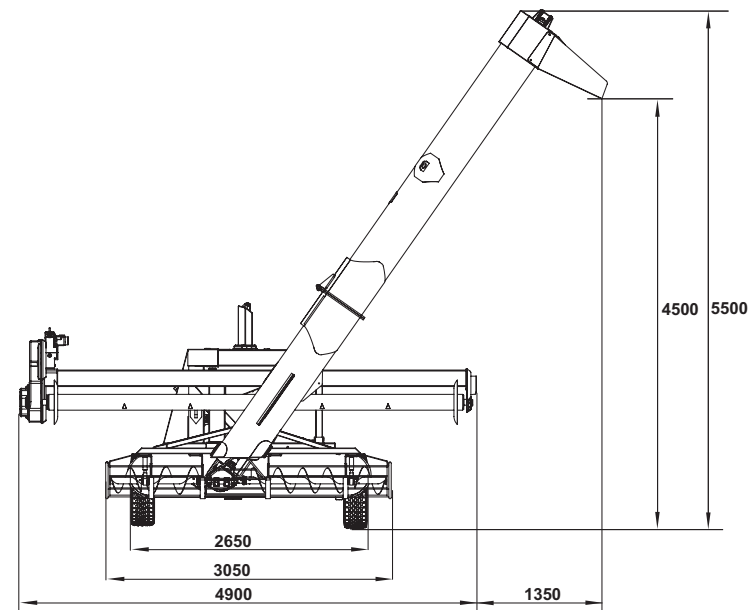
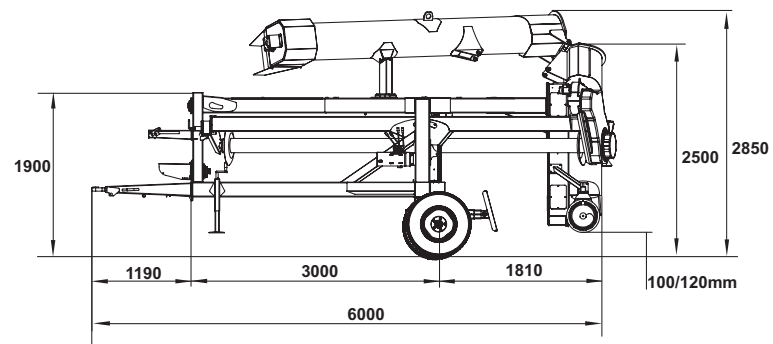

10. PRODUCT DISMANTLING AND DISPOSAL

The following is meant to inform the user about the steps to follow when the lifespan of the machine, of its fluids or components comes to an end. Dismantling and disposal instructions are included.

- Metal parts or assemblies replaced or modified for particular reasons such as corrosion or wear should be properly disposed of. They should be sent to scrap storehouses or foundries where they can receive an adequate treatment. It is essential to wear personal protective equipment (safety gloves) when handling sheet steel..
- The system fluids which are periodically replaced (non-biodegradable hydrocarbon-derived oils and greases) should not be disposed of in the soil or in water courses, since this would result in environmental pollution. Up to now, the most usual application for these wastes is to use them as fuel for vapour generators (boilers) burning fuel-oil. They may also be burnt in special waste-burning kilns. Otherwise, they should be delivered to companies authorized to handle and transport them.
- Some practical use may be found for tires when they are removed from the machine after becoming worn out. Otherwise, they should be taken to a tire-recycling centre for their medium- or long-term integration into the ecological cycle according to national, provincial and municipal regulations in force.

11. GUARANTEE TERMS

Micrón Fresar S.R.L guarantees the **AKRON® EXG 300 mechanical grain extractor** for a one-year period since the date in which the new unit is delivered to the customer.

If the **AKRON® EXG** grain bag unloader is used at storage sites and/or for machine rental, the guarantee period will be limited to 90 days from the delivery date.

This guarantee covers defects in materials used to manufacture the machine, provided that the grain bag unloader has been properly operated. The operating procedures considered appropriate are those described in this manual.

This guarantee does not cover the following:

Damages or failures as a result of improper operation or lack of machine maintenance that may occur during transport, operation, or parking from the delivery date.

Tires own guarantee.

Normal wear of parts due to their use. Their replacement is part of the preventive maintenance. **(Page 69)**

Micrón Fresar S.R.L is not responsible for any repair made by third parties, or damages resulting from this cause.

Micrón Fresar S.R.L. reserves the right to modify specifications and designs without previous notice and without the obligation to implement these changes in the machines already delivered.

For a good machine performance, **Micrón Fresar S.R.L** recommends meeting the following conditions:

Dry, clean grain (13.5% moisture content at reception),

Undamaged bag (without mechanical damage resulting from hail, stubble or animals).

It has been noticed that the machine performance decreases when storing hulled grain since there are different degrees of abrasion. Therefore, some grains will flow less smoothly than others.

Damages caused during machine operation by any person whose abilities are affected or redu-

ced will not be covered.

If the machine is sold by the first owner within the guarantee term validity, this will be transferred to the new owner, provided that Micron Fresar S.R. is advised by written notice. Such guarantee will not be valid if the current owner of the machine (not being the original buyer of the product) has not advised **Micrón Fresar S.R.L** in due time.

The guarantee will automatically become invalid if any of the parts of the machine is modified or replaced by spare parts not provided by **Micrón Fresar S.R.L.** If such replacement or structural modification was urgently necessary, the user must obtain written approval from **Micrón Fresar S. R. L.** to make such changes without affecting these guarantee terms.

In order for the guarantee to come into force, it is an essential condition to submit a request for guarantee repair together with the following information:

Name:

Date in which the damage occurred:

City:

Phone Number:

Machine Model:

Serial Number:

Invoice Number:

12. ALPHABETICAL INDEX

Accessories 7, 24, 35
Auger 8, 11, 12, 13, 19, 22, 23, 24, 25, 27, 29, 35, 38, 42, 44
Ball joint 8, 11, 15, 17, 20, 21, 24, 35
Bearing 35, 38, 40, 42, 44, 48, 50, 52
Blade 9, 12, 16, 17, 18, 35
Box 21, 24, 35, 38, 40, 48, 50, 52
Capacity 29, 35
Chassis 11, 13, 14, 15, 16, 22, 24, 35
Cleaning 23, 35
Contact Information 5, 7, 11, 13, 26, 35
Disposal 6, 31, 35
Dismantling 6, 31, 35
Elementos 5, 7, 16, 21, 24, 35
Extraction 5, 8, 9, 12, 14, 15, 16, 18, 19, 21, 25, 35
Extractor 1, 3, 5, 6, 8, 9, 13, 15, 16, 26, 27, 35, 38
Guarantee Terms 3, 6, 33, 35
Grain Bag 5, 8, 12, 13, 15, 16, 17, 18, 19, 20, 21, 22, 35, 40
Mechanical jack 14, 35, 46
Hose 24, 35
Maintenance 1, 3, 5, 8, 9, 12, 23, 33
Motor 8, 12, 35, 50
Norma 7, 35
Oil 15, 24, 35, 49, 51, 53
Parking: 6, 27, 35
Pictograms 7
Position 29
Receiving 5, 11, 19, 23, 35
Risk 35
Safety 3, 5, 7, 8, 9, 11, 12, 17, 26, 27, 31, 35, 37
Speed 8, 9, 12, 13, 20, 21, 35
Spare Parts 6, 15, 37
Storage 5, 6, 12, 27, 35
Symbol 5, 7, 35
Tractor 8, 9, 12, 13, 14, 15, 16, 17, 19, 20, 21, 22, 25, 27, 29, 35
Transport 5, 8, 9, 11, 12, 13, 20, 21, 25, 26, 29, 31
Towbar 13, 15, 21, 24, 26, 35
Valve 12, 14, 17, 20, 25, 26, 35, 48, 50, 52

13. SPARE PARTS LIST

All the components of the **AKRON® EXG 300** *mechanical grain extractor* are detailed in the following pages. To order a spare part for your machine, do the following:

- Use the attached exploded diagrams, to identify the component/s to be replaced.
- Note the code of each part and, if possible, the name of each assembly.
- Order the spare parts from your nearest **AKRON®** Technical Representative or to **AKRON®** Spare Parts Service (see 13-a. "Information to Obtain Spare Parts"), indicating each part's code and, if possible, the name of each assembly.
- If replacing a part that originally included safety decals, check that these are also present on the replacement part.

13-a. Information for Obtaining Spare Parts

AKRON® Spare Parts Service
Micrón Fresar S.R.L.
Rosario de Santa Fe 2256
X2400EFN - San Francisco (Córdoba)
ARGENTINA
Tel.: ++54 3564 435900 (rollover lines)
Toll free 0 800 333 8300 (in Argentina)
e-mail: export@akron.com.ar
www.akron.com.ar

The nearest **AKRON®** Technical Representative can also be contacted to obtain machine components.

PARTS LIST # 1

TRANSMISSION

#	PART NUMBER	NAME	QTY
1	20.29.87000	DRIVE GEARBOX ASSEMBLY	1
2	27.43.87506	SAFEGUARD SYSTEM BUSHING	1
3	27.39.87237	RIGHT INNER AUGER	1
4	27.43.87519	REAR BEARING SUPPORT	1
5	98.715.117745	NUP 2209 BALL BEARING	1
6	27.43.85586	MAIN SHAFT END Ø 44 (cotter 27.43.85554)	1
7	98.611.177365	SAV 6914	1
8	98.610.174935	SAV 7492	1
9	27.43.85584	SUPPLEMENT LONG BUSHING	1
10	27.39.85590	MAIN DRIVESHAFT	1
11	27.42.87520	INNER AM-45 SUPPORT	1
12	06.41.00145	AM-45 CAST IRON SUPPORT	4
13	27.43.85580	LONG Ø 44 MAIN SHAFT END (COTTER 27.43.85554).	1
14	27.43.85581	SUPPLEMENT SHORT BUSHING	1
15	27.42.85189	REINFORCED AM 45 SUPPORT PLATE	1
16	27.43.85188	SPLINED INLET SHAFT W/CAP (COTTER 27.43.85553)	1
17	27.43.85512	MAIN SHAFT COVER	1
18	25.41.06322	UC 208 PENDULUM ASSEMBLY	2
19	98.755.355540	UC 209 BEARING	2
20	27.39.87219	RIGHT HORIZONTAL AUGER EXTENSION	2
21	27.39.87253	LEFT HORIZONTAL AUGER EXTENSION	1
22	27.39.87502	GEAR BOX SPROCKET Z:19	1
23	98.705.205928	6206 BEARING	2
24	27.39.87516	GEAR WHEEL Z 16	2
25	27.39.87508	CENTRAL SPROCKET Z 19 / Z 16	1
26	27.39.87514	PLATE WITH TENSIONER SHAFT	1
27	27.39.80193	ROLL REDUCTION GEAR BOX CHAIN TENSIONER	2
28	27.39.85568	GEAR WHEEL Z 22	1
29	99.388.100254	ASA 80 1" CHAIN	1
30	99.388.100254	ASA 80 1" CHAIN	1
31	99.388.100254	ASA 80 1" CHAIN	1
32	27.39.80224	HORIZONTAL AUGER COUPLING	2
33	27.39.87243	LEFT HORIZONTAL AUGER	1
34	98.755.35545	UC 209 BEARING	4
35	27.43.87505	SAFEGUARD PLATE	1
36	98.755.255540	UC 208 BEARING	1
37	06.51.00240	AP-40 CAST IRON SUPPORT	1
38	99.388.200158	CHAIN ASA 50-2 5/8" P	1
39	29.39.85567	MAIN TRANSMISSION GEAR WHEEL Ø 45	1
40	98.652.085573	MAIN DRIVESHAFT SUPPORT	1
41	98.780.037800	CROSS ARMS	1
42	27.39.87224	HORIZONTAL AUGER EXTENSION GUARD	2
43	27.39.87201	RIGHT INNER AUGER GUARD	1
44	27.39.87230	MAIN GUARD	1
45	27.39.87202	LEFT HORIZONTAL AUGER GUARD	1

PARTS LIST # 1

TRANSMISSION

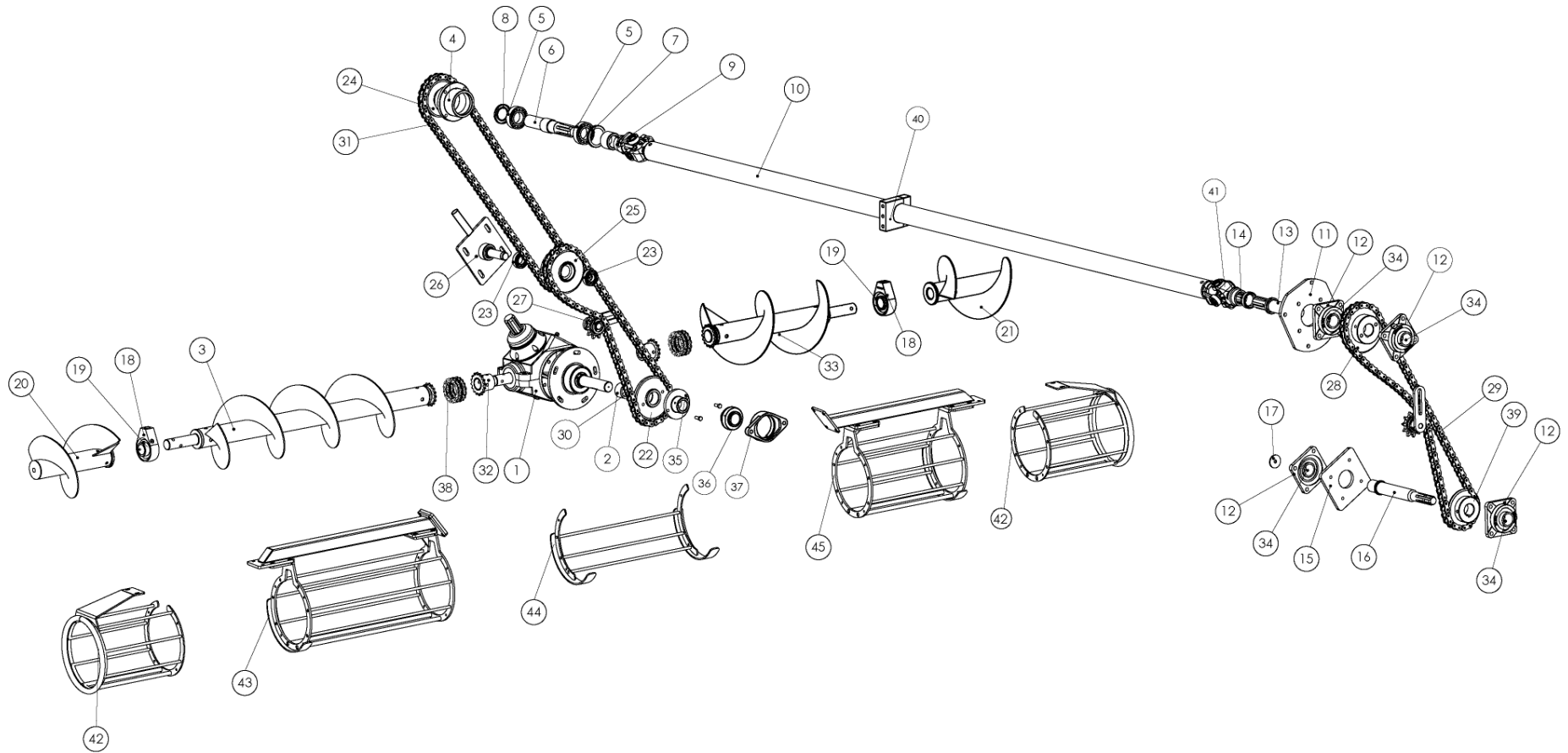

OPTIONAL COMPLETE RICE KIT 27.29.87850

#	PART NUMBER	NAME	QTY
1	27.42.87854	EXTERNAL COVER	2
2	27.42.87851	LEFT SUPPORT COVER	1
3	27.42.87852	INNER COVER	2
4	27.39.87875	AXIAL REINFORCEMENT	1
5	27.42.87850	RIGHT SUPPORT COVER	1
6	27.39.87874	EXTERNAL PROTECTOR	2
7	27.39.87877	AUGER	1
8	27.39.87878	AUGER PROTECTOR	1
9	27.39.87871	PRIMARY PROTECTOR	1
10	27.39.87872	CENTRAL PROTECTOR	1
11	27.39.87873	SECONDARY PROTECTOR	1
12	98.378.080568	" SAUER DANFOSS" ORBITAL HYDRAULIC MOTOR	2
13	06.141.00230	UC206 BEARING HOUSING	1
14	27.39.87879	HANDLE SUPPORT	2
15	27.42.80221	Z 16 P 5/8" GEAR WHEEL	1
16	27.39.87886	CRUMBLER	1
17	27.39.87892	ASSEMBLED COVER	1
18	98.755.255530	UC 206 BEARING	1
19	27.39.87881	PADDLE AUGER MAIN SUPPORT	1
20	27.39.87280	FULL CASE –HARDENED SECONDARY AUGER ASSEMBLY	1
21	27.39.87845	JACKETED TUBE KIT	1
22	27.39.87284	LEFT EXTERNAL FULL CASE-HARDENED AUGER	1
23	27.39.87282	LEFT FULL CASE-HARDENED AUGER	1
24	27.39.87283	RIGHT INNER FULL CASE-HARDENED AUGER	1
25	27.39.87285	RIGHT EXTERNAL FULL CASE-HARDENED AUGER	1
26	27.39.87281	CONJUNTO SIN FÍN PRIMARIO CEMENTADO COMPLETO	1

TERMS OF SERVICE AND EXPECTED PERFORMANCE OF THE EXG 300 GRAIN BAG UNLOADER RICE KIT.

THE RICE KIT HAS BEEN DEVELOPED AND OFFERED TO IMPROVE THE EXG 300 GRAIN BAG UNLOADER PERFORMANCE WHEN UNLOADING RICE FROM THE GRAIN BAG. THIS KIT CAN BE ADAPTED TO WORK WITH **9-FOOT** BAGS THAT ARE IN PERFECT CONDITIONS AND REMAIN OUTSIDE FOR LESS THAN A YEAR.

THE MACHINE SHOULD HAVE **CASE-HARDENED AUGERS** AND A **HYDRAULIC CIRCUIT** ADAPTED TO THIS KIT (FIGURE IN PAGE 10).

UNDER REGULAR CONDITIONS OF GRAIN CONSERVATION IT IS POSSIBLE TO ACHIEVE UNLOADING PERFORMANCES OF **100 TO 110 TONS**. BY REGULAR CONDITIONS IT IS UNDERSTOOD HULLED GRAIN WITH 13 TO 16% OF MOISTURE, LACK OF MOISTURE AND FERMENTED GRAIN IN THE INNER PART OF THE BAG, LACK OF TRACES OF FUNGI AND INSECT ATTACK INSIDE THE GRAIN MASS, AND EVERY PROCESS AFFECTING THE GRAIN FLOW INSIDE THE BAG.

OPTIONAL COMPLETE RICE KIT 27.29.87850

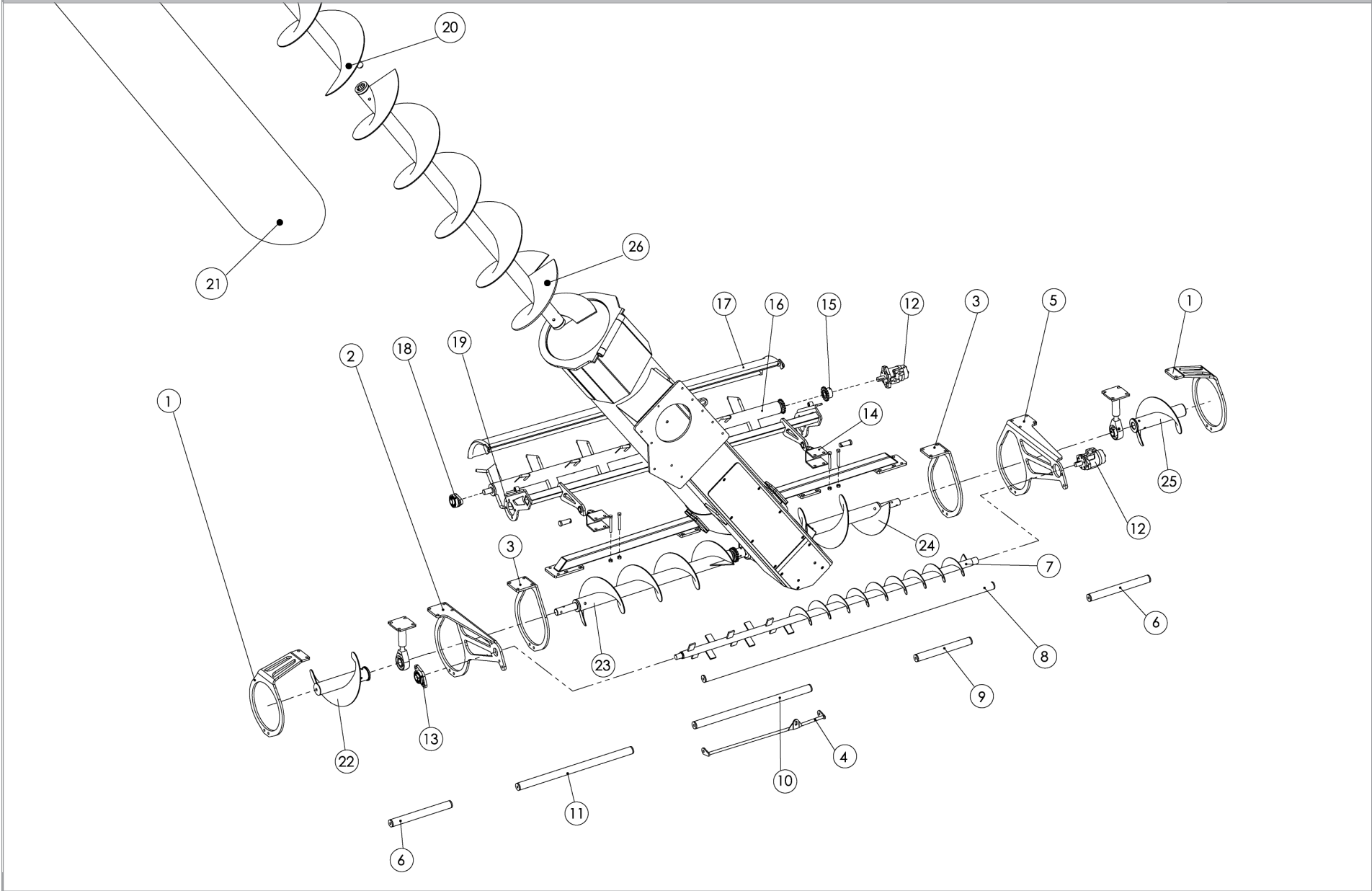

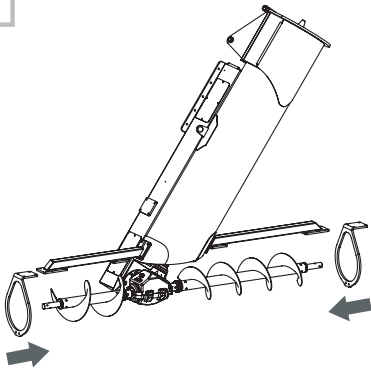
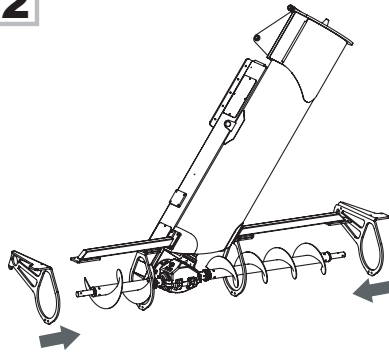
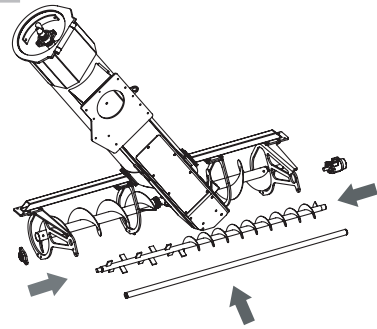
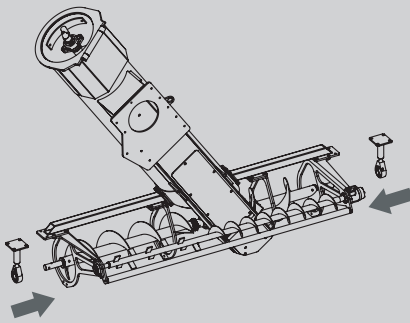
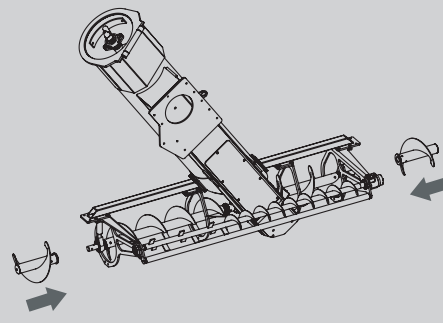
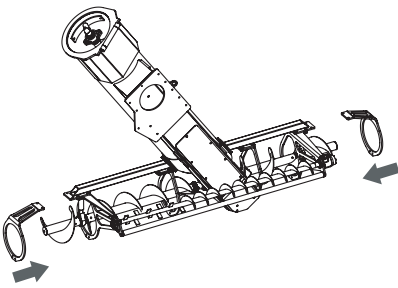
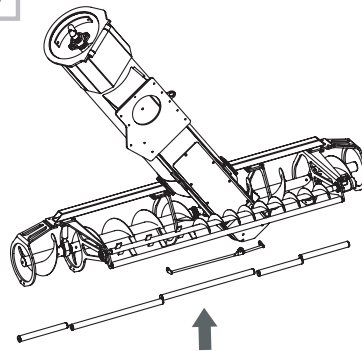
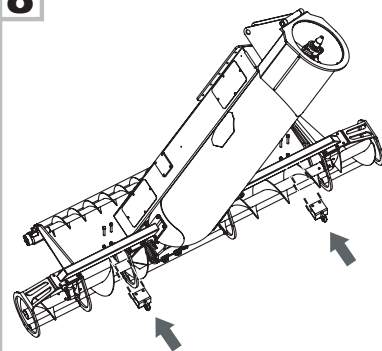
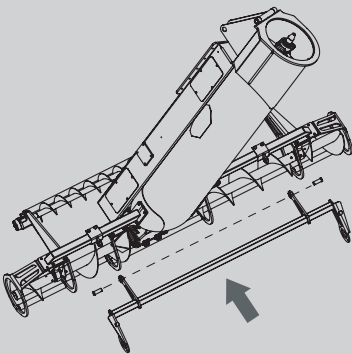
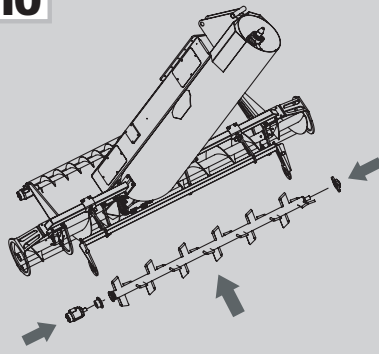
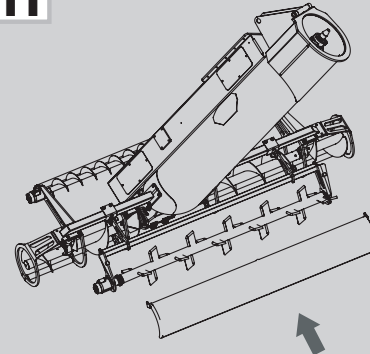
**ASSEMBLIES BELONGING TO THE OPTIONAL COMPLETE
RICE KIT - 27.29.87850****1****2****3****4****5****6****7****8****9****10****11**

ASSEMBLIES BELONGING TO THE OPTIONAL COMPLETE RICE KIT - 27.29.87850

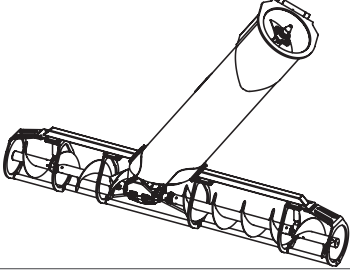
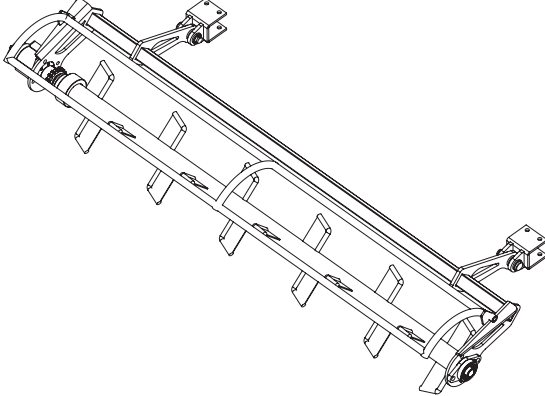
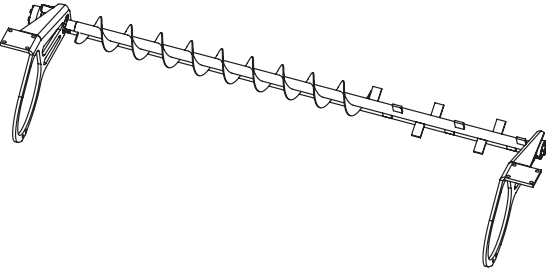
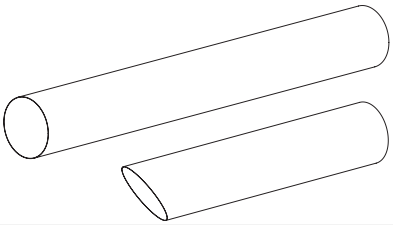
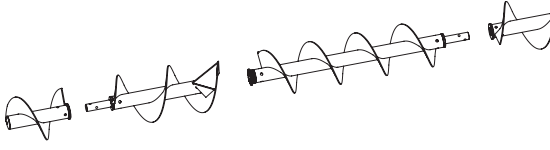
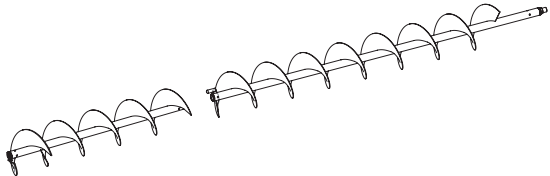
	<p>27.39.87849: FREE PROTECTION KIT</p> <p>98.002.127044 G5 1/2x1 3/4"Rw Hex head screw 98.310.100127 1/2" Grower washer</p>
	<p>27.39.87848: GRAIN STIRRER KIT</p> <p>98.002.079038 G5 5/16x11/2" Hex head screw - Qty:2 98.002.111102 G5 7/16x4"Rw Hex head screw - Qty: 4 98.002.127051 G5 1/2x2" Rw Hex head screw - Qty: 4 98.301.150079 G5 5/16" Rw Hexagonal nut - Qty: 2 98.301.150111 W 7/16" G5 Hexagonal nut - Qty: 4 98.301.150127 G5 1/2" nut - Qty: 4 98.309.100079 5/16" Flat washer - Qty: 2 98.309.100127 1/2" Flat washer - Qty: 4 98.310.100079 5/16" Grower washer - Qty: 2 98.310.100111 7/16" Grower washer - Qty: 4 98.310.100127 1/2" Grower washer - Qty: 4 98.378.080568 100cc Orbital hydraulic motor - Qty: 2 98.380.040090 Ø4x90mm Clip 98.388.120158 Asa 50-2 joint w/clips N° 26 98.755.255530 Uc 206 doble-shielded bearing 98.388.200158 Asa 50-2 P 5/8 chain</p>
	<p>27.39.87847: REAR CASE-HARDENED AUGER KIT.</p> <p>98.002.079038 G5 5/16x11/2" Hex head screw - Qty: 2 98.002.127038 G5 1/2x11/2 Rw Hex head screw - Qty: 4 98.310.100079 5/16" Grower washer - Qty: 2 98.310.100127 1/2" Grower washer - Qty: 4 98.378.080568 100cc Orbital hydraulic motor - Qty: 1 98.755.255530 Uc 206 double-shielded bearing - Qty: 1</p>
	<p>27.39.87845: JACKETED TUBE KIT</p> <p>27.43.87286: Primary tube jacket 27.43.87287: Secondary tube jacket</p>
<p>27.39.87846 COMPLETE CASE-HARDENED AUGER KIT</p>	
	<p>27.39.87282: Left full case-hardened auger 27.39.87283: Right inner full case-hardened auger 27.39.87284: Left external full case-hardened auger 27.39.87285: Right external full case-hardened auger</p>
	<p>27.39.87280 Full case-hardened secondary auger assembly 27.39.87281 Full case-hardened primary auger assembly</p>

HEAVY USE KIT

#	PART NUMBER	NAME	QTY
1	27.39.87551	Z22 INLET SPROCKET	1
2	27.39.87553	CENTRAL SPROCKET ASSEMBLY	1
3	27.39.87560	DOUBLE TENSIONER	1
4	27.39.87563	Z 16 UPPER ASSEMBLED SPROCKET	1
5	27.43.87567	SECONDARY CHAIN	1
6	27.43.87566	PRIMARY CHAIN	1
7	27.43.87568	THIRD CHAIN	1

HEAVY USE KIT

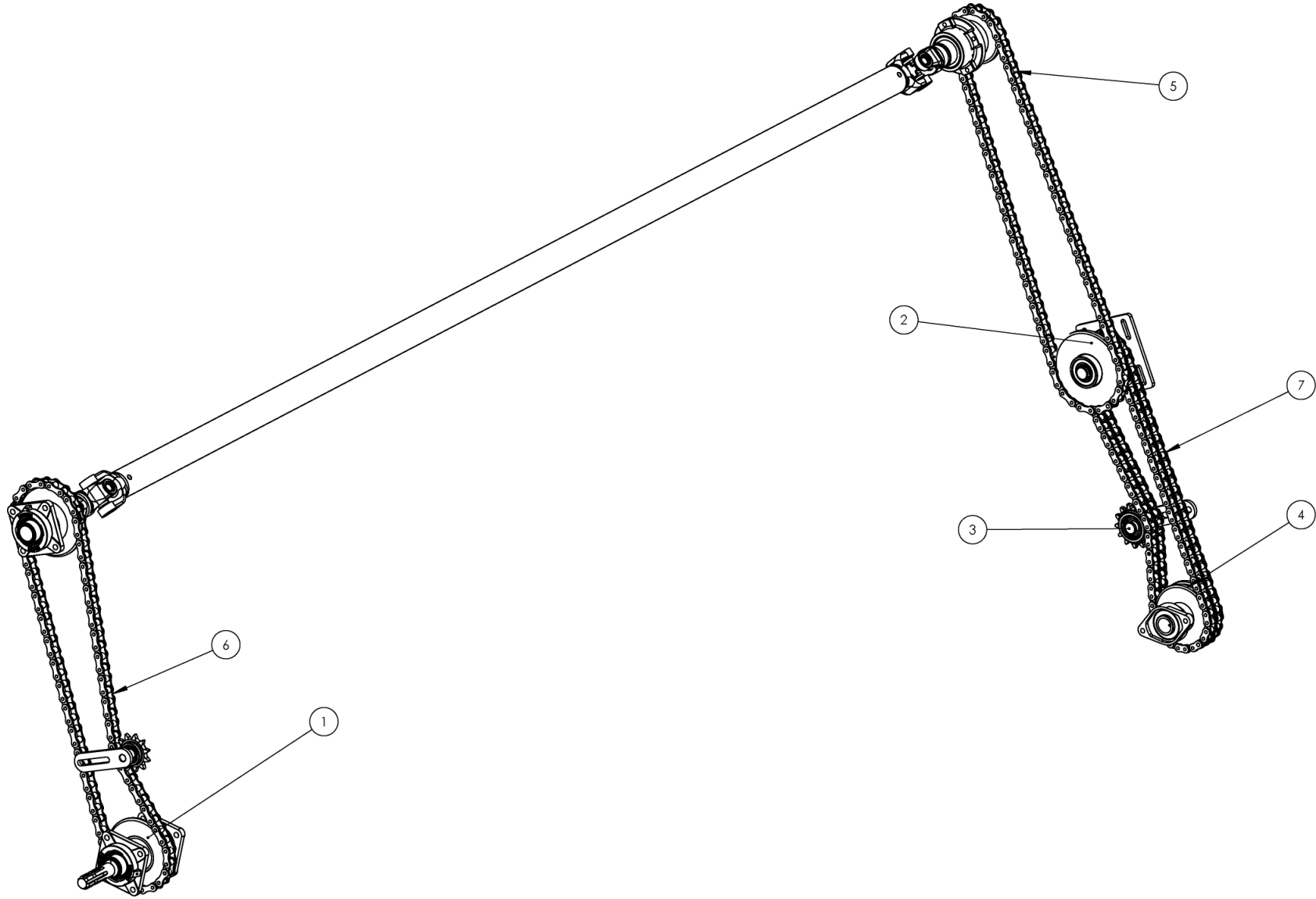

PARTS LIST # 1**OPTIONAL 10' KIT**

#	PART NUMBER	NAME	QTY
1	27.39.87954	LEFT HORIZONTAL AUGER EXTENSION 10'	1
2	27.39.87951	RIGHT HORIZONTAL AUGER EXTENSION 10'	1
3	27.39.87956	HORIZONTAL AUGER EXTENSION GUARD 10'	2
4	27.29.87950	GRAIN BAG LEADER	2
5	27.39.87973	ROLL LOCK	1

COMERCIAL ITEMS FOR 10' KIT

98.002.127044: G5 1/2x1 3/4"RW HEX.-HEAD SCREW - QTY: 6

98.309.100127: 1/2" FLAT WASHER - QTY: 6

98.310.100127: 1/2" SPLIT LOCK WASHER - QTY: 6

98.002.158044: G5 5/8x1 3/4"RW HEX.-HEAD SCREW - QTY: 2

98.309.100158: 5/8" FLAT WASHER - QTY: 2

98.310.100158: 5/8" SPLIT LOCK WASHER - QTY: 2

PARTS LIST # 1

OPTIONAL 10' KIT

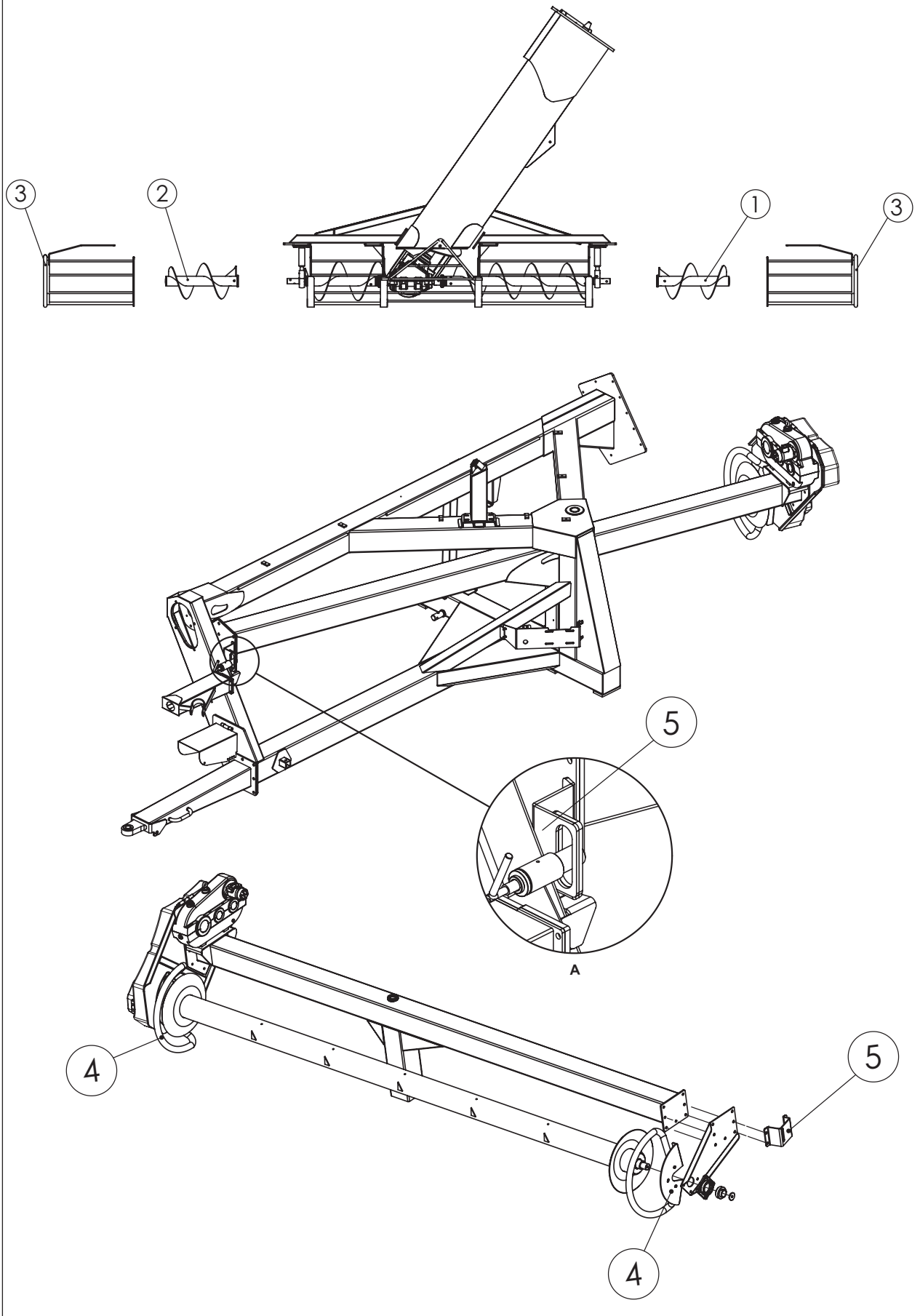

PARTS LIST # 2		GRAIN BAG WINDING SYSTEM	
#	PART NUMBER	NAME	QTY
1	98.002.127089	G5 1/2" x 3 1/2" RW HEX.-HEAD SCREW	1
2	98.309.101127	1/2" ZINC PLATED FLAT WASHER	1
3	27.43.85458	STOP WASHER	1
4	98.342.085560	SPING	1
5	27.43.85457	STOP BUSHING	1
6	27.52.85454	CLUTCH COUPLING HANDLE	1
7	27.52.85453	SPROCKET	1
8	98.077.095019	W3/8" X 3/4" FLUSH HEAD ALLEN SCREW	2
9	27.43.85456	TOWING	1
10	27.43.85462	HANDLE RING	1
11	27.43.85459	12X12X44 COTTER PIN	1
12	27.52.85452	INTERNAL GEAR WHEEL	1
13	27.43.85461	Z: 45 - ASA 80 GEAR WHEEL	1
14	27.52.85451	GEAR WHEEL TOWING	1
15	27.43.85460	Ø 69.8 WASHER	1
16	27.43.85455	ROLL GEAR WHEEL BUSHING	1
17	06.41.00150	UC 210 BOX	1
18	27.43.85463	ROLL TOWING SHAFT	1
19 a	27.43.80407	GRAIN BAG WINDING ROLL (9')	1
19 b	27.43.86407	GRAIN BAG WINDING ROLL (10')	1
20	27.43.80415	ROLL END INTERNAL BUSHING	1
21	06.41.00145	AM-45 CAST IRON SUPPORT	1
22	98.755.355545	UC 209 BEARING	1

PARTS LIST # 2

GRAIN BAG WINDING SYSTEM

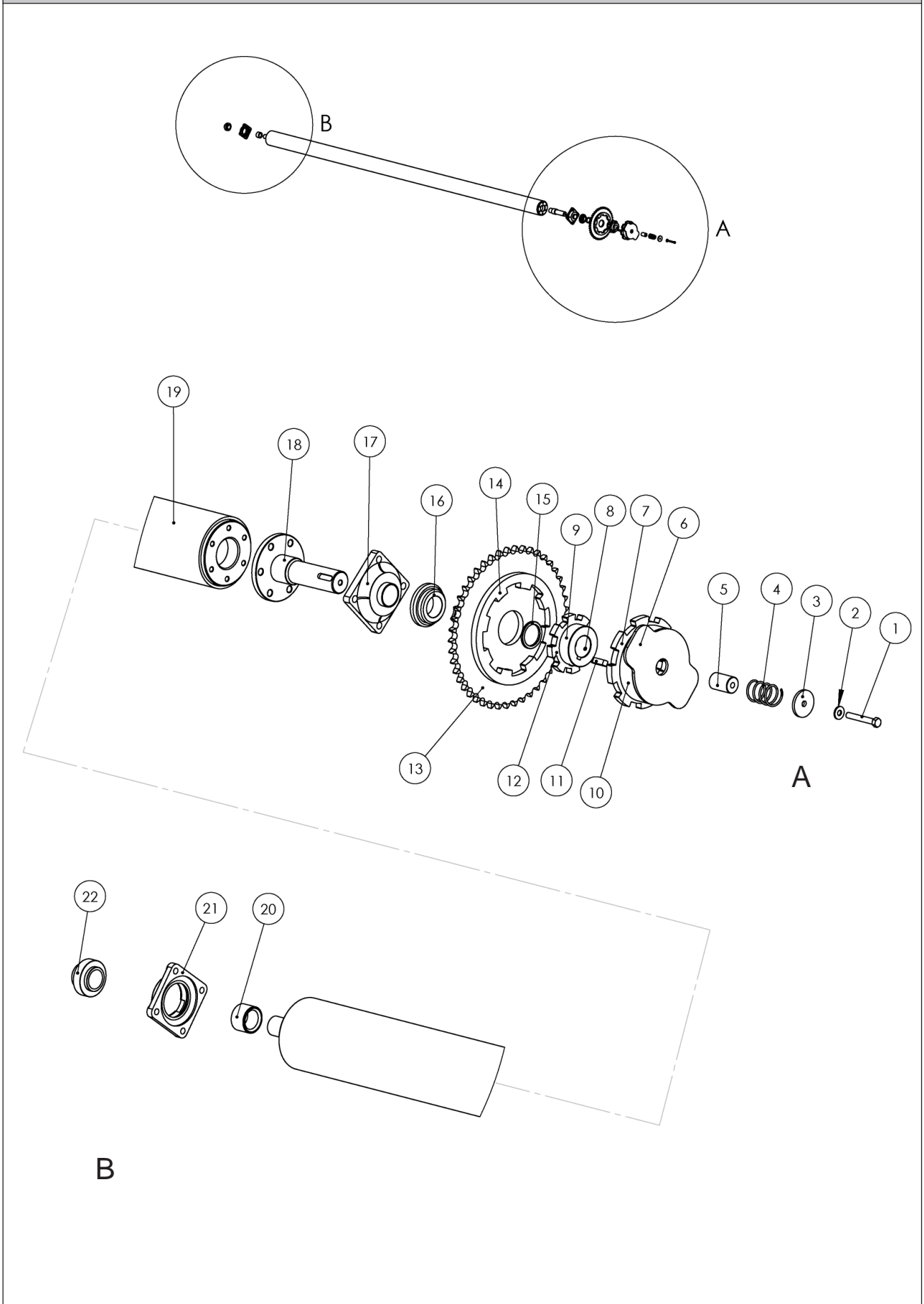

PARTS LIST # 3		PRIMARY VERTICAL AUGER	
#	PART NUMBER	NAME	QTY
1	27.42.87304	PRIMARY VERTICAL TUBE ASSEMBLY	1
2	27.39.87324	MALE COUPLING SHAFT ASSEMBLY	1
3	27.43.85332	LABYRINTH	1
4	27.39.87312	PRIMARY VERTICAL AUGER ASSEMBLY	1
5	25.39.80342	SUPPORT PLATE ASSEMBLY	1
6	98.755.355545	UC 209 BEARING	1
7	06.41.00245	AM-45 CAST IRON SUPPORT	1
8	27.39.85315	PENDULUM ASSEMBLY	1
9	98.300.300317	12-MM-THICK 1.1/4"NF JAM NUT	1

PRIMARY VERTICAL AUGER

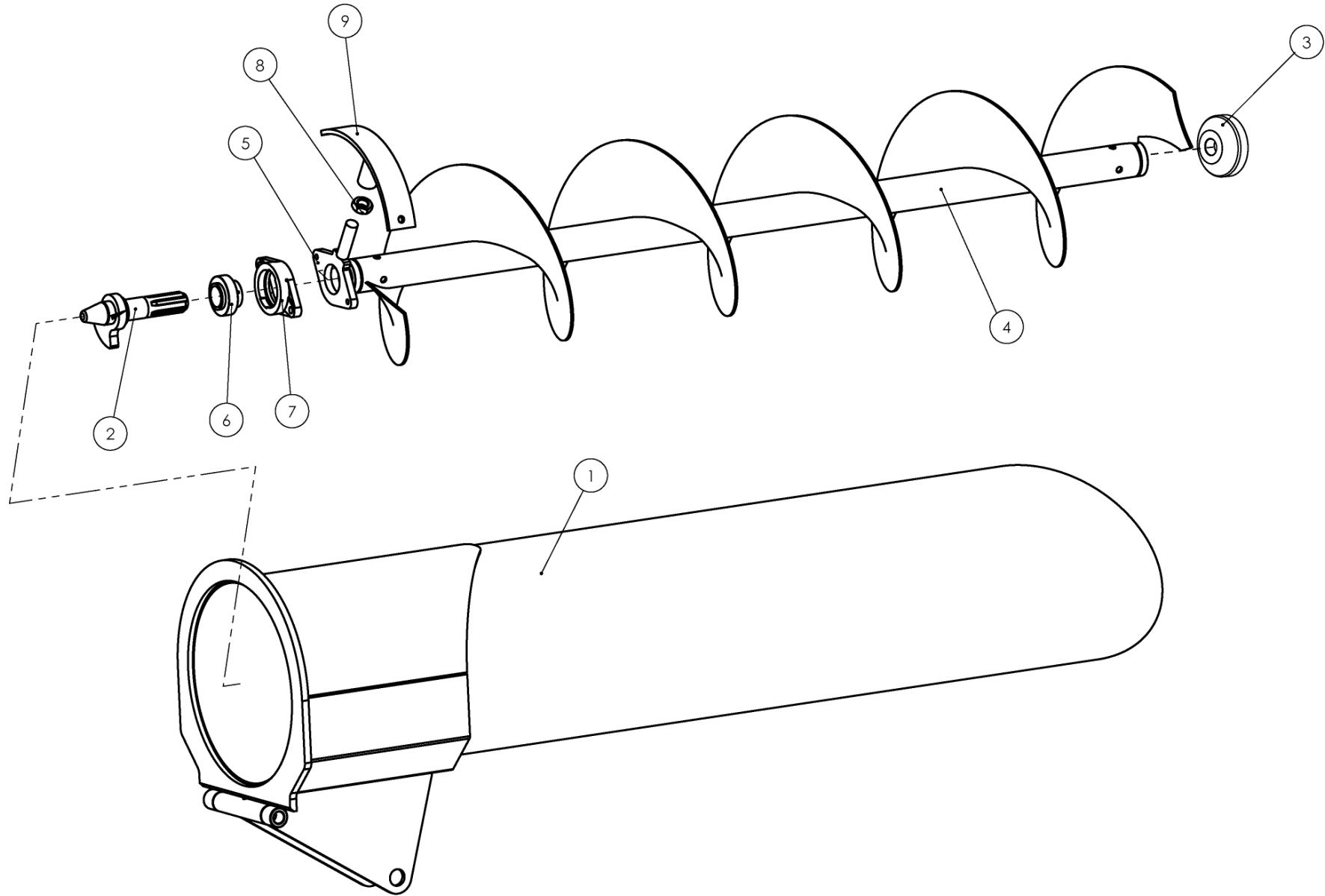

PARTS LIST # 4

SECONDARY VERTICAL AUGER

#	PART NUMBER	NAME	QTY
1	27.42.85317	SECONDARY VERTICAL TUBE ASSEMBLY	1
2	25.43.18306	HINGE PIN	1
3	27.42.87331	GRAIN CHANNEL	1
4	27.39.87318	SECONDARY VERTICAL AUGER ASSEMBLY	1
5	98.002.127165	G5 1/2" x 6 1/2" R W HEXAGONAL HEAD SCREW	4
6	27.42.85323	GRAIN CHANNEL	1
7	06.41.00145	AM-45 CAST IRON SUPPORT	1
8	98.755.355545	UC 209 BEARING	1
9	25.43.14405	AUGER END WASHER	1
10	98.310.100158	5/8" SPLIT LOCK WASHER	1
11	98.002.158032	G5 5/8" x 1 1/4" RW HEXAGONAL HEAD SCREW	1
12	98.342.014324	VERTICAL AUGER SPRING	4
13	98.301.150127	G5 1/2" HEXAGONAL NUT	8

PARTS LIST # 4

SECONDARY VERTICAL AUGER

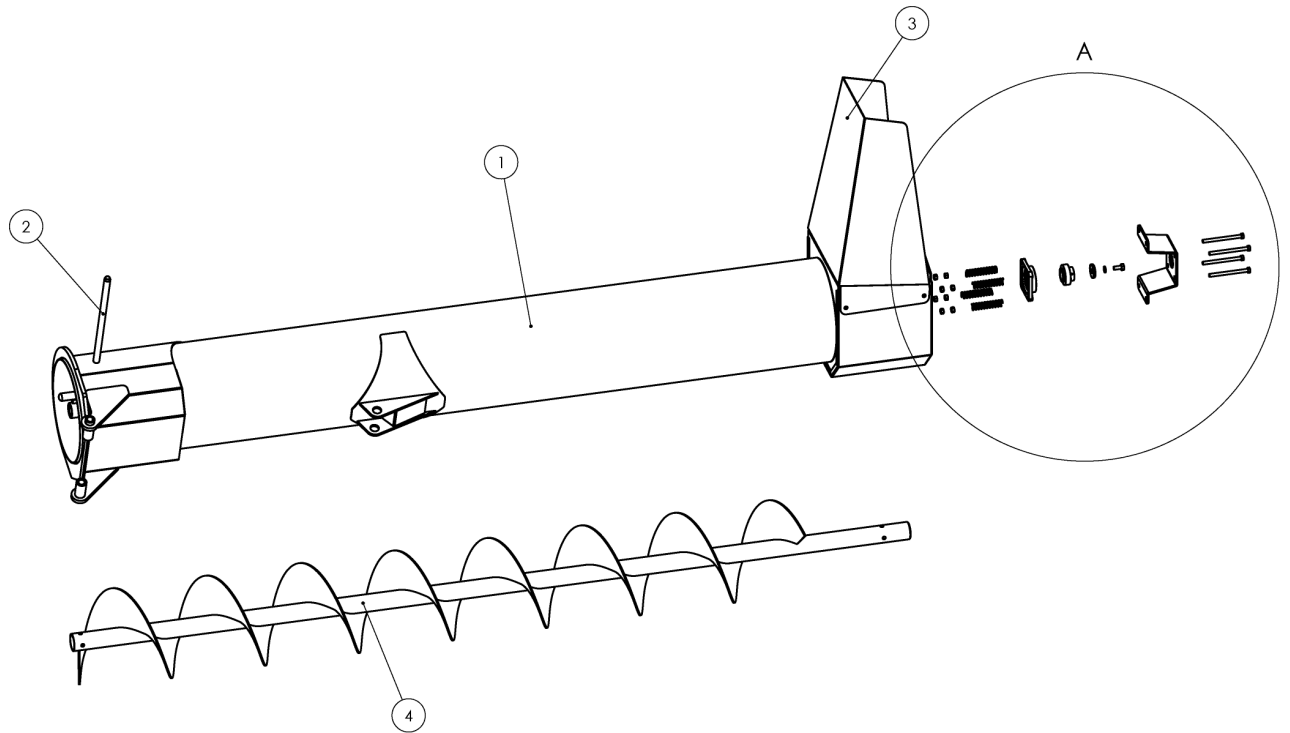

A

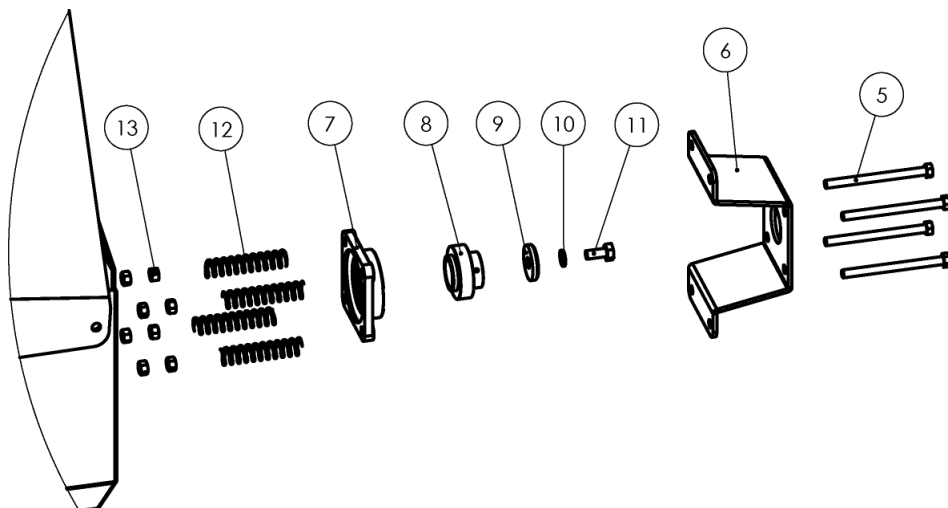

PARTS LIST # 5		MECHANICAL JACK - 27.29.85650	
#	PART NUMBER	NAME	QTY
1	27.29.85650	MECHANICAL JACK	1
2	27.39.14280	LONG PIN W/CHAIN	1

PARTS LIST # 5

MECHANICAL JACK - 27.29.85650

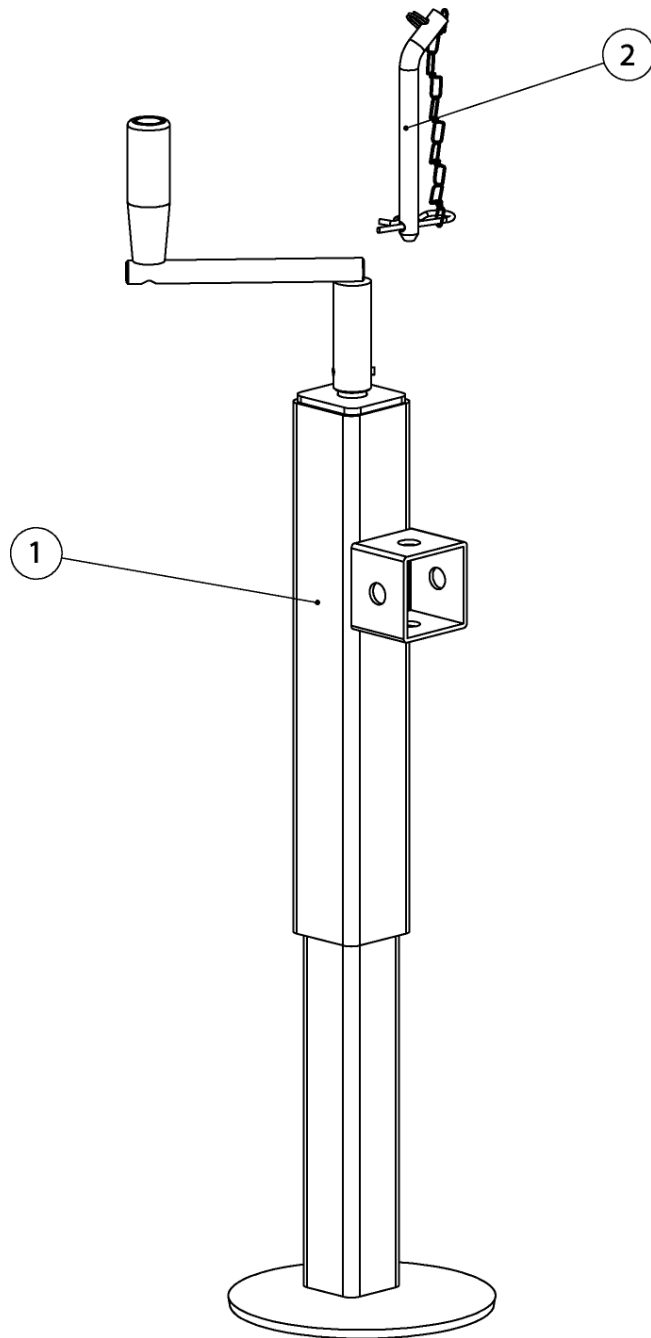

PARTS LIST # 6 DRIVE GEARBOX ASSEMBLY 20.29.87000

#	PART NUMBER	NAME	QTY
1	20.41.87002	BODY OF THE GEAR BOX LOWER PART	1
2	20.43.87015	CONE BEARING Z 16 – 32	1
3	20.41.87003	BODY OF THE GEAR BOX UPPER PART	1
4	20.41.87005	INLET HUB	1
5	98.370.100972	1/8" BSP BREATHING VALVE	1
6	20.43.87006	INLET SHAFT ADJUSTING NUT	1
7	20.42.09816	SEALING WASHER	1
8	20.43.87007	GEAR WHEEL Z 22	1
9	20.43.87008	INLET SHAFT (cotter 20.43.09813)	1
10	98.730.87009	30210 BEARING	2
11	98.611.276920	SAV 7529 - DBH 8956	1
12	98.730.330840	30208 BEARING	4
13	20.41.87010	SPLINED SHAFT END	1
14	98.730.132755	30211 BEARING	2
15	20.43.87011	Z6 - 1 3/4" SPLINED SHAFT (COTTER 20.43.87011)	1
16	20.43.87012	GEAR WHEEL Z 16 - 38	1
17	98.611.278380	SAV 10272	1
18	20.43.87013	ADJUSTING NUT	1
19	98.611.277670	SAV 6727	1
20	20.43.87016	COTTER 8X8X34	2
21	20.43.87014	Ø 40 SWEEPING AUGER SHAFT	1
22	20.43.09409	SEAL HOLDER	2
23	98.037.095019	SCREW UMBRACO WT 3/8"X3"	6
24	98.610.273940	SILICONE DBH-SAV 5300 SEAL	2
25	13.43.11051	3/8" BSPT PLUG	1
26	20.43.80024	1" BSPT HEXAGONAL-HEAD PLUG	1

PARTS LIST # 6

DRIVE GEARBOX ASSEMBLY

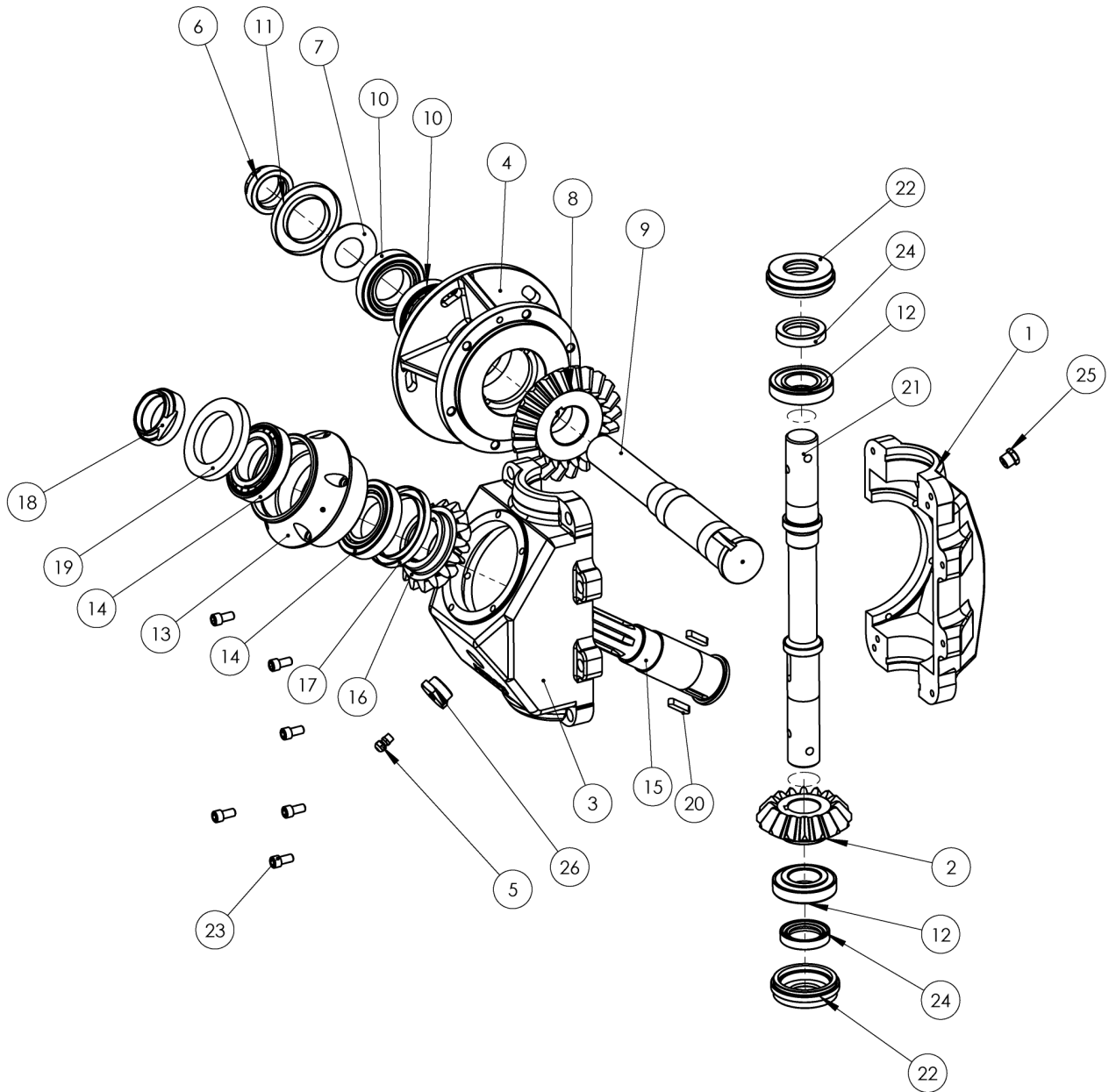

TECHNICAL DATA

- Oil type: SAE 90
- Oil volume: 2,5 litres

PARTS LIST # 7		REDUCTION GEARBOX - 20.29.85030	
#	PART NUMBER	NAME	QTY
1	20.41.85087	TOP COVER	1
2	20.41.85086	LOWER COVER	1
3	20.43.85081	GEAR WHEEL Z84 M3	1
4	20.43.85071	# 2 SHAFT	1
5	20.43.85072	SHORT INTERMEDIATE BUSHING	2
6	20.43.85082	GEAR WHEEL Z23 M3.5	1
7	20.43.85073	LONG INTERMEDIATE BUSHING	2
8	98.705.206530	6206 2RS BEARING	4
9	20.43.85074	NUMBER 2 STOP END	4
10	20.43.85091	GEAR WHEEL Z76 M3.5	1
11	20.43.85092	NUMBER 4 STOP END	1
12	20.43.85093	# 3 SHAFT	1
13	98.705.207750	6210-2RS BEARING	2
14	20.43.85094	LONG STOP END OUTLET BUSHING	1
15	20.43.85095	WASHER	1
16	20.43.85069	10X10X22 KEY	2
17	20.43.85096	NUMBER 3 STOP END	1
18	98.378.080568	"SAUER DANF HIDRAULIC MOTOR .	1
19	98.368.102120	M12 LIFTING EYEBOLT	1
20	98.310.100095	5/8" SPLIT LOCK WASHER	8
21	98.037.095089	RW 3/8" X 3.1/2" HEXAGONAL-SOCKET HEAD CAP SCREW	8
22	20.43.80024	1" BSPT HEXAGONAL-HEAD PLUG	1
23	98.370.100972	1/8" BSPT BREATHING VALVE	1
24	98.329.080018	8MM X18MM SPRING PIN	2
25	13.43.11051	3/8" BSPT PLUG	1
26	25.43.85075	STOP WASHER	1
27	25.43.85046	SEALING WASHER	1
28	20.43.85098	STOP WASHER	1
29	20.43.85042	NUMBER 1 GEAR WHEEL Z: 20 - M 2.5 (MOTOR)	1
30	98.007.080025	M 8x1.25 x 25 HEX.-HEAD SCREW	1
31	20.43.85477	10X10X50 KEY	1
32	20.43.85077	NUMBER 2 GEAR WHEEL Z80	1
33	20.43.85076	NUMBER 3 GEAR WHEEL Z21 M 3	1
34	20.43.85083	SPACER BUSHING	1
35	98.611.275568	DBH 8584 SEAL	1
36	98.310.100063	1/4" SPLIT LOCK WASHER	1
37	20.43.85097	WASHER	1

REDUCTION GEARBOX

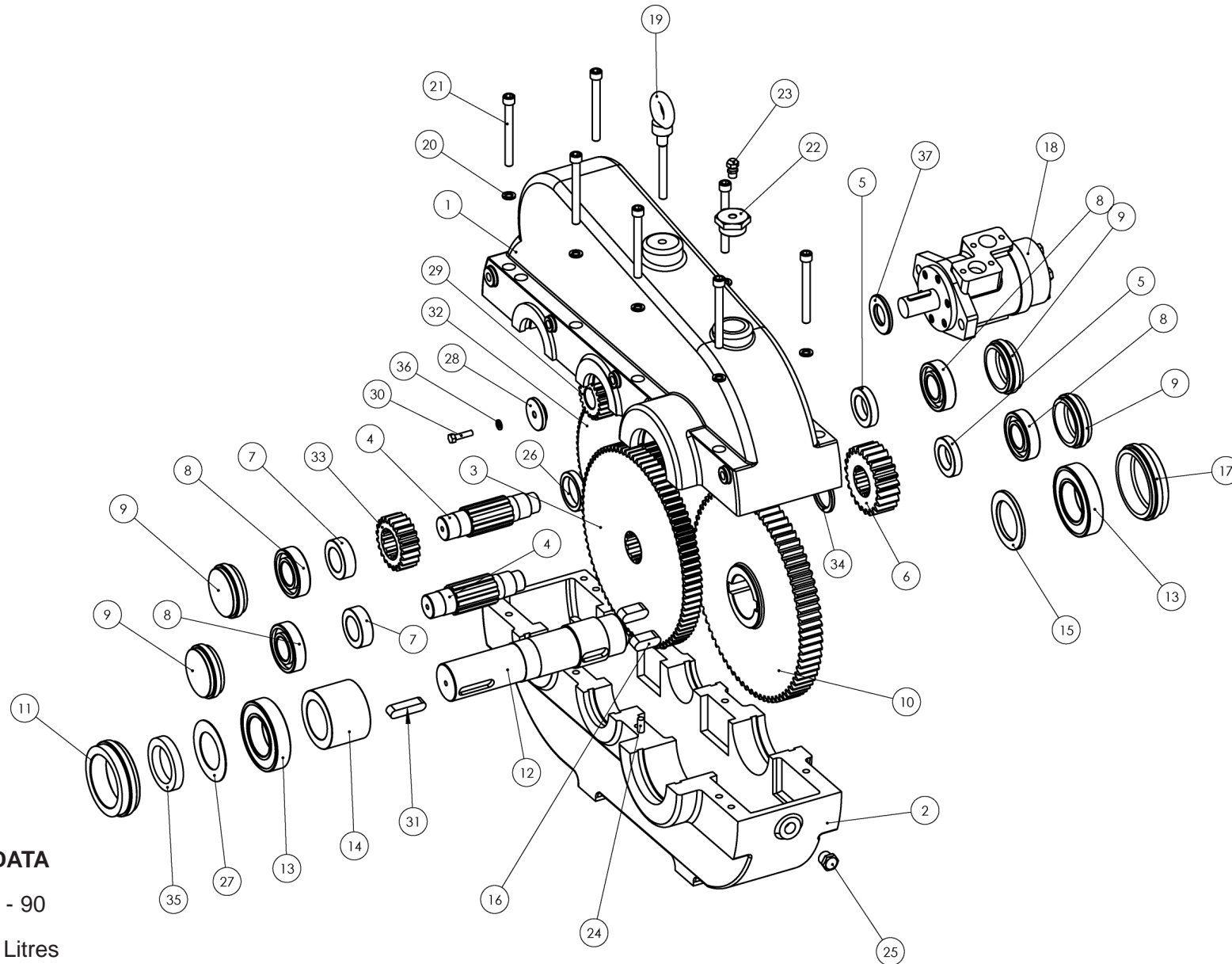

TECHNICAL DATA

- Oil type: SAE - 90
- Oil volume: 4 Litres

PARTS LIST # 8**LOAD SPEED-UP PUSHER- 27.29.87900**

#	PART NUMBER	NAME	QTY
1	98.378.082766	HYDRAULIC CYLINDER	1
2	27.43.81763	UPPER LOCK PIN	1
3	27.43.81764	LOWER LOCK PIN	1

LOAD SPEED-UP PUSHER

PARTS LIST # 8

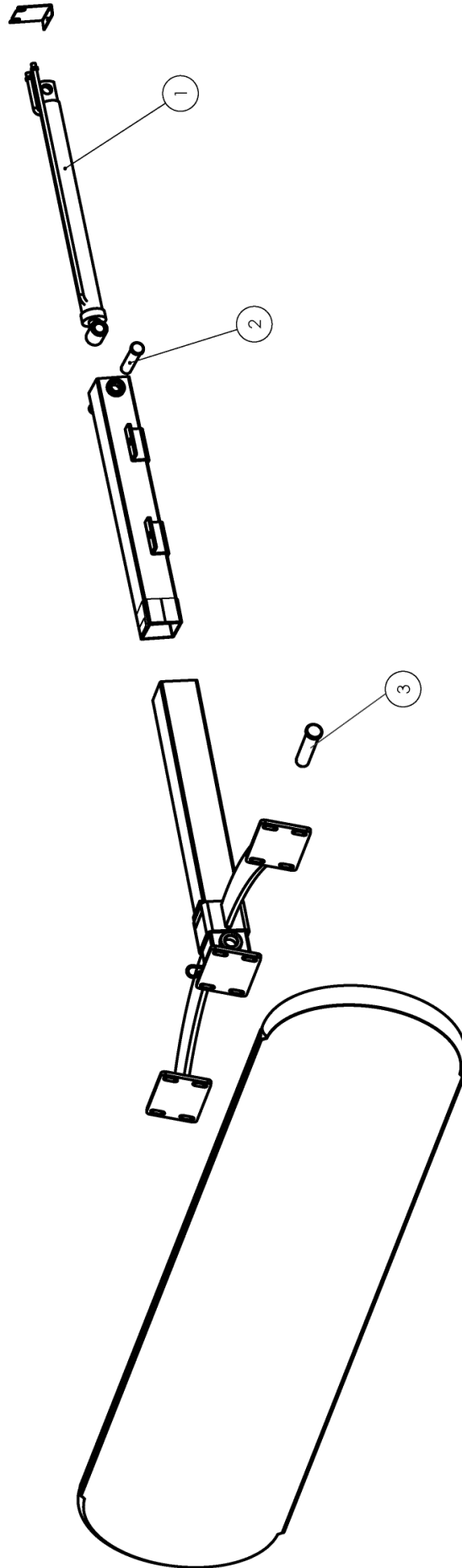

PARTS LIST # 9

EXG 300 HYDRAULIC SET UP

#	PART NUMBER	NAME	QTY
1	98.378.025306	Ø 3" X 600 MM HYDRAULIC CYLINDER	1
2	98.378.085774	Ø 4" X 200 MM HYDRAULIC CYLINDER	1
3	98.378.087923	Ø 2" X 500 MM HYDRAULIC CYLINDER	1
4	98.378.003162	80 CC ORBITAL HYDRAULIC MOTOR	1
5	98.378.085558	FLOW CONTROL VALVE 0 – 100 – W/ KNOB	1
6	98.378.087753	3 / 4 UNIDIRECTIONAL VALVE	1
7	98.378.087752	DIRECCIONAL CONTROL VALVE	1
8	98.378.087751	HOSES AND ACCESSORIES KIT 8700	1

9-a Detailed Components:

#	QTY	PART NUMBER	NAME
1	1	748-8-8	1.FLOW CONTROL VALVE ADAPTOR (I)
2	1	948-12-10	1.FLOW CONTROL INLET ELBOW (E)
3	1	748-10-10	1.FLOW CONTROL VALVE RETURN LINE ADAPTOR (II)
4	1	1454-10-10-10	1.RETURN LINE CDS60 TEE FITTING + FLOW CONTROL
5	1	INLET PRESSURE HOSE	HOSE LENGTH: 7400 ¾ R2 AT
5A	1	312-8-12	½ NPT MALE FIXED FITTING - ¾ HOSE
5B	1	NT-352-12-12	90° HG 1 3/6 JIC 37 UNF HOSE FITTING - ¾ HOSE
5C	1	PNH 1/2	QUICK CONNECT FITTING WITH TIP
5D	1	BTHP 1/2	INJECTED PLASTIC FEMALE PLUG
6	1	CDS 60 PRESSURE HOSE	HOSE LENGTH: 500 ½ R2 AT
6A	1	352-8-8	HG 7/8 JIC 37 HOSE FITTING
6B	1	352-8-8	HG 7/8 JIC 37 HOSE FITTING
7	1	748-8-8	CDS 60 INLET ADAPTOR
8	4	748-4-8	LIFT CYLINDER BODY ADAPTOR, LIFT CYLINDER BODY
9	2	748-8-8	MOTOR BODY ADAPTOR, CDS 60 RETURN LINE
10	1	948-9-9	RETURN LINE CDS620
11	2	UBE CYLINDER HOSE	¼" R2 AT HOSE LENGTH: 3500 mm
11A	2	C NT 352-6-4	HG 7/8 JIC 37 UNF HOSE FITTING – ½ HOSE
11 B	2	352-4-4	HG 9/16 JIC 37 HOSE FITTING- 1/4 HOSE
12	1	741-6-4 RESTRICTED COUPLING	TUBE CYLINDER RESTRICTED COUPLING
13	1	741-6-4-L.P	TUBE CYLINDER RESTRICTED COUPLING
14	2	MOTOR HOSE	½ R2 AT HOSE LENGTH: 3650
14A	4	352-8-8	HG 7/8 JIC 37 HOSE FITTING
15	1	941-8-8	MOTOR ELBOW
16	1	L-941-8-8	MOTOR ELBOW
17	1	LIFT CYLINDER HOSE	3/8 R2 AT HOSE LENGTH: 1000
17A	2	NT-352-4-6	90° HG 9/16 JIC 37 HOSE FITTING – 3/8 HOSE
17 B	1	352-6-6	3/4 JIC HOSE FITTING- 3/8 HOSE
18	1	LIFT CYLINDER HOSE	3/8 R2 AT HOSE LENGTH: 1300
18A	1	NT-352-4-6	90° HG 9/16 JIC 37 HOSE FITTING – 3/8 HOSE
18B	1	352-6-6	3/4 JIC HOSE FITTING- 3/8 HOSE
19	2	941-6-8	CODO 90° 3/4 JIC A ROSCA 1/5 NPT
20	1	CDS 60 RETURN LINE HOSE	¾" R1 AT HOSE LENGTH: 440
20A	1	352-8-12	HG 7/8 JIC UNF HOSE FITTING – ¾ HOSE
20B	1	351-10-12	HG 1-1/16 JIC UNF – ¾ HOSE
21	1	RETURN LINE HOSE TO TRACTOR	¾" R1 AT HOSE LENGTH: 4600 (BEFORE THE UNIDIRECTIONAL)
21A	1	351.10-12	HG 1-1/16 JIC UNF HOSE FITTING – ¾ HOSE
21B	1	311-12-12	¾ NPT MALE FIXED FITTING - ¾ HOSE
22	1	RETURN LINE HOSE TO TRACTOR	¾" R1 AT HOSE LENGTH: 4600 (AFTER THE UNIDIRECTIONAL)
22A	1	311-12-12	¾ NPT MALE FIXED FITTING - ¾ HOSE
22B	1	311-8-12	1/2 NPT MALE FIXED FITTING - ¾ HOSE
22C	1	PNH 1/2	QUICK CONNECT FITTING WITH TIP
22D	1	BTHP 1/2	INJECTED PLASTIC FEMALE PLUG
23	2	PUSHING CYLINDER HOSE	¾" R1 AT HOSE LENGTH: 1250MM
23A	2	352-4-4	9/16 JIC HOSE FITTING- 1/4 HOSE
24	2	748-4-8	9/16 JIC ADAPTOR - 7/8 ORING

EXG 300 HYDRAULIC SET UP

PARTS LIST # 9

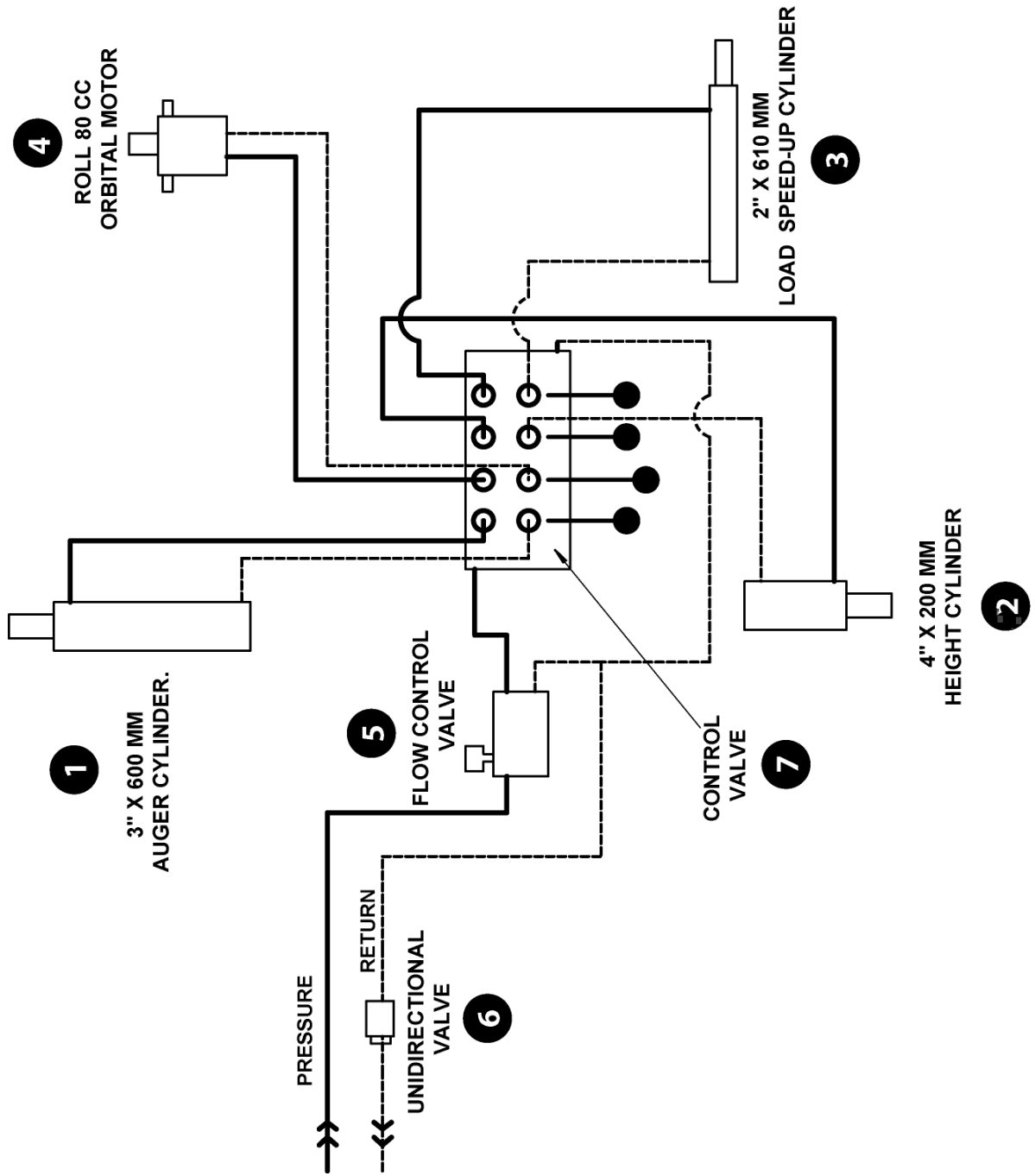

14. PARTS SUBJECT TO NORMAL WEAR AND TEAR:

Ordinary maintenance and spare parts replacement services of the parts detailed below are the equipment owner's exclusive responsibility, therefore, they will not be considered defects in material or manufacturing, but rather defects due to normal wear and tear; improper operation or insufficient equipment maintenance.

- Chains
- Augers
- Bearings
- Articulation Bushings
- Oil
- Wheels
- Sprockets
- Brake System (brake pad ; shoe linings)
- Wear due to grain friction

Parts subject to improper operation or insufficient maintenance.

Using the gearboxes without normal oil level or not complying with the transmission inlet specifications described in the user's manual.

Altering the maximum inlet torque (shear bolt system on PTO).

MACHINE	MAXIMUM ALLOWED INLET TORQUE	PROBABLE CAUSES THAT CAN ALTER THE MAXIMUM ALLOWED TORQUE
E 180 Unloader EXG 300 Unloader E 9250 FH Bagger E 9250 D Bagger MAX 14 / 20 / 22 / 24 / 6,5 / 8,5 Grain Carts	1860 N/m	Replacing the PTO's shear pin with a different bolt specification. Using a PTO that exceeds the maximum torque allowed by the machine.
MAX 28 / 25 Grain Cart	2130N/m	Replacing the PTO with a PTO with no shear pin device installed.
Vertical MIXER MXR 14	1600 N/m	

Wheel nuts: After around 50 hours of running, wheel nuts must be retighten according to the torque values detailed in the manual 9kgm =90 Nm = 65 lbs. pie - point 7.f.

Special care should be taken to the wheel nuts tightening if the machine has moved over paths or roads. Failure to follow these instructions may cause rim damage or lost of it.

AKRON

Rosario de Santa Fe 2256 - X2400EFN San Francisco CBA

Tel./Fax: + 54 3564 - 435900 - Línea Gratuita: 0 800 333 8300

e-mail: export@akron.com.ar - www.akron.com.ar